



Erasmus+

This project is funded by the European Union.

**Modernization of the
Curricula in sphere of
smart building
engineering - Green
Building (GREB)**

**ADVANCED ENERGY
CONVERSION SYSTEMS**

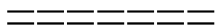

**ЗАМОНАВИЙ ЭНЕРГИЯ ЎЗГАРТИРИШ
ТИЗИМЛАРИ**

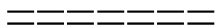

**СОВРЕМЕННЫЕ ЭНЕРГИЯ
ПРЕОБРАЗУЮЩИЕ СИСТЕМЫ**



Tahkent - 2018

The publication is made on the basis of materials of the international project «Modernization of the Curricula in sphere of smart building engineering - Green Building (GREB)» 574049-EPP-1-2016-1-IT-EPPKA2-CBHE-JP and in the framework of the Erasmus+ program.

Suffice it to recall that renewable and resource-saving technologies for obtaining electricity are becoming cheaper year by year, while traditional ones, due to their remoteness from industrial and transport facilities, are becoming more expensive every year.

In addition, in our country, most of which are located in the high-latitude zone, it is necessary to conscientiously consume non-renewable sources (oil, gas, coal, etc.) that are necessary for future generations to operate mobile vehicles.

Considering the importance of this problem in the current conditions of transport development, the specialists of the scientific research institutes and higher educational institutions of railway transport developed a program for resource saving, which was the stimulating factor for the preparation of this manual.

This project has been funded with support from the European Commission. This publication reflects the views only of the authors, and the Commission cannot be held responsible for any use which may be made of the information contained therein.

Authors: I.X. Siddikov, Kh.A. Sattarov, O.I. Siddikov, X.E. KHujamatov, D.T. KHasanov, Sh.B. Olimova

© Tashkent University of Information Technologies

ТАШКЕНТ 2018

CONTENT:

I. INTRODUCTION	9
II. MATERIAL THEORETICAL ACTIVITIES	13
LECTURE 1. POWER SYSTEMS.	13
Features of power supply for devices and base stations of local branches of communication. ..	13
Theoretical basis for the use of renewable energy sources.	17
LECTURE 2. VALUES CHARACTERIZING ELECTRIC ENERGY.....	22
The quantities characterizing the electrical energy	22
Basic laws of electrical engineering.....	29
LECTURE 3. SOURCES OF ELECTRICITY. ...	43
Primary and secondary sources of energy supply	53
LECTURE 4. TYPES OF ELECTRIC POWER SOURCES.	60

Traditional and non-traditional energy sources.	60
Classification of renewable energy sources.	69
Wind energy	72
Energy of the ebb and flow.....	81
Energy waves.	82
Geothermal energy	83
Bioenergetics.....	84
Biofuel of the first generation.....	84
Second generation biofuels.....	85
Biofuel of the third generation.....	86
LECTURE 5. WIND ENERGY AND HYDROPOWER.....	88
Wind power conversion devices. Possibilities of using and implementing wind turbines	88
Brief classification of wind power plants.....	92
Schematics and Elements of Wind Power Production	98
Limit wind power and ways to improve reliability	100

LECTURE 6. SOLAR ENERGY.	102
Polycrystalline and single-crystal energy converters.....	104
Photodetectors. Photocells with internal and external photoelectric effect	108
The principle of the photocell.....	117
Regulated limits of converted solar energy....	122
Features of an electrical circuit containing a solar photocell.....	123
LECTURE 7. ELECTRICAL NETWORKS AND SYSTEMS	126
Electrical networks and systems	126
Electric stations and substations	133
Power Transmission and Distribution Devices	141
LECTURE 8. METHODS OF REDUCING THE LOSS OF ELECTRIC ENERGY.	148
Methods for reducing the loss of electrical energy	148

Devices of intellectual control.....	155
Technology of SmartGrid networks and intelligent devices.....	157
LECTURE 9. CONVERSION OF ELECTRIC ENERGY	168
Conversion of electrical energy	168
Transformer idling.....	175
Transformer operating mode.	179
Transformer short-circuit.....	181
LECTURE 10. RECTIFIERS.....	183
Structural diagram of the rectifier.....	183
Gates and their parameters	185
Single-phase single-cycle rectification scheme	188
Bridge rectification scheme	190
Two-cycle rectification scheme with zero output of the secondary circuit of the transformer	192
LECTURE 11. SMOOTHING FILTERS. MULTIPLE VOLTAGES.	195

Filters	195
Passive filters	198
Single-section L-shaped LC filter	203
Single-section Π -shaped LC filter	205
Active Filters.....	206
Voltage Multipliers	209
LECTURE 12. STABILIZERS	215
Voltage and current stabilizers	215
Parametric Voltage Regulator.....	216
Compensating voltage regulators.....	223
LECTURE 13. CONVERTERS	230
Voltage converters.....	230
Push-pull converters with independent excitation	234
Thyristor converters	239
LECTURE 14. SOURCES OF UNINTERRUPTED FEED	244
Main Types of UPS	244
UPS type Stand-By.....	244

UPS type Line-Interactive	245
UPS type On-Line	247
UPS Functions.....	248
Main specifications of uninterruptible power supplies	250
Selecting an uninterruptible power supply	256
LECTURE 15. SYSTEMS OF ACCOUNTING AND CONTROL OF ENERGY CONSUMPTION (ASKUE)	258
Modern integrated systems for monitoring and accounting of electricity	258
The concept of AMR.....	264
Commercial and technical AMR	267
Glossary	272
Basic reference.....	278

I. INTRODUCTION

At the turn of the 21st century, mankind faced a serious problem concerning not only the production of energy from nonrenewable sources (coal, oil, gas, etc.) from the point of view of the economy, but also with serious environmental difficulties that violate the dynamic balance in nature. It is now clear that the widespread use of non-renewable energy sources leads to negative processes: to the growth of thermal, chemical and radioactive contamination of the environment, which violates the natural habitat of man.

Of course, there is still hope for the production of energy through thermonuclear reactors. But at the present time this possibility can not be practically realized because of the absence of even demonstration thermonuclear reactors. Meanwhile, experts are only discussing the international project of the ITER thermonuclear reactor. In addition, fusion reactors are

not completely devoid of radioactive waste. And the problem of processing and burial of such wastes has not been finally solved.

Therefore, mankind had to turn to renewable and resource-saving technologies for generating electricity. It is solar, hydropower, wind power and some other kinds. Even active participants in the outstripping development of nuclear power in their forecasts for the middle of the 21st century assume that with the help of renewable sources, 18-20% of energy will be produced, and according to some estimates even up to 40%.

Renewable and resource-saving sources bribe their relative ecological purity. In addition, these sources, as a rule, have a long service life of 20-30 years [4, 5]. Renewable energy, like any other, has certain limitations for this particular region. In order for the use and use of renewable and resource-saving energy to reach the required level, it is necessary to

turn in our notions about these sources, create the preconditions for the introduction of devices operating from these sources in society, train highly qualified specialists who could not only develop such devices, but also competently to conduct their operation.

Equally important is the economic factor. Suffice it to recall that renewable and resource-saving technologies for obtaining electricity are becoming cheaper year by year, while traditional ones, due to their remoteness from industrial and transport facilities, are becoming more expensive every year. In addition, in our country, most of which are located in the high-latitude zone, it is necessary to conscientiously consume non-renewable sources (oil, gas, coal, etc.) that are necessary for future generations to operate mobile vehicles.

Considering the importance of this problem in the current conditions of transport development, the specialists of the scientific research institutes and

higher educational institutions of railway transport developed a program for resource saving, which was the stimulating factor for the preparation of this manual.

II. MATERIAL THEORETICAL ACTIVITIES

LECTURE 1. POWER SYSTEMS.

Lecture plan:

1.1. Power supply features.

1.2. Theoretical foundations for the use of renewable energy sources

Features of power supply for devices and base stations of local branches of communication.

All energy sources can be divided into two types - renewable and non-renewable, or, as they are called, exhaustible.

Renewable sources of energy are sources based on constantly existing or periodically occurring energy flows in the environment. Renewable energy is not a consequence of a person's purposeful activity, and this is its distinguishing feature.

Non-renewable energy sources are natural reserves of substances and materials that can be used by man for energy production. Examples include nuclear fuel, coal, oil, gas. The energy of non-renewable sources, unlike renewable sources, is in nature in a related state and is released as a result of purposeful human actions. In accordance with the UN General Assembly resolution No. 33/148 (1978), non-traditional and renewable sources of energy include: solar, wind, geothermal, sea waves, tidal and ocean energy, biomass, wood, charcoal, peat, draft animals, shale, bituminous sandstones and hydropower of large and small watercourses.

Potential opportunities of non-traditional and renewable energy sources are, billion tce per year:

- The energy of the Sun - 2300;
- wind power - 26.7;
- biomass energy - 10;
- heat of the Earth - 40,000;

- energy of small rivers - 360;
- the energy of the seas and oceans - 30;
- energy of secondary low-potential heat sources - 530.

Of the listed sources, the first three are renewable, and the 4th and 5th are depleted.

Let's give the basic concepts concerning renewable energy sources.

The resource (potential) of a renewable energy source is the amount of energy that is concluded or recovered under certain conditions from a renewable energy source during the year. The gross potential of a renewable energy source is the average annual volume of energy contained in a given renewable energy source when it is converted into useful energy. The technical potential of renewable energy is a part of the gross potential, the transformation of which into useful energy is possible at a given level of

technological development, while respecting the requirements for environmental protection.

The economic potential of renewable energy is a part of the technical potential, the transformation of which into economically useful energy is economically feasible at a given level of prices for fossil fuels, thermal and electric energy, equipment, materials and transport services, wages, etc. Consider the most universal sources of released energy: solar and wind, hydropower, tidal energy, wave energy.

The strategic goals of using renewable energy sources and local fuels are:

- reduction of consumption of non-renewable fuel and energy resources;
- reduction of the ecological load from the fuel and energy complex;
- provision of decentralized consumers and regions with long-distance and seasonal delivery of fuel;

- reduction of costs for long-range fuel.

The need for the development of renewable energy is determined by its role in solving the following problems:

- ensuring sustainable heat and electricity supply to the population and production in the areas of decentralized energy supply.

- Ensuring a guaranteed minimum of energy supply to the population and production in the areas of centralized energy supply, experiencing energy shortages, preventing damage from emergency and limiting outages;

- Reduction of harmful emissions from power plants in cities and settlements with a complex environmental situation, as well as in places of mass recreation of the population.

Theoretical basis for the use of renewable energy sources.

Experience shows that before developing energy on renewable sources, it is necessary to accurately determine their power. Of course, this requires long and regular observations and analysis of the parameters of these sources. The time characteristics of renewable sources are of great importance. In Table. 2 presents the main parameters that determine the power of various sources, and the characteristic periods of its changes, which can vary greatly depending on specific local conditions.

The intensity of renewable energy Source
 Periodicity Determining Parameters Note Direct
 sunlight 24 h, a year Irradiation (W / m^2), angle of
 incidence of radiation Only daytime Dissipated solar
 radiation 24 h, 1 year Cloudiness However, the energy
 is significant Biofuel 1 year Soil quality, irradiation,
 water, fuel specificity, costs Very many types of fuel.
 Sources: forestry and agriculture Wind a year Wind

speed, height above the earth surface Fluctuates $b = 0.15$

Waves a year Amplitude of wave H and its period T High energy density ($\sim 50 \text{ kW} / \text{m}$) Hydroelectricity a year Head H , volume flow of water Q Artificially created source Source Periodicity Determining parameters Note Tides 12 hours 25 min Tide height R , basin area A , length of estuary L , depth of estuary h Increase in tide if it is $36400 \text{ m}^{0.5}$ Thermal energy Constant parameters Difference in water temperature at surface and at depth A number of areas in the tropics. Low energy efficiency of energy conversion

Often talk about the quality of the source of energy. We will understand by the quality of energy the fraction of the source energy that can be converted into mechanical energy. Proceeding from this, renewable sources can be divided into three groups.

1. Sources of mechanical energy, for example, hydrowaves, wave and tidal. The energy quality of these sources is high, and they are usually used to generate electricity. The quality of wave and tidal energy is estimated at 75%, hydropower - 60%, wind energy - about 30%.

2. Thermal renewable energy sources are, for example, biofuel and solar thermal energy. The maximum fraction that can be used to obtain mechanical work is determined by the second law of thermodynamics. However, in practice, about 50% of the heat can be converted into work permitted by the second law of thermodynamics. For modern steam turbines, the quality of thermal energy does not exceed 35%

3. Energy sources based on photonic processes, using photosynthesis and photoelectronic phenomena. In practice, the efficiency of photo-converters, equal

to 15%, is considered good.

LECTURE 2. VALUES CHARACTERIZING ELECTRIC ENERGY.

Lecture plan:

2.1. The quantities characterizing the electrical energy. The units of measurement.

2.2. Basic laws of electrical engineering.

2.3. Single-phase and 3-phase networks.

The quantities characterizing the electrical energy

Electric current (I) is the directed movement of electrical charges (ions in electrolytes, conduction electrons in metals). A necessary condition for the flow of electric current is the closure of the electrical circuit.

The electric current is measured in amperes (A).

Derived current measurement units are:

1 kiloampere (kA) = 1000 A;

1 milliampere (mA) 0.001 A;

1 microampere (μ A) = 0.000001 A.

A person begins to feel a current passing through his body in 0.005 A. Current greater than 0.05 A is dangerous for human life.

The electric voltage (U) is the potential difference between two points of the electric field. Voltage (voltage drop) is a quantitative measure of the potential difference (electrical energy) between two points of an electrical circuit. The voltage of the current source is the potential difference at the terminals of the current source. The voltage is measured with a voltmeter.

The unit of measure is Volt (V). The voltage is indicated by the letter -U, the voltage of the power source (synonym - electromotive force) can be indicated by the letter -E.

The unit of the electrical potential is the voltage (V).

$$1\text{V} = (1\text{ W}): (1\text{ A}).$$

Derivative units of voltage measurement are:

1 kilovolt (kV) = 1000 V;

1 millivolt (mV) = 0.001 V;

1 microvolt (μ V) = 0.000001 V.

The resistance of a section of an electrical circuit is a quantity that depends on the material of the conductor, its length and cross-section. The resistance is measured by the device called the Ohmmeter. The electrical resistance is measured in ohms (Ohms). $1 \Omega = (1 \text{ V}) : (1 \text{ A})$. The resistance is indicated by the letter -R. It is connected with the current and voltage by Ohm's law (formula):

$$R = \frac{U}{I}$$

where U is the voltage drop across the element of the electrical circuit, I is the current flowing through the circuit element.

Derived resistance units are:

1 kilohm ($k\Omega$) = 1000 ohms;

1 megaohm ($M\Omega$) = 1 000 000 Ohm;

1 million Ohm (mOhm) = 0.001 Ohm;

1 micro Ohm ($\mu\Omega$) = 0.00000 1 Ohm.

The electrical resistance of the human body, depending on a number of conditions, ranges from 2000 to 10 000 ohms.

The specific electrical resistance (ρ) is the resistance of a wire 1 m long and 1 mm² cross section at a temperature of 200 ° C. The reciprocal of the resistivity is called the specific electric conductivity (γ).

The power (P) is a quantity characterizing the speed at which the energy conversion takes place, or the speed at which work is performed. The power of the generator is a quantity characterizing the rate at which a mechanical or other energy is converted into an electric energy in the generator.

The power of the consumer is a quantity that characterizes the speed with which the conversion of electrical energy in certain parts of the chain occurs to other useful types of energy.

Power is determined by the dependence:

$$P = I \times U$$

The system unit of power in SI is watt (W). It is equal to the power at which work is performed in 1 joule for 1 second: $1\text{W} = 1\text{J} / 1\text{sec}$.

Derivative units for measuring electrical power are:

1 kilowatt (kW) = 1000 W;

1 megawatt (MW) = 1000 kW = 1 000 000 W;

1 milliwatt (mW) = 0.001 W;

1 horsepower (hp) = 736 W = 0.736 kW.

Units of measurement of electrical energy are:

1 watt-second (Ws) = 1 J = (1 N) (1 m);

1 kilowatt-hour (kWh) = 3,6 10⁶ watts.

Conductivity of the circuit element - the ability of the circuit element to conduct an electric current. The conductivity unit is Siemens (cm). The conductivity is denoted by σ . Conductivity is the

reciprocal of the resistance, and is related to it by the formula:

$$\sigma = I/R$$

The frequency of the electric current is a quantitative measure characterizing the rate of change in the direction of the electric current. There are concepts - circular (or cyclic) frequency - ω , which determines the rate of change of the phase vector of the electric (magnetic) field and the frequency of the electric current - f , characterizing the rate of change in the direction of electric current (times, or oscillations) per second. The frequency is measured by an instrument called a Frequency meter. The unit of measurement is Hertz (Hz). Both frequencies are connected with each other via the expression:

$$\omega = 2\pi f$$

The period of the electric current is the reciprocal of the frequency, indicating for how long the electric

current makes one cyclic oscillation. The period is measured, usually with an oscilloscope. The unit of the period is a second (s). The period of the electric current fluctuation is denoted by the letter -T. The period is related to the frequency of the electric current by the expression:

$$T = \frac{1}{f}$$

Electrical capacitance is a quantitative measure characterizing the ability to store the energy of an electric current in the form of an electric charge on the capacitor plates. The electrical capacitance is designated by the letter -C. The unit of electrical capacitance is Farad (F).

Magnetic inductance is a quantitative measure characterizing the ability to store the energy of an electric current in the magnetic field of an inductor (throttle). The magnetic inductance is designated by the letter -L. The unit of inductance is Henry (HH).

Name Denotation in Latin font Units of measurement

Name Voltage U, u Volt Electromotive force E, e
Volt Current I, i Ampere Resistance active R, r Ohm
Resistance reactive X, x Ohm Resistance total Z, z
Ohm Power Active P Volt Ampere Reactive power Q
reactive Full power S Volt Ampere Energy W Watt-
second or Joule

Basic laws of electrical engineering.

The basic law of electrical engineering, through which it is possible to study and calculate electrical circuits, is Ohm's law establishing the relationship between current, voltage and resistance. It is necessary to clearly understand its essence and be able to use it correctly when solving practical problems. Often in electrical engineering mistakes are made because of the inability to correctly apply Ohm's law. Ohm's law for the circuit section states that the current

is directly proportional to the voltage and is inversely proportional to the resistance.

If we increase the voltage acting in the electric circuit several times, then the current in this circuit will increase by the same factor. And if you increase the resistance of the circuit several times, then the current will decrease by the same amount. Similarly, the water flow in the tube is greater, the stronger the pressure and the less resistance the pipe exerts to the movement of water. To express Ohm's law mathematically the most simple, consider that the resistance of the conductor, in which 1 A current passes a current of 1 A, is 1 Ohm.

The current in amperes can always be determined by dividing the voltage in volts by the resistance in ohms. Therefore, the Ohm law for the chain section is described by the following formula:

$$I = U/R.$$

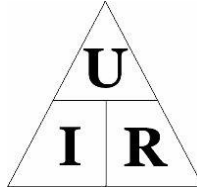

The Magic Triangle

Any section or element of an electrical circuit can be characterized by three characteristics: current, voltage and resistance. How to use the Ohm triangle: close the required value - two other symbols will give a formula for its calculation. By the way, Ohm's law calls only one formula from a triangle - one that reflects the dependence of the current on the voltage and resistance. Two other formulas, although they are its consequence, have no physical meaning.

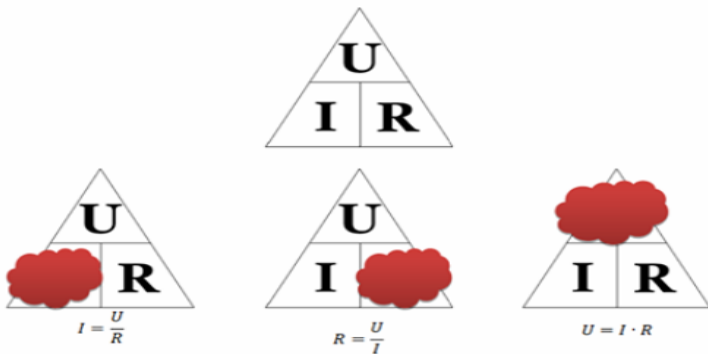

The calculations performed with Ohm's law for the circuit section will be correct when the voltage is expressed in volts, the resistance in ohms and the current in amperes. If multiple units of measurement of these quantities are used (for example, milliampere, millivolt, mega-ohm, etc.), then they should be transferred to amperes, volts and ohms, respectively. To emphasize this, sometimes the formula for Ohm's law for a chain section is written thus:

$$\text{ampere} = \text{volts} / \text{ohm}$$

It is also possible to calculate the current in milliamperes and micro amperes, with the voltage being expressed in volts, and the resistance in kilohms and megaohms, respectively.

The law of Joule-Lenz (after the English physicist JP Joule and the Russian physicist E.Kh.Lents) is a law characterizing the thermal action of an electric current.

Overcoming the resistance of the conductor, the electric current does the work, during which heat is generated in the conductor. Free electrons in their movement collide with atoms and molecules and in these collisions the mechanical energy of the moving electrons goes to the thermal one. The dependence of thermal energy on the current in the conductor is determined according to the Joule-Lenz law. When the electric current passes through the conductor, the amount of heat emitted by the current in the conductor is directly proportional to the current strength, taken in the second degree, the magnitude of the resistance of the conductor and the time of action of the current.

According to the law, the amount of heat Q (in joules) emitted in a conductor when a direct current flows through it depends on the current I (in amperes), the resistance of the conductor R (in ohms) and the time it passes t (in seconds): $Q = I^2Rt$. The conversion of electrical energy into heat is widely used in electric

furnaces and various electric heaters. The same effect in electric machines and apparatus leads to an involuntary expenditure of energy (loss of energy and a decrease in efficiency). Heat, causing the heating of these devices, limits their load. When overloaded, an increase in temperature can cause insulation damage or shorten the life of the unit.

The law of Kirchhoff (after the German physicist G.R. Kirchhoff (1824-1887)) - the two basic laws of electrical circuits. Kirchhoff's laws establish relations between currents and voltages in branched electrical circuits of arbitrary type. Kirchhoff's laws are of particular importance in electrical engineering because of their versatility, since they are suitable for solving any electrical problems. The first law Kirchhoff extends from the law of conservation of charge. It consists in the fact that the algebraic sum of the currents converging at any site is equal to zero.

$$\sum_{i=1}^n I_i = 0$$

where n is the number of currents converging at a given node. For example, for an electrical circuit node, the equation according to the first Kirchhoff law can be written in the form $I_1 - I_2 + I_3 - I_4 + I_5 = 0$

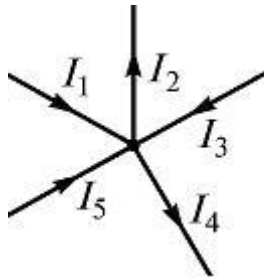

In this equation, currents directed toward the node are assumed positive. Kirchhoff's second law: the algebraic sum of the stress drops on individual sections of a closed contour arbitrarily selected in a complex branched chain is equal to the algebraic sum of the emf in this contour

$$\sum_{i=1}^k E_i = \sum_{i=1}^m I_i R_i$$

where k is the number of emf sources, m is the number of branches in a closed loop; I_i , R_i - current and resistance of the i -th branch.

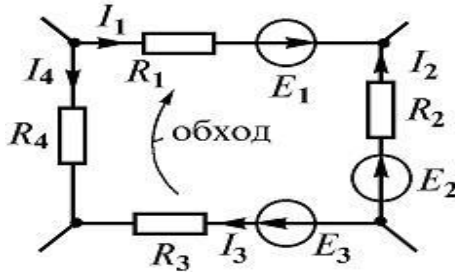

So, for a closed loop circuit (Fig. 2), $E_1 - E_2 + E_3 = I_1R_1 - I_2R_2 + I_3R_3 - I_4R_4$ A note on the signs of the resulting equation:

1) The EMF is positive if its direction coincides with the direction of an arbitrarily chosen contour traversal;

2) the voltage drop across the resistor is positive if the current direction in it is the same as the direction of the bypass.

The law of the complete current of the basic laws of the electromagnetic field. It establishes the relationship between the magnetic force and the

magnitude of the current passing through the surface. By total current is meant the algebraic sum of currents penetrating the surface bounded by a closed contour. The magnetizing force along the contour is equal to the total current passing through the surface bounded by this contour. In general, the field strength at different parts of the magnetic line can have different values, and then the magnetizing force will be equal to the sum of the magnetizing forces of each line. The Lenz law is the basic rule that encompasses all cases of electromagnetic induction and allows one to establish the direction of the emerging emf. induction.

According to Lenz's law, this direction in all cases is such that the current created by the emf that has arisen prevents the changes caused by the emf. induction. This law is a qualitative formulation of the law of conservation of energy in application to electromagnetic induction. The combustion products in the boiler of a power plant, while cooling, give up

their internal energy in the form of heat to water and water vapor. However, for technical and economic reasons, combustion products can not be cooled to ambient temperatures. They are ejected through the tube into the atmosphere at a temperature of about 400 K, taking with them a portion of the initial energy. Therefore, only 95% of the initial energy will pass into the internal energy of the water vapor.

The resulting water vapor will enter the steam turbine, where its internal energy will at first partially become the kinetic energy of the steam strings, which will then be given off as mechanical energy to the turbine rotor.

Only part of the energy of steam can be converted into mechanical energy. The rest is given to the cooling water by condensing the vapor in the condenser. In our example, we assumed that the energy transferred to the turbine rotor would be about

38%, which roughly corresponds to the state of affairs in modern power plants.

When converting mechanical energy into electrical energy due to the so-called Joule losses in the windings of the rotor and stator of the electric generator, about 2% of the energy will be lost. As a result, about 36% of the initial energy will flow into the electric network.

The law of electromagnetic induction, Faraday's law - the law establishing the relationship between magnetic and electrical phenomena. EMF of electromagnetic induction in the circuit is numerically equal and opposite in sign to the rate of change of the magnetic flux through the surface bounded by this contour. The magnitude of the induced EMF depends on the rate of change of the magnetic flux.

Faraday's laws (after the English physicist M. Faraday (1791-1867)) - the basic laws of electrolysis. Establish a relationship between the amount of

electricity passing through the electroconductive solution (electrolyte) and the amount of matter released on the electrodes. When passing a constant current I through the electrolyte for a second, $q = It$, $m = kIt$. The second law of FARADAY: the electrochemical equivalents of the elements are directly proportional to their chemical equivalents. The rule of a borer is a rule that allows one to determine the direction of the magnetic field, depending on the direction of the electric current. When the translational movement of the drill with the flowing current coincides, the direction of rotation of its handle indicates the direction of the magnetic lines. Or, if the direction of rotation of the handle of the borer is identical with the direction of the current in the circuit, the translational movement of the borer indicates the direction of the magnetic lines piercing the surface bounded by the contour.

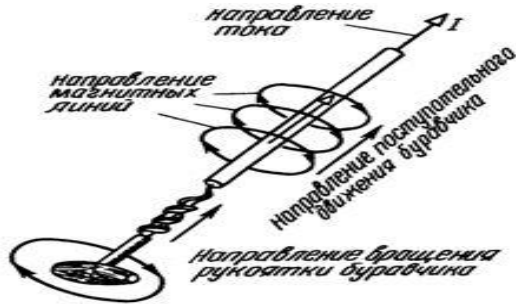

Rule drills

The rule of the left hand is the rule that allows to determine the direction of the electromagnetic force. If the palm of the left hand is positioned so that the vector of magnetic induction enters it (four fingers extended coincide with the direction of the current), then the right thumb thumb of the left hand shows the direction of the electromagnetic force.

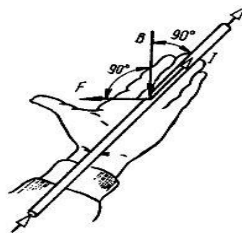

The rule of the left hand

The rule of the right hand is a rule that allows one to determine the direction of the induced emf of electromagnetic induction. The palm of the right hand is positioned so that the magnetic lines enter it. The thumb bent at right angles is aligned with the direction of movement of the conductor. The elongated four fingers indicate the direction of the induced EMF.

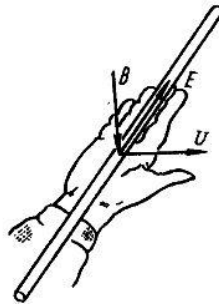

Rule of the right hand.

LECTURE 3. SOURCES OF ELECTRICITY.

Lecture plan:

3.1. Sources of electricity and their role in telecommunications.

3.2. Primary and secondary sources.

3.1. Sources of electricity and their role in telecommunications.

Energy saving is the implementation of legal, organizational, scientific, industrial, technological and economic measures aimed at the efficient use of energy resources with the involvement of renewable energy sources in the economic circulation. Energy saving in technology is carried out in the manufacture, operation, repair, utilization of products, performance of work. Energy intensity is a quantitative characteristic of energy (fuel) consumption for the

main technological processes of manufacturing, repair, utilization, and performance of work. The energy rationality of structures in terms of their energy consumption is estimated by energy intensity. Energy consumption is the cost of energy (fuel) when using products, installations, etc. by appointment. Energy costs include all energy costs for a given technological or economic facility, reduced to conventional fuel.

For energy costs, the product or process can be energy-efficient or uneconomical, and the use of energy resources is efficient (energy-efficient technology) or inefficient. If the requirements of standards, technical conditions and passport data are not observed, unproductive consumption of energy resources is possible. Energy saving indicators provide quantitative characteristics of energy saving measures and are based on energy consumption and

energy intensity indicators. They can be absolute, specific, relative, comparative.

As a basic relative indicator, the efficiency is usually used. The absolute energy saving indicators are: fuel or energy consumption, power consumption, power losses, voltage drop in the nominal mode, idling and short circuit losses. Specific indicators of energy conservation include: efficiency, specific fuel or energy consumption per unit of output (or energy), ratio of losses to nominal capacity, utilization factor.

Energy saving is characterized by: (1) energy consumption indicators (for example, energy consumption of a household refrigerator of 0.5 kWh per day), (2) energy intensity indicators (for example, 80 kWh of electricity, 20 kg of standard fuel, etc., are consumed in the production of a household refrigerator, etc.), (3) indicators of energy content (for example, the energy content of 1 kg of biogas produced by the pyrolysis of manure is 20 MJ, or the

energy content of 1 kg of gasoline obtained in the distillation of oil is 47 MJ).

Depending on the source of energy (raw materials), the following main types of power plants are distinguished: thermal power plants (TPP), hydraulic (HPP) and nuclear (NPP). In addition, geothermal, wind, solar, tidal, gas turbine, diesel, gasoline and other small power plants are used to generate electric and thermal energy. The main purpose of power plants (ES) is the production of electrical energy for supplying it with industrial and agricultural enterprises, municipal services and transport. Many ES provide enterprises and residential buildings with thermal energy (steam and hot water). The electrical energy produced by the ES is measured in megawatt-hours (MWh), the capacity of power plants is in megawatts (MW). The main parameters of electrical energy are voltage and current. Voltage is

measured in volts (kilovolts), current - in amperes (kiloamperes).

Thermal energy is measured in kilocalories (gigacalorie), and its main parameters are temperature (T, ° C) and pressure (P, MPa). In particular, the steam temperature at the inlet to the steam turbines can reach 650 ° C, and the pressure - 25 MPa. Note that $1 \text{ MPa} = 1 \text{ MN} / \text{m}^2 = 10 \text{ kgc} / \text{cm}^2 = 10 \text{ atm.} = 10 \text{ bar.}$

Thermal power plants (TPPs) are the basis of the electric power industry. Electric and thermal energy on them is produced as a result of conversion of thermal energy released during the burning of organic fuel. According to the type of power equipment installed at the TPP (the type of the primary engine), they are divided into steam turbine, gas turbine and diesel. Combined circuits with steam turbine and gas turbine units, called steam and gas plants, are also used. Gas turbine and combined-cycle TPP have

limited application, although they have a very valuable property - high maneuverability.

Diesel and gasoline power plants are used, as a rule, only as autonomous power stations, backup and emergency energy sources. Steam turbine TPPs are the main power plants of most power systems and are divided into condensing power plants (IES) and district heating plants (CHPs). IES are designed only for power generation and have purely condensation-type turbines. For large IES, the term GRES is used historically, the State District Power Plant. At IES, steam turbines with a deep vacuum in the condenser are installed, since the lower the vapor pressure at the outlet of the turbine, the greater part of the energy of the working medium is converted into electricity

In this case, the main vapor stream condenses in the condenser and most of the energy contained in it is lost with the cooling water. Due to large losses of

energy for cooling the coolant, the efficiency of IES reaches only 35-40%.

At modern IES, power units "boiler-turbine-generator-transformer" operate. Capacities of power units of KES: 150, 200, 300, 500, 800, 1200 MW. On a number of IES, economically unprofitable turbogenerators with a capacity of 25, 50, 100 MW have been preserved.

IES on high-quality fuel with a large calorific value (gas, fuel oil, the best grades of coal) have, if possible, near the centers of electricity consumption. IES on low-quality fuel (peat, brown coal) is more convenient to locate near the source of fuel.

CHP plants are designed for combined generation of electricity and heat in the form of hot water and (or) steam derived from the selection of turbines. The efficiency of the CHP plant can reach 70-75%.

The power and composition of the CHP units are determined by the parameters of thermal loads. The largest aggregates have a power of 100, 135, 175, 250 MW and are made in block scheme. The capacity of the CHPP, as a rule, does not exceed 500 MW, however, for heat supply of large cities, there may be more and reach 1250 MW (for example, Mosenergo TPP-22).

Due to the inexpediency of long-distance heat transfer (over 50 km), CHP plants are usually built near a consumer of heat - industrial plants or residential areas.

In the case of separate production of electricity and heat, electricity is generated at the IES, and heat energy plants (boiler rooms) are used for heat supply. Hydraulic power stations (HPPs) are designed to generate only electricity and, like expensive power plants, are usually built as part of hydrotechnical complexes that simultaneously solve the tasks of

navigation, water supply, irrigation, etc. The largest hydroelectric power stations are built in Siberia: Krasnoyarskaya HPP (6 million kW with units 500 MW), Sayanskaya HPP (6.4 million kW with 640 MW units). In the European part of the Russian Federation, the most powerful are the Volgograd hydroelectric power station (2.5 million kW) and the Samara HPP (2.3 million kW).

To increase the maneuverability of power systems, large pumped storage power plants (HPPPs) are involved in aligning the daily schedule of electrical load. The first of this series in the Russian Federation is the Zagorskaya GAES with a capacity of 1.2 million kW with 200 MW units. Nuclear power plants (NPPs), like TPPs, can be condensation power plants (AES) and heat and power plants (ATECs). In recent years, in some countries where there is a lack of fresh water, much attention is paid to the use of the

heat of combined atomic plants for the desalination of marine and solonchak waters.

Atomic energy can also be used only for heat supply purposes. Such nuclear power plants (ACTs) are already available in a number of countries. At nuclear power plants, as well as in power plants operating on fossil fuels, the process of converting the energy contained in the working medium (steam) into electrical energy is carried out. The difference between the processes occurring at nuclear power plants and thermal power plants is only that in one case the energy released during the decay of the nuclei of heavy elements (used as fuel) is used, in the other case when fuel is burned.

At nuclear power plants, power reactors are mainly used on thermal (slow) neutrons. In the unit with 440 MW units, 2 turbine units with a capacity of 220 MW are installed, with 1000 MW reactors - 2 turbine units with a capacity of 500 MW. Nuclear

power plants are always built near large industrial consumers of electrical energy. At such power plants, the mass of fuel consumed is small (thousands of times lower than at TPPs) and transporting it even over long distances does not significantly affect the cost of electricity.

Primary and secondary sources of energy supply

The power supply system (SE) is an integral part of industrial, household and other equipment for various purposes; it is a complex of elements and devices that generate electrical energy and transform it into a form that is necessary for normal operation of radio equipment. The existing classification provides for the division of solar cells into sources of primary and secondary power supplies.

The sources of primary power supply are devices that convert various types of energy into electrical energy. These include: electric engine generators,

galvanic cells, thermoelectric generators, solar and nuclear (nuclear) batteries; in these devices, the mechanical, chemical, thermal, light and energy of intra-atomic decay are used as primary energy, respectively.

Sources of secondary power supply (IWEP) are devices that use electric power received from a primary power source and form a secondary power supply of equipment. Sources of secondary power supply consist of function nodes that perform one or more functions, for example rectification, stabilization, amplification, control, inverting, etc.

The simplest IWEPs include uncontrolled adjusters, performed according to the structural scheme represented in Figure 1, a. The power transformer converts the AC mains voltage to the required value; rectification schemes convert the variable voltage into a pulsating one, the filter smooths the ripple of the voltage to an acceptable

level.

In unregulated rectifiers, the output voltage depends on the oscillation of the supply voltage and on the change in the load current. Such rectifiers are widely used in industrial and household radio electronics.

To ensure a stabilized output voltage, the unregulated rectifier circuit is supplemented with a voltage stabilizer, which is turned on at the input or at the output of the rectifier (Figure B.1, b), which can be used as continuous (NSN) or pulsed voltage regulators

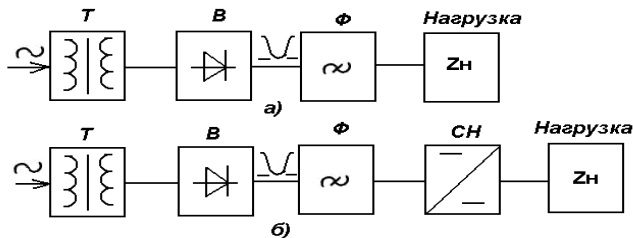

Fig. 1 - Structural diagrams of rectifiers.

Unregulated rectifier.

Unregulated rectifiers are non-stabilizing functional nodes of the IWEP, therefore the voltage at

their output depends on the voltage fluctuations in the supply network and the change in the load current. Such rectifiers are widely used in industrial and household radio electronics and make it possible to vary the output voltage relatively simply by changing the transformer ratio of a power transformer; In addition, the power transformer provides electrical isolation of the load circuit of the rectifier from the alternating current network, which in some cases is mandatory for the normal operation of radio electronic equipment.

In cases where, for the purposes of normal operation of radio equipment, it is necessary to provide a higher stability of supply voltages in comparison with the stability of the alternating current network, rectifier circuits are supplemented with stabilizing devices. They are switched on at the input or at the output of the rectifier; in the latter case (Fig.

1, b) continuous (linear) and pulsed constant voltage stabilizers (ISNs) are used as the stabilizer (SN).

In regulated rectifiers (Figure 2), the rectification functions are combined with regulation or with stabilization of the output voltage. Output voltage regulation (Fig. 2, a) is performed by changing the angle of opening of the power thyristors. In the stabilization mode of the output voltage of the rectifier (Fig.2, b), the control signal is generated by a loop of automatic control with feedback.

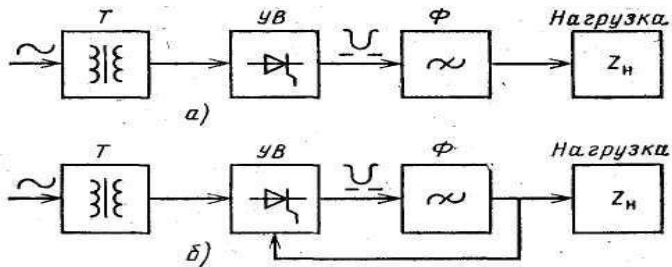

Fig. 2. Adjustable Rectifiers

Currently, in connection with the need to drastically reduce the mass and dimensions of the IWEP, power supply devices with a transformerless input (Figure 3) are widely used, and, as a rule, they

are stabilizing IWEPS. The regulation and transformation of the voltage are carried out in them at an increased frequency - the frequency of inverter conversion (10 - 20 kHz), while the inverter transformer provides isolation of the load circuit from the network. In the circuit in Fig. 3b, unlike Fig. 3, the functions of the pulse stabilizer and inverter are combined in a controlled inverter.

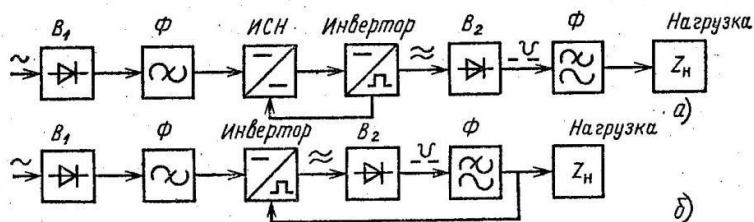

Fig. 3. Mains power supplies with transformerless input

In addition to the main functional units, the IVEP's practical schemes also include monitoring, protection, interlocking and fault signaling devices, as well as switching elements: buttons, switches, switches, etc. The total capacity currently consumed

by all IWEPs of scientific, technical and household radio equipment is very high, that's why the creation of economical, cheap and reliable IWEP is an extremely important people's economic task.

LECTURE 4. TYPES OF ELECTRIC POWER SOURCES.

Lecture plan:

4.1. Types of sources of electrical energy.

4.2. Renewable and non-renewable sources of energy.

Traditional and non-traditional energy sources.

To quantify the potential of the energy source use the concepts of resource and reserve. The resource of an energy source is usually called the whole of its volume, which in principle it is possible to isolate and convert to the desired form of energy. The stock of the energy source is its volume, which can be isolated and converted into the required form of energy in practice.

Practical allocation and transformation is determined by economic expediency, that is, this

process can be terminated if it becomes economically unprofitable. For example, all oil in the bowels of the Earth has the properties of burning and processing into petroleum products (diesel and gasoline). Therefore, all the deposits of fossil oil (explored and forecasted) constitute a resource of terrestrial sources of this type of energy.

In practice, any oil field can not be completely drained for economic reasons, when production becomes unprofitable, despite all the efforts made to improve it. Thus, each source of oil has a certain reserve, which is always less than its resource. The same applies to renewable energy sources. For example, the energy of photons, which is the essence of the energy of solar radiation, is fundamentally the same in any part of the globe, including oceans and polar latitudes. However, the practical use of solar energy is inappropriate in polar regions and in the ocean.

In the first case due to its smallness, and in the second case, due to the high transportation costs. As we see from the examples given, the energy source's supply turns out to be less than the resource for economic reasons, which, undoubtedly, can change in the course of technical evolution, leading to changes in the size of the stock.

But in any case, the reserve will always be less than the resource, since there will be more preferable conditions for the development of alternative energy sources. Consumption of energy resources makes sense to analyze from the moment of their industrial use. Reserves of crude oil, lying in sedimentary rocks, are estimated at 180 - 290 billion tons. Figure 1 presents statistical data on world oil production and consumption and a forecast for the future.

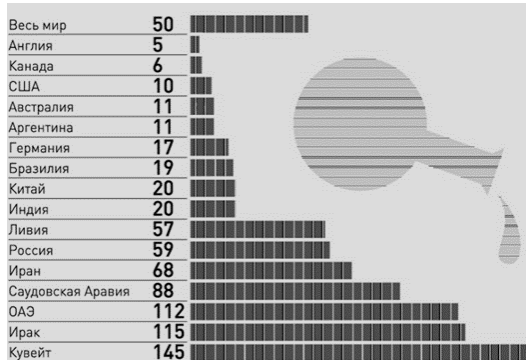

Much better forecasts for coal reserves. Its world reserves are estimated at 7,700 billion tons by many estimates. However, the period of extraction and use of coal is about 1000 years, and its large-scale use is more than 200 years. This has led to the fact that coal has become hard to reach, and its extraction has recently become more expensive, although it is still the main source for electricity generation.

Until recently, namely, until 1986, the most promising fuel was nuclear. According to various estimates, its reserves (although not renewable) would last for many hundreds of years, and with the search for the possibility of using the ^{238}U isotope in nuclear

power plants (NPPs) for several millennia. At present, nuclear fuel of nuclear power plants is enriched with natural uranium and artificially produced plutonium. Natural uranium consists of two isotopes - ^{235}U , which in natural uranium is about 0.7%, and ^{238}U , which in natural uranium is 99.3%.

After the Chernobyl disaster, the attitude towards nuclear fuel became ambiguous, although at the end of time many countries of the World began to incline in favor of a significant increase in the number of nuclear power plants, regarding nuclear energy as the main in the transition period before the global application of renewable energy sources. Here 4.2. Renewable and non-renewable sources of energy

We will begin the analysis of the resources of renewable energy sources from hydropower reserves, which, although it refers to renewable energy sources (hydropower of solar origin), but it is used quite widely and long enough. Due to this circumstance, it

occupies an intermediate position between traditional and non-traditional sources of energy.

it should be noted that, according to forecasts, renewable energy sources in the future should become predominant, and then uncontested, that is, according to the adopted terminology, they will become traditional ones. There are also other (pessimistic) forecasts, in which RES in the composition of used energy carriers is not more than 30%. The world reserves of hydroelectric power, that is, the part that is justified economically, is 10 billion tons of standard fuel per year, which is approximately equal to the entire world energy consumption at present. It should be noted that in the world as a whole, hydropower reserves for centralized power supply are almost completely realized. The reserves of hydropower for autonomous (non-systemic) power supply remain largely unrealized. The most powerful source of renewable energy is the Sun. Moreover, all other

sources of energy (traditional and non-traditional) owe their existence to the Sun. The total power of solar radiation is $4 \cdot 10^{26}$ W.

This exceeds the most daring forecasts of world energy consumption in the 21st century by hundreds of times. Solar energy, depending on the season of the year can be used throughout the globe. However, there are climatic zones with a large annual number of sun hours, in which the use of solar energy is most effective. Renewable energy is present in the environment in the form of energy, which is not a consequence of a person's purposeful activity.

Renewable energy resources include energy:

- the sun;
- the world's ocean in the form of tidal energy, wave energy;
- rivers;
- Wind;
- sea currents;

- seaweed;
- produced from biomass;
- drains;
- Solid domestic waste;
- already existing in the surrounding space;
- geothermal sources.

The disadvantage of renewable energy sources is the low degree of its concentration. But this is largely compensated by the widespread, relatively high ecological frequency and their practical inexhaustibility. Such sources are most rational to use directly near the consumer without transferring energy to a distance. Energy working on these sources uses energy flows to redistribute, but does not violate their overall balance.

Production From 2004 to 2013, electricity produced in the European Union from renewable sources rose from 14% to 25%. Hydroelectric power is the largest source of renewable energy, providing

3.3% of global energy consumption and 15.3% of global electricity generation in 2015. The use of wind energy is growing by about 30 percent per year, worldwide with an installed capacity of 318 gigawatts (GW) in 2013, [5] and is widely used in Europe, the US and China. [6] photovoltaic panels is rapidly increasing, in 2008 panels with a total capacity of 6.9 GW (6900 MW) were produced, which is almost six times higher than in 2009 [7].

Solar power stations are popular in Germany and Spain. [8] Solar thermal stations operate in the US and Spain, and the largest of them is a station in the Mojave Desert with a capacity of 354 MW. [9] The world's largest geothermal plant is the installation on geysers in California with a nominal capacity of 750 MW. Brazil is hosting one of the largest renewable energy programs in the world, related to the production of fuel ethanol from sugarcane. Ethyl alcohol currently covers 18% of the country's demand

for automotive fuel [10]. Fuel ethanol is also widely distributed in the United States.

Large non-resource companies support the use of renewable energy. So, IKEA is going to fully provide itself by 2020 with renewable energy. Apple - the largest owner of solar power plants, and through renewable energy sources, all the company's data centers operate. The share of renewable sources in the energy consumed by Google is 35%. The company's investments in renewable energy exceeded \$ 2 billion.

Classification of renewable energy sources.

Renewable energy sources (RES) are energy resources of constantly existing natural processes on the planet, as well as energy resources of products. the vital activity of biocenters of plant and animal origin. A characteristic feature of renewable energy sources is the cyclic nature of their renewal, which allows the use of these resources without time constraints. Typically, renewable energy sources include the

energy of solar radiation, water, wind, biomass, thermal energy of the upper layers of the earth's crust and the ocean.

RES can be classified according to the types of energy: [3]

- mechanical energy (wind energy and water flows);
- thermal and radiant energy (energy of solar radiation and heat of the Earth);
- chemical energy (energy contained in biomass).

The potential of renewable energy is practically unlimited, but the imperfection of technology and technology, the lack of the necessary structural and other materials does not yet allow to widely involve renewable energy in the energy balance. However, in recent years, scientific and technical progress has been especially noticeable in the world in the construction of installations for the use of renewable energy sources and, first of all, photovoltaic

transformations of solar energy, wind power units and biomass.

The feasibility and scale of the use of renewable energy sources are determined primarily by their economic efficiency and competitiveness with traditional energy technologies. There are several reasons for this:

- Inexhaustibility of RES;
- No need for transportation;
- RES - are environmentally beneficial and do not pollute the environment;
- Lack of fuel costs;
- Under certain conditions, in small autonomous power systems, renewable energy sources may prove to be more cost-effective than traditional resources;
- There is no need for water in production.

Also, the benefits of switching to "green" energy include eliminating the risks associated with nuclear energy (the possibility of accidents, the problem of

radioactive waste disposal), reducing the consequences of a possible energy crisis, reducing costs for non-renewable resources, primarily oil and gas, and reducing emissions greenhouse gases. Thus, the need to use renewable energy sources is determined by such factors:

- Depletion of explored reserves of fossil fuels in the near future;

- pollution of the environment with nitrogen and sulfur oxides, carbon dioxide, pulverized residues from combustion of produced fuel, radioactive contamination and thermal overheating when using nuclear fuel;

- rapid growth in demand for electrical energy, the consumption of which may increase several times in the coming years.

Wind energy

It is an energy industry specializing in converting the kinetic energy of air masses in the atmosphere into

electrical, thermal and any other form of energy for use in the national economy. The transformation takes place with the help of a wind generator (for electricity), windmills (for obtaining mechanical energy) and many other types of aggregates. Wind energy is a consequence of the sun, so it refers to renewable energy.

The power of the generator depends on the area swept out by the generator blades. For example, turbines with a capacity of 3 MW (V90) have a total height of 115 meters, a tower height of 70 meters and a blades diameter of 90 meters. The most promising places for energy production from the wind are the coastal zones. In the sea, at a distance of 10-12 km from the shore (and sometimes further), offshore wind farms are being built. Tower-generators are installed on foundations of piles, slaughtered to a depth of 30 meters.

Wind generators practically do not consume fossil fuels. The operation of a wind generator with a capacity of 1 MW for 20 years of operation makes it possible to save approximately 29 thousand tons of coal or 92 thousand barrels of oil.

In the future, it is planned to use wind energy not by means of wind generators, but in a more non-traditional way. In the city of Mysdar (UAE), it is planned to build a power plant operating on a piezoelectric effect. It will be a forest of polymer trunks covered with piezoelectric plates. These 55-meter trunks will bend under the influence of wind and generators.

All wind installations can be divided into 2 large types: with the vertical axis of rotation of the rotor and with the horizontal axis. VES with a vertical axis of rotation (on the vertical axis, a wheel is mounted on which the "receiving surfaces" for the wind are fixed), unlike the winged ones, can operate in any direction

of the wind without changing their position. Wind turbines of this group are slow, so they do not create much noise. They use multipolar power generators working at low speed, which makes it possible to use simple electrical circuits without the risk of an accident with an occasional gust of wind.

The main disadvantages of such units is their short rotation period and low efficiency as compared to horizontal wind farms. To the side effects of the operation of such installations should be attributed to the presence of low-frequency vibrations arising from the imbalance of the rotor. Units with a horizontal axis of rotation are a traditional arrangement of windmills. They use blades that rotate under the influence of the wind flow. The system is installed in the most favorable position in the wind flow with the help of a stabilizer wing. At powerful stations operating on the network, an electronic yaw control system is used for this.

The disadvantages of such a system are a high noise level, a loss in the mechanical transmission of energy, a reduction in the duration of equipment operation. Also, with strong gusts of wind, the blades can get significant damage or, at all, break down.

The wind energy market is one of the most dynamically developing in the world. Its growth for 2016 is 31%.

Hydropower At these power plants, the potential energy of the water flow is used as an energy source, the source of which is the Sun, evaporating water, which then falls on the hills in the form of precipitation and flows downwards, forming rivers. Hydroelectric power stations are usually built on the banks, constructing dams and reservoirs. It is also possible to use the kinetic energy of the water flow on so-called freely flowing (demotinous) HPPs.

Features:

- The cost price of electricity at HPPs is significantly lower than in all other types of power plants

- HPP generators can be turned on and off quickly enough, depending on the energy consumption

- Renewable energy source

- Significantly less impact on the air environment than other types of power plants

- Construction of a hydroelectric power station is usually more capital intensive

- Often, effective hydropower plants are more remote from consumers

- Reservoirs often occupy large areas

- are Norway, Iceland and Canada.

The most active hydropower construction in the early 2000s is led by China, for which the dam's power often changes the nature of the farm because it blocks the way to the spawning fish, but is often

avored by increasing fish stocks in the reservoir itself and by fish farming.

Types of HPP:

- Dense
- Intense
- Small
- Pumped storage
- Tidal
- On ocean currents
- Wave
- Osmotic

In 2010, hydropower provides production of up to 76% renewable and up to 16% of all electricity in the world, the installed hydroelectric capacity reaches 1015 GW. Leaders in the development of hydropower for a citizen is the main potential source of energy, in the same country there are up to half of the world's small hydroelectric power stations.

If one describes the operation of a hydropower plant, its principle is to generate energy by a turbine rotated by means of a falling water from an indefinite height. The hydraulic turbine converts the energy of water flowing under pressure into mechanical energy of shaft rotation. There are different designs of hydroturbines, corresponding to different flow velocities and different pressures of water, but they all have only two lobed wreaths.

The axis of rotation of the turbine, designed for high flow and low head, is usually located horizontally. Such turbines are called axial or propeller. In all large axial turbines, the blades of the impeller can be rotated in accordance with changes in pressure, which is especially valuable in the case of tidal hydroelectric plants, always operating under variable head conditions. Turbines are installed depending on the pressure head of the water flow at the HPP.

Hydroelectric stations are divided depending on the power output:

- Powerful - produce from 25 MW to 250 MW and higher;
- Medium - up to 25 MW;
- Small hydro power plants - up to 5 MW.

The power of the hydropower plant directly depends on the water pressure, as well as on the efficiency of the generator used. Due to the fact that according to natural laws the water level is constantly changing, depending on the season, and also for a number of reasons, it is customary to take the cyclic power as an expression of the power of the hydroelectric station. For example, distinguish between the annual, monthly, weekly or daily cycles of a hydroelectric plant.

There are also pumped storage power plants. They are able to accumulate the generated electricity, and to use it at times of peak loads. The principle of

operation of such power plants is the following: at certain moments (times of no peak load), the PSP units operate as pumps, and pump water into specially equipped upper basins. When there is a need, water from them enters the pressure pipeline and, accordingly, drives additional turbines.

In hydroelectric stations, depending on their purpose, additional structures, such as locks or ship lifts, facilitating navigation along the reservoir, fish-passing, water intake facilities used for irrigation, and much more can also be included.

Energy of the ebb and flow

Power plants of this type are a special type of hydroelectric power station that use tidal energy, and in fact the kinetic energy of the Earth's rotation. Tidal power plants are built on the shores of the seas, where the gravitational forces of the Moon and the Sun change the water level twice a day.

To obtain energy, the bay or the mouth of the river is blocked by a dam in which hydraulic units are installed that can operate both in generator mode and in pump mode (for pumping water into the reservoir for subsequent work in the absence of tides). In the latter case, they are called a hydroaccumulating power plant.

The advantages of PES are environmental friendliness and low cost of energy production. The drawbacks are the high construction cost and the capacity that changes during the day, because of which the PES can only work in a unified power system with other types of power plants.

Energy waves.

Wave power plants use the potential energy of waves carried on the surface of the ocean. Power wave is estimated in kW / m. Compared with wind and solar energy, wave energy has a greater specific power. Despite the similar nature with the energy of

tides, ebbs and ocean currents, wave energy is different from the source of renewable energy. Energy of sunlight

This type of energy is based on the conversion of electromagnetic solar radiation into electrical or thermal energy. Solar power plants use solar energy directly (photovoltaic systems operating on the phenomenon of internal photoeffect), and indirectly using the kinetic energy of the vapor.

The SES of indirect action includes:

- Tower - concentrating the solar light-heliostatamine central tower, filled with saline solution.

- Modular - on theseSES, the coolant, as a rule, is fed to the receiver in the focus of each parabolic-cylindrical mirror concentrator and then transfers the heat to the water by evaporating it.

Geothermal energy

Power plants of this type are used to supply power plants that use hot thermal springs as a heat carrier. In connection with the lack of the need for water heating, GeoTES are largely more environmentally friendly than TPPs. GeoTES is being built in volcanic areas where, at relatively shallow depths, water overheats above boiling point and seeps to the surface, sometimes appearing in the form of a geyser. Access to underground sources is carried out by drilling wells.

Bioenergetics.

This branch of energy specializes in the production of energy from biofuels. It is used in the production of both electric energy and thermal energy.

Biofuel of the first generation.

Biofuel - fuel from biological raw materials, obtained, as a rule, as a result of processing biological waste. There are also projects of varying degrees of sophistication aimed at obtaining biofuel from

cellulose of various types of organic waste, but these technologies are in the early stages of development or commercialization.

Distinguish:

- solid biofuel (energy forest: firewood, briquettes, fuel pellets, chips, straw, husk), peat;
- liquid biofuel (for internal combustion engines, for example, bioethanol, biomethanol, biobutanol, dimethyl ether, biodiesel);
- gaseous (biogas, biohydrogen, methane).

Second generation biofuels.

Biofuel of the second generation - a variety of fuels, obtained by various methods of pyrolysis of biomass, or other fuels, in addition to methanol, ethanol, biodiesel produced from sources of raw materials of the "second generation". Rapid pyrolysis makes it possible to convert biomass into liquid, which is easier and cheaper to transport, store and use.

From the liquid, it is possible to produce automobile fuel, or fuel for power plants.

Sources of raw materials for second-generation biofuels are lignocellulose compounds that remain after the parts of biological raw materials suitable for use in the food industry are removed. The use of biomass for the production of second generation biofuels is aimed at reducing the amount of used land suitable for agriculture. The plants-sources of second-generation raw materials include:

Biofuel of the third generation.

Biofuel of the third generation - fuels derived from algae. In addition to growing algae in open ponds, there are technologies for growing algae in small bioreactors located near power plants. The waste heat power plant can cover up to 77% of the heat needs needed for growing algae. This technology of growing algae culture is protected from diurnal temperature fluctuations, does not require a hot desert

climate - that is, it can be applied practically to any operating thermal power station.

LECTURE 5. WIND ENERGY AND HYDROPOWER.

Lecture plan:

5.1. Wind power conversion devices.

Possibilities of using and implementing wind turbines.

5.2. Schemes and elements of wind energy production.

5.3. Ultimate capacity of wind turbines and ways to improve reliability.

Wind power conversion devices. Possibilities of using and implementing wind turbines

Wind power is a branch of the power industry that specializes in converting the kinetic energy of air masses in the atmosphere into electrical, mechanical, thermal or any other form of energy convenient for use in the national economy. Such a conversion can be carried out by such units as a wind generator (for

generating electric power), a windmill (for conversion into mechanical energy), a sail (for use in transport), and others.

Modern wind energy with its technical equipment is a well-established direction of energy. Wind power plants ranging from kilowatts to several megawatts are serially produced in Europe, the USA, Russia and other countries of the world. The main part of such installations is used for power generation both in a unified power system and in autonomous systems. As will be shown below, with wind speed U_0 and air density ρ a windwheel sweeping area A develops power:

$$P = C_p A \frac{\rho U_0^3}{2}$$

where C_p is a parameter characterizing the efficiency of the use of wind energy by wind energy and called the power factor. Typically, the average annual output, taken from the unit of the wind wheel

area, is proportional to C_p , air density and medium velocity cube, i.e. $P \sim C_p \rho v^3$.

The maximum design capacity of the wind power installation (VEU) is calculated for some standard wind speed. Usually this speed is approximately 12 m / s. In this case, from 1 m² of the swept area is removed about 300 W at a value of C_p from 0.35 to 0.45. In Table. 7.1 presents the classification and main characteristics of wind turbines of different classes.

In areas with favorable wind conditions, the average annual electricity production is 25 ... 33% of its maximum design value.

Parameters of wind turbines of various design capacity at a wind speed of 12 m / s.

VEU class Design (design) power, kW

Wind turbine diameter Rotation period T, s

Small 10 ... 25 6.4 ... 10 0.3 ... 0.4

The average is 10 ... 100 ... 150 14 ... 20 ... 25 0.6
... 0.9 ... 1.1

Large 250 ... 500 ... 1000 32 ... 49 ... 64 1.4 ... 2.1
... 3.1

Very large 2000 ... 3000 ... 4000 90 ... 110 ... 130
3.9 ... 4.8 ... 5.7

The service life of the wind turbine is usually 15 ... 20 years, and their cost ranges from 1000 to 1500 US dollars per 1 kW of design capacity. One of the main conditions in the design of wind turbines is to ensure their protection against destruction by very strong random gusts of wind. Wind loads are proportional to the square of the wind speed, and once in 50 years there are winds at a speed exceeding 5 to 10 times the average, so the installation has to be designed with a large margin of safety.

In addition, the wind speed varies greatly in time, which can lead to fatigue failure, and for the blades,

alternating gravitational loads (about 107 cycles over 20 years of operation) are also important.

Brief classification of wind power plants

Wind power plants (WED) are classified according to two main characteristics - the geometry of the wind wheel and its position relative to the direction of the wind. In Fig. 7.1 shows the interaction of the air flow with the blade of the wind wheel and the resulting forces. If an air stream having a velocity u runs on a blade moving at a velocity V , then the flow velocity with respect to the blade will be v_r . When the flow interacts with the blade, there are:

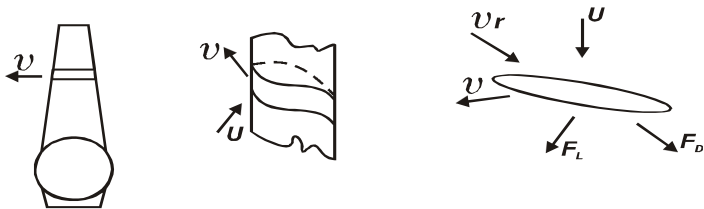

Fig. 5.1. Velocity of the blade element and acting on its forces (U is the wind speed, V is the velocity of the blade element, v_r is the speed of the blade element relative to the wind, F_D is the drag force acting in the

direction of the speed v , F_L is the lift force
perpendicular force F_D

Most often, wind turbines are classified according to the following characteristics (Fig. 5.2):

1. On the axis of the wind wheel relative to the wind current, the axis of rotation of the wind wheel can be parallel or perpendicular to the air flow. In the first case, the installation is called horizontally-axial, in the second - vertical-axial.

2. By the type of rotational force; Installations using force of resistance, as a rule, rotate at a linear speed less than the wind speed, and installations using lifting force have a linear velocity of the ends of the blades, which is substantially higher than the wind speed.

3. By geometric filling of the wind wheel; for the majority of installations it is determined by the number of blades. The wind turbines with a large

geometric filling of the wind wheel develop significant power with a relatively weak wind, and the maximum power is achieved with a small wheel speed.

Wind turbines with small filling reach maximum power at high speeds and require more time to enter this mode. Therefore, the first installations are used as drives of water pumps, and even with a weak wind they remain operational, the latter - as drives of electric generators, which require a high speed.

4. For a given purpose; installations for direct performance of mechanical work are often called a windmill or turbine; Installations for electricity generation, i.e. coupled turbine and electric generator are called a wind-electric generator, an air generator, or installations with energy conversion.

5. From the rotational speed of the wind wheel; there are two types of wind turbines connected to a powerful power system, the rotation frequency is

constant due to the auto-synchronization effect, but such installations use wind energy less efficiently than installations with variable speed.

6. By the type of coupling of a wind wheel with an electric generator; if the wind wheel is directly connected to the generator, then this connection is called hard; and if through a buffer, whose role is played by an intermediate energy store, then such a connection is called a partially unconnected connection.

The above classification of wind turbines based on the listed characteristics is shown in Fig. 7.2, but this does not exhaust all the variety of designs of these devices.

Some operating modes of the wind wheel
The efficiency of the conversion of the energy of the wind flow by the windwheel (Figure 7.3) will be lower than optimal if: 1) the blades are located so closely, or the wind wheel rotates so fast that each

blade moves in a stream turbulized by the forward blades; 2) the blades are so sparse, or the wind wheel rotates so slowly that a significant part of the airflow will come through the cross section of the wind wheel practically without interacting with its blades.

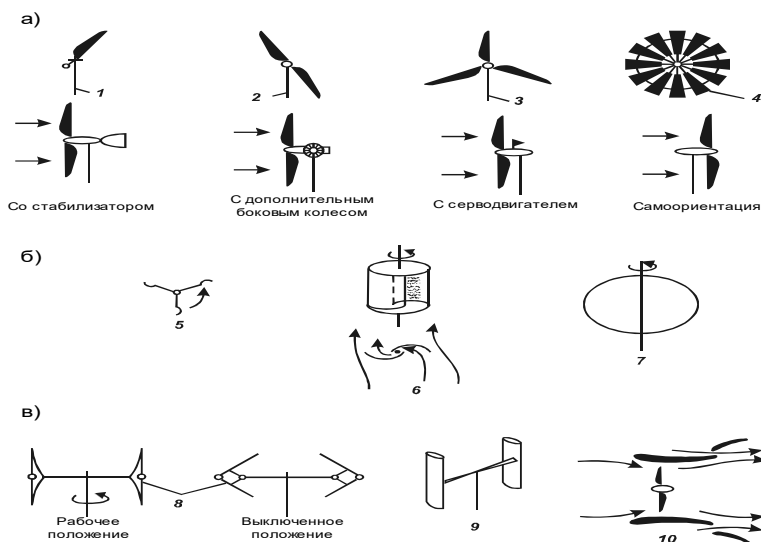

Fig. 5.2. Classification of windscreens: with horizontal axis (a); the vertical axis (b); with concentrators (amplifiers) of the wind flow (in); 1 - single-bladed wheel; 2 - two-bladed; 3 - lobed; 4 - multiblade; 5 - cup anemometer, 6 - Savonius rotor; 7

- the Dar'ev rotor; 8 - Masgruv rotor; 9 - Evans rotor;
- 10 - flow amplifier

From this it follows that in order to achieve maximum efficiency of the rotational speed of the wind wheel of a given geometry, its (frequency) must correspond to the wind speed. The efficiency of the wind wheel depends on the ratio of two characteristic types of time: time τ_B , for which the blade moves to a distance separating it from the adjacent blade, and the time τ_w , during which the vortex generated by the blade will move to a distance equal to its characteristic length.

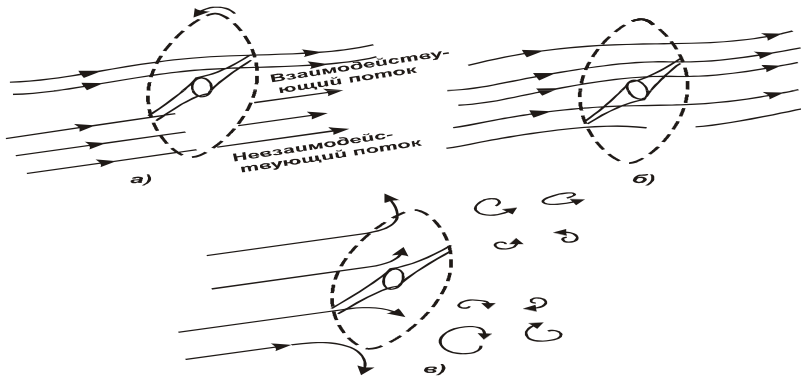

Fig. 5.3. The interaction of the wind flow with the wind wheel at a different frequency of its rotation: the rotation frequency is small, therefore part of the wind flow passes through the plane of the wind wheel without interacting with its blades (a); the speed is optimal, the whole flow interacts with the wind wheel (b); the rotation frequency is too high, in this case the wind flow is intensely turbulized, i.e. its energy is dissipated (in)

Schematics and Elements of Wind Power Production

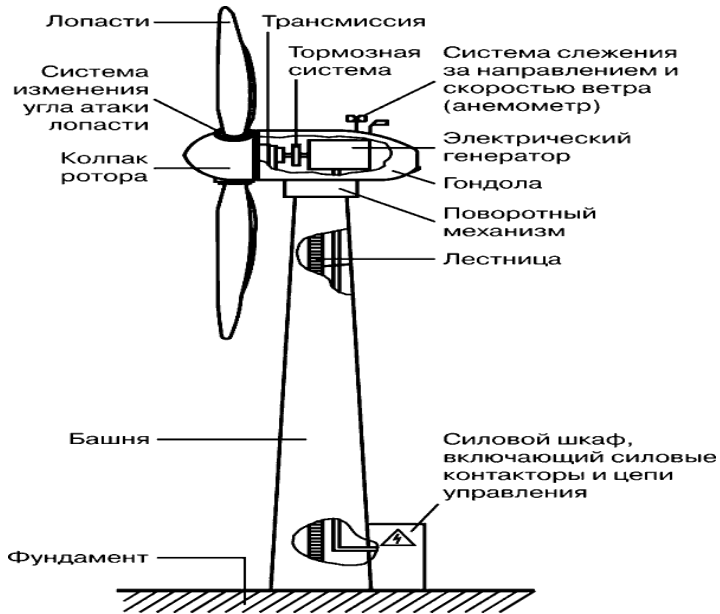

Fig. 5.4. Schematics and Elements of Wind Power Production

With the growth of power plants, their influence on the electric network has increased. In modern wind turbines, two types of wind turbines are mainly used: on the basis of asynchronous dual-power generators or gearless wind turbines based on a synchronous generator, in which problems of smooth start-up,

consumption or output of reactive power, voltage stabilization are solved.

Limit wind power and ways to improve reliability

The power of the wind generator depends on the power of the air flow, determined by the wind speed and swept area, $N = pSV^3/2$

where: - wind speed, - air density, - swept area.

The technical result is an increase in the aggregate power and efficiency of the wind turbine, increasing the reliability of the rotor wind turbine with full-bladed blades, as well as reducing the material consumption and cost of the entire structure. The positive effect of using a wind turbine is as follows. Given that the energy intensity of the wind under normal conditions is relatively low, to obtain an industrial electric current, it is necessary to create a device that has large surfaces of working planes, which increases its overall dimensions and weight.

In practical operation, extreme wind forces in storm values can not be used, but the installation in the prepared state must withstand these impacts. To this end, the support structure is divided in the proposed design of the wind turbine: on the peripheral annular, receiving the main mass of the installation and the effect of the wind, and the central point of the support, which receives the weight of the central part of the installation, which is the energy concentrator and the transmitting device to the main generator. Such a concept allows to create a large capacity unit capable of withstanding extreme loads and ensuring an increase in the reliability of the entire design.

LECTURE 6. SOLAR ENERGY.

Lecture plan:

6.1. Solar radiation.

6.2 Polycrystalline and single-crystal energy converters.

6.3. Photodetectors. Photocells with internal and external photoeffect.

6.4. Regulated limits of converted solar energy.

The highest flux density of solar radiation coming to Earth is approximately $1 \text{ kW} / \text{m}^2$ in the wavelength range $0.3 \dots 2.5 \text{ }\mu\text{m}$. This radiation is called short-wave radiation and includes the visible spectrum.

The flux of radiation energy coming into the atmosphere from the Earth's surface is also of the order of $1 \text{ kW} / \text{m}^2$, but they overlap another spectral

range - from 5 to 25 μm , called long-wave, with a maximum of about 10 μm .

The solar spectrum can be divided into three main areas:

1) ultraviolet radiation ($\leq <0.4 \mu\text{m}$) - 9% of the intensity;

2) visible radiation ($0.4 \mu\text{m} < \lambda < 0.7 \mu\text{m}$) - 45% of the intensity;

3) infrared radiation ($\lambda > 0.7 \mu\text{m}$) - 46% of the intensity;

The contribution to the solar radiation flux of radiation with a wavelength of more than 2.5 μm is very small, therefore all three regions are short-wave radiation. Distinguish between direct and scattered solar radiation.

In practice, the direct rays from the diffuse component differ in that the directed flux can be focused. Even on a clear day there is some amount of scattered radiation. The ratio of the intensity of the

directed flux to the total radiation intensity varies from 0.9 (on a clear day) to zero (on a very cloudy day).

Polycrystalline and single-crystal energy converters.

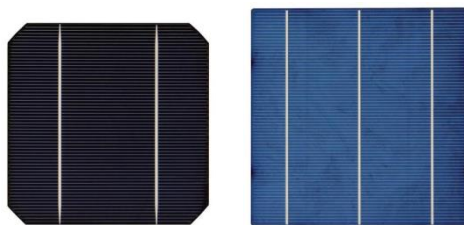

Fig. 6.1. Single-crystal element Polycrystalline element

The first thing that catches your eye is the appearance. In monocrystalline elements, the corners are rounded and the surface is uniform. Rounded corners are associated with the fact that in the production of monocrystalline silicon, cylindrical billets are obtained. The homogeneity of the color and structure of single-crystal elements is due to the fact

that this is one grown crystal of silicon, and the crystal structure is homogeneous.

In turn, polycrystalline elements have a square shape due to the fact that in the production of rectangular billets. The heterogeneity of the color and structure of polycrystalline elements is due to the fact that they consist of a large number of heterogeneous silicon crystals, and also include a small amount of impurities.

The second and probably the main difference is the efficiency of the conversion of solar energy. Monocrystalline elements and, accordingly, panels based on them have today the highest efficiency - up to 22% among the commercially available and up to 38% in the space industry.

Monocrystalline silicon is produced from high purity raw materials (99.999%).

The commercially available polycrystalline elements have an efficiency of up to 18%. The lower

efficiency is due to the fact that in the production of polycrystalline silicon not only primary silicon of high purity is used, but also secondary raw materials (for example, recycled solar panels or silicon waste from the metallurgical industry).

This leads to the appearance of various defects in polycrystalline elements, such as crystal boundaries, microdefects, carbon and oxygen impurities.

The efficiency of the elements is ultimately responsible for the physical size of the solar panels. The higher the efficiency, the smaller the panel area will be at the same power. The third difference is the price of a solar battery. Naturally, the price of a battery made of single-crystal elements is slightly higher per unit of power. This is due to the more expensive manufacturing process and the use of high purity silicon. However, this difference is insignificant and averages about 10%. So, let's list the main differences between single-crystal and

polycrystalline solar cells: Appearance, Efficiency, Price.

As can be seen from this list, for a solar power plant it does not matter what kind of solar panel will be used in its composition. The main parameters - the voltage and power of the solar panel do not depend on the type of elements used and it is often possible to find panels of both types of the same power. And if it does not confuse the heterogeneous color of the elements and a little larger area, then probably he will choose cheaper polycrystalline solar panels.

If these parameters are of importance to him, then the obvious choice is a slightly more expensive single-crystal solar panel.

The production of solar cells according to the type of silicon used in them was distributed as follows:

1. polycrystalline - 52.9%
2. monocrystalline - 33.2%

3. amorphous and the like - 13.9%

That is, polycrystalline solar batteries occupy the leading positions in the world in terms of production volume. Today, single-crystal elements are 1.5-2 times more expensive than polycrystalline elements.

Photodetectors. Photocells with internal and external photoelectric effect

Solar power plants (SES) can use different types of FEP, but not all of them satisfy the set of requirements for these systems:

- high reliability at long service life (up to 25-30 years);
- high availability of raw materials and the possibility of organizing mass production;
- acceptable from the point of view of the payback period of the costs of creating the conversion system;
- minimum energy and mass costs associated with the management of the energy conversion and

transmission system (space), including the orientation and stabilization of the station as a whole;

- ease of maintenance.

Photoelectric conversion of solar energy takes place in photocells or solar cells - semiconductor devices, in which there is a spatial separation of positive and negative charge carriers when the semiconductor absorbs solar electromagnetic radiation.

The main technical requirements for photocells:

- The starting material must be chemically pure with stable properties.

- Photovoltaic cells must be serially produced and have a minimum cost.

- The service life should not be less than 20 years in conditions of environmental impact at temperatures from -30 to + 200 ° C. The electrical contacts must be stable and protected from corrosion and moisture.

- Destruction of one element should not lead to failure of the whole system (parallel, serial connection, shunting diodes).

- Prefabricated modules must be transportable.

The liquid electrolyte can be used as the front surface of the photocell. This provides good electrical contact, but differs in the complexity of manufacturing, low KPD. and rapid contamination.

Photocells based on cadmium sulphide can be made by vacuum deposition of thin films of copper compounds. The pn junction is easily destroyed due to the diffusion of copper ions. There are designs of vertical multi-transitive cells with a serial or parallel connection of transitions. In a column, up to 100 similar transitions are connected in series or in parallel. Light penetrates through the side surfaces of the transitions. E.D.S. at the output is the sum of E.D.S. individual elements.

Materials for the manufacture of semiconductors and the structure of the photocell:

The conversion of energy into photovoltaic cells is based on the photoelectric effect that occurs in inhomogeneous semiconductor structures (that is, in a photocell consisting of two semiconductors of different conductivity) upon exposure to solar radiation.

To obtain this effect, special substances are used - semiconductors. They are of two types: with p- and n-conductivity. N-conductivity means an excess of electrons in the substance, p-, respectively - their lack

As mentioned above, the conversion efficiency depends on the electrophysical characteristics of the inhomogeneous semiconductor structure (photocell) and also the optical properties of the photovoltaic cells (photoelectric converters), among which photoconductivity plays the most important role. Among photovoltaic plants, several types are

conventionally distinguished according to the material used in production (in order of decreasing efficiency):

- Gallium arsenide (rigid, heavy modules with an efficiency of 10-25%, remain operative up to temperatures + 150 ° C, spectrum 0.5-0.9 - "visible", expensive);

- monocrystalline silicon and polycrystalline silicon (rigid, the efficiency of 12-20% - decreases with heating - 0.45% / ° C counting from + 25 ° C, spectrum 0.5-1.0 - "visible + infrared");

- Amorphous silicon (flexible batteries, efficiency 5-10%, spectrum 0.2-0.7 - "ultraviolet + visible");

- sulfide-cadmium (thin-film - flexible, the efficiency of 5-10% - is stable to temperatures + 100 ° C, the spectrum is 0.2-0.7- "ultraviolet");

- CIGS - copper, indium, gallium and selenium. The main disadvantage of gallium arsenide is its high cost.

Silicon is still the main material for the production of photocells. In general, silicon (Silicium, Silicon) is the second most abundant element on Earth, its reserves are huge. However, in its industrial use there is one big problem - its cleaning. This process is very laborious and expensive, so pure silicon is expensive. Now we are looking for analogs that would not be inferior to silicon in terms of efficiency. The compounds of copper, indium, selenium, gallium and cadmium are considered promising, as well as organic photocells.

On the basis of silicon are produced photo panels of three types:

1. From single crystals. To produce them, single crystals with a homogeneous structure are grown. As a result, such photocells differ in a uniform surface and, as a result, absorb sunlight better. In other words, their efficiency is higher than that of other species, but they are somewhat more expensive. These cells have

the form of squares with oblique angles or polygons, which is explained by the shape of the single-crystal silicon preform.

2. Of polycrystals. Such cells have an inhomogeneous, polycrystalline structure. Their light absorption is slightly lower than that of monocells, since the uneven surface reflects part of the rays. 3 On thin films. The principle of operation of such solar cells is similar to that of crystalline ones. But they are produced in the form of flexible cells, which can be installed on curvilinear surfaces. These batteries are cheap in production, and quite effective, but for household purposes they are rarely used, because in comparison with crystalline ones they occupy a large area (about 2.5 times) per unit of power.

Polycrystalline thin films are also very promising for solar energy. Extremely high ability to absorb solar radiation in copper and indium diselenide (CuInSe_2) - 99% of the light is absorbed in the first

micron of this material (the width of the forbidden band is 1.0 eV).

Photoelectric effect and solar panels
The essence of the photoelectric effect is the transformation of solar energy into a constant electric current. There is it as follows. Electrons of certain substances (for example, silicon) are capable of absorbing the energy of the sun's rays. As a result, they leave their orbits, forming a directed stream. This directed flow of electrons is a constant photocurrent.

To obtain this effect, special substances are used - semiconductors. They are of two types: with p- and n-conductivity. N-conductivity means an excess of electrons in the substance, p-, respectively, is their lack. To create a photocell, two differently conductive semiconductors are needed. They are placed one on top of another, forming a two-layer structure. In other words, a kind of electrode battery is obtained, in

which the role of the cathode is played by an n-conductor, and the anode is a p-conductor.

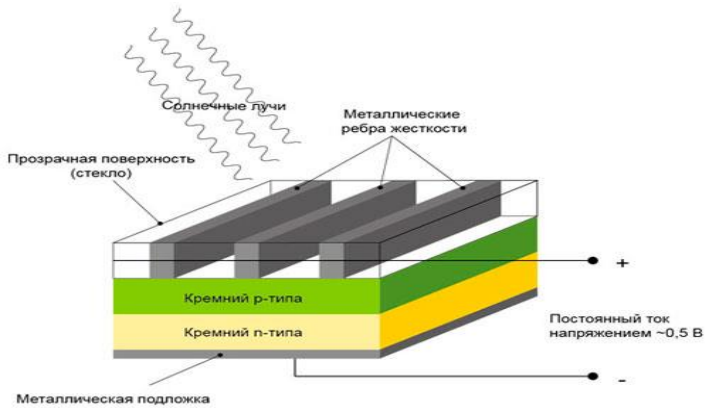

Fig. 6.2. solar panel structure

The further principle of the action of the photocell is based on the formation of the p-n junction region at the interface of semiconductors. Under the action of incident rays, the electrons of the n-conductor (which is located at the top of the structure) leave their atomic orbits. They go to the p-layer, where there is a shortage of electrons. Thus, a directional flow of electrons arises, it is also a photocurrent.

To remove the current to the plates of semiconductors, thin conductors and a load are connected. Such a system can work for a very long time, since its operation on is connected with chemical interactions, and therefore there is no destruction of materials. Photo-based semiconductor-based aluminum substrate, two layers of semiconductors with different conductivity, protective anti-reflection glass and negative electrodes (Figure 6.3.). To the layers from different sides, the contacts that are used to connect to the external circuit are soldered. The role of the cathode is played by a layer with n-conductivity (electron conduction), the role of the anode is the p-layer (hole conduction).

The principle of the photocell

The contact of p-or n-semiconductors leads to the formation of a contact electric field between them, which plays an important role in the work of a solar photocell.

Let us consider the cause of the contact potential difference. When a p-type and n-type semiconductor single crystal is joined together, a diffusion electron flux from the n-type semiconductor to the p-type semiconductor arises and, conversely, the hole flux from p- to the n-semiconductor. As a result of this process, the part of the p-type semiconductor adjacent to the pn junction will be charged negatively, and the portion of the n-type semiconductor adjacent to the pn junction acquires a positive charge.

Thus, near the pn junction, a double charged layer forms, which counteracts the diffusion of electrons and holes. Indeed, diffusion tends to create a flow of electrons from the n-region to the p-region, and the field of the charged layer, on the contrary, returns the electrons to the n-region. Similarly, the field in the p-n junction counteracts the diffusion of holes from the p- to the n-region. As a result, an

equilibrium state is established: in the p-n junction region

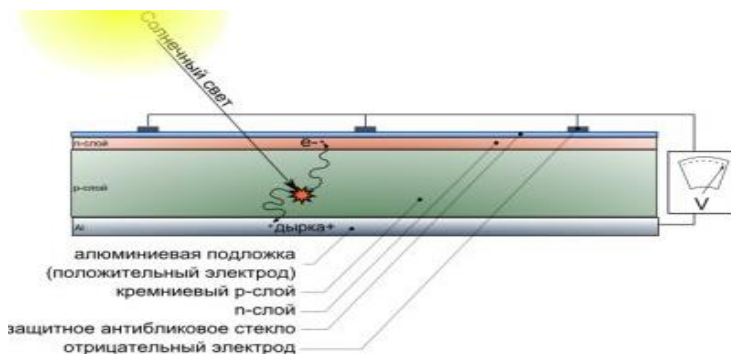

Fig. 6.3. Structure of the photocell

A potential barrier arises to overcome which electrons from the n-semiconductor and holes from the p-semiconductor must spend a certain energy. Let us consider the operation of the p-n junction in photocells. When light is absorbed, electron-hole pairs are excited in the semiconductor. In a homogeneous semiconductor, photoexcitation only increases the energy of electrons and holes without dividing them in space, that is, electrons and holes are separated by "energy space", but remain in a geometric space.

To separate the current carriers and the appearance of the photoelectromotive force (photo-EMF), there must be an additional force. The most efficient separation of nonequilibrium carriers occurs precisely in the region of the pn junction. The "non-primary" carriers (holes in the n-semiconductor and electrons in the p-semiconductor) generated near the pn diffuse to the pn junction, are picked up by the pn junction field and are emitted into the semiconductor in which they become the main carriers: the electrons will be localized in an n-type semiconductor, and holes in a p-type semiconductor.

As a result, a p-type semiconductor receives an excess positive charge, and an n-type semiconductor is negative. Between the n and p regions of the photocell, a potential difference is created - a photo-EMF or a voltage in the idle mode. The polarity of the photo-emf corresponds to a "direct" displacement of the pn junction, which lowers the height of the

potential barrier and promotes the injection of holes from the p-region into the n-region and electrons from the n-region to the p-domain. As a result of the action of these two opposing mechanisms-the accumulation of current carriers under the action of light and their outflow due to the lowering of the height of the potential barrier- for different light intensities, a different value of the photoelectric power is established. The magnitude of the photoelectric power in a wide range of illumination rust.

When the illuminated p-n junction is short-circuited, a current proportional to the intensity of illumination and the number of electron-hole pairs generated by light will flow in the electric circuit. When the payload is included in the electrical circuit, the magnitude of the current in the circuit decreases somewhat. Typically, the electrical resistance of the payload in the solar cell circuit is selected so as to

obtain the maximum electrical power output to this load.

Regulated limits of converted solar energy

When light is absorbed by a semiconductor structure, spatial separation of positive and negative current carriers occurs, and in a closed circuit this device is the source of electrical energy. The internal fields of photocells based on semiconductor-semiconductor or metal-semiconductor structures create a potential difference of about 0.5 V and a current density of the order of $200 \text{ A}\cdot\text{m}^{-2}$ at a flux density of solar radiation of about $1 \text{ kW}\cdot\text{m}^{-2}$.

Industrial photovoltaic cells have an efficiency of 10 to 20% with average irradiance and can produce from 1 to 2 $\text{kW}\cdot\text{m}^{-2}$ of electricity per day. These devices on semiconductor junctions are usually called photocells or solar cells. They themselves are sources of EMF. It is important to note that photovoltaic devices are sources of electrical energy that work

from the flux of solar radiation. Solar cells generate current in direct dependence on daily, seasonal and random changes in irradiance. The efficiency of using solar energy depends not only on the efficiency of the photocell, but also on the consistency of the dynamic load in the external circuit.

Features of an electrical circuit containing a solar photocell

Solar cells, like any other current generators, can be used to generate electricity. In Fig. 6.4. an equivalent circuit of the circuit containing the solar cell is shown.

Thus, at any load, including batteries, the best combination of parameters is achieved even when using load control devices at maximum power. These devices are DC-DC converters. Their application in the circuit allows us to achieve a useful consumption in a load of 95% of the maximum output power under various conditions of irradiation of the solar battery.

A solar cell battery is typically a combination of parallel modules. Each module, in turn, consists of series-connected photocells. And each photocell consists of parallel-connected surface elements (Figure 6.6.).

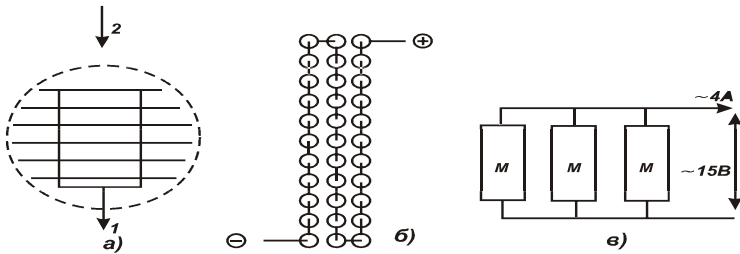

Fig. 6.4. Schemes of typical industrial solar cells: element (a); module of 33 elements (b) and battery (c)

The maximum voltage drop across the contacts of the open circuit of the module is approximately 15 V, the maximum current through the module is about 1.5 A with irradiation of about $1 \text{ kW}\cdot\text{m}^{-2}$. Obviously, there may be a situation where one of the elements will fail or the battery surface will be unevenly

illuminated due to varying degrees of light concentration or presence of a shadow.

In this case, the device will operate in diode mode with forward or reverse bias and, of course, can overheat. In order to prevent avalanche breakdown, it is necessary to install shunt diodes parallel to each line of the photocell chains. It is assumed that, with proper and competent operation, the accident-free operation of commercial solar batteries will be long enough, and their service life will be 25 years.

LECTURE 7. ELECTRICAL NETWORKS AND SYSTEMS

Lecture plan:

7.1. Electrical networks and systems.

7.2. Electric stations and substations.

7.3. Transmission and distribution of information.

Electrical networks and systems

Power supply refers to providing consumers with electricity, a power supply system - a set of electrical installations designed to provide consumers with electricity. The power supply system can be defined as a set of interconnected electrical installations that provide electricity to the district, city, or enterprise.

The standard consumer, which sets forth the terms and definitions of energy and electrification, is an enterprise, an organization, a geographically

separate shop, a construction site, an apartment in which the electricity receivers are connected to the electric grid and use electrical energy. We will adhere to this definition, considering it more correct. The receiver of electricity is a device (apparatus, unit, mechanism) in which the conversion of electrical energy into another type of energy is used for its use.

For technological purposes, power receivers are classified according to the type of energy into which this receiver converts electric energy, in particular: electric motors of machinery and mechanisms drives; electrothermal and electric power installations; electrochemical installations; installation of electric lighting; installation of electrostatic and electromagnetic fields, electrostatic precipitators; sparks, electronic and computer machines, devices for monitoring and testing products.

Electrical installations are a combination of machines, devices, lines and auxiliary equipment

(together with the facilities and premises in which they are installed) intended for the production, conversion, transmission, accumulation, distribution of electrical energy and converting it into another type of energy. Electrical installation is a complex of interconnected equipment and structures. Examples of electrical installations: electric substation, power transmission line, distribution substation, condenser installation, induction installation.

The electrician has to create and operate various objects, not called electrical installations (lacquer storage, tool storage, cable storage area, electrical engineering department, household fire extinguishing systems, air intake and air ducts). They are subject to other safety rules and devices, building codes and regulations. Some of these objects are considered in the PUE, for example, pneumatic and oil facilities. For them, electricians act as technologists (the

requirements of the PUE are the basis of the task for design and construction).

Let's introduce the definition of the electrical economy of industrial enterprises, which represents a set of generating, transforming, transmitting electrical installations, through which the company supplies electricity to the enterprise and effectively uses it in the process of technological production. The electric economy includes: the actual power supply, which is sometimes called intra-plant power supply, power electrical equipment and automation, electric lighting, operation and repair of electrical equipment.

Electric economy is a set of installed and standby electrical installations, electrical and non-electrical products that are not part of the electrical network (circuit), but ensure its operation; electrotechnical and other premises, buildings, structures and networks, which are operated by electrical or subordinate personnel; it is also human, material and energy

resources and information support, which are necessary for the life of the electrical economy as a dedicated integrity. The electric economy includes a part of the electric power system, referred to the enterprise.

The energy system (power system) is a collection of power plants, electric and heat networks connected to each other and connected by a common mode in the continuous process of production, transformation and distribution of electricity and heat, with the overall management of this regime. The electrical part of the power system is the set of electrical installations of electric stations and electric grids of the power system.

An electrical grid is a set of electrical installations for transmission and distribution of electrical energy, consisting of substations, switchgears, current conductors, air and cable power lines operating in a certain area. The electric network

can be defined both as a set of substations and switchgears and connecting electric lines located on the territory of the district, populated place, electricity consumer.

A substation refers to an electrical installation serving for the transformation and distribution of electricity and consisting of transformers or other energy converters, switchgear, control devices and auxiliary structures. Depending on the transformation of a function, they are called transformer (TP) or transformative (PP). A transformer substation is called a complete transformer substation (KTP) - when transformers (converters), a low voltage switchboard and other elements are assembled or fully assembled.

The electrical substation is an electrical installation for the conversion and distribution of electrical energy. The distribution device (RU) refers to an electrical installation serving for receiving and distributing electric power and containing switching

devices, prefabricated and connecting buses, auxiliary devices (compressor, battery, etc.), as well as protection devices, automation and measuring devices. If all or basic equipment RU is located in the open air, it is called open (ORU), in the building - closed (ZRU).

A distribution device consisting of fully or partially enclosed cabinets and units with built-in devices, protection and automation devices, supplied in assembled or fully prepared for assembly, is called complete and is designated; for indoor installation - switchgear, for outdoor installation - KRUN. The distributing point is the switchgear intended for receiving and distributing electricity at the same voltage without conversion and transformation. For the voltage of 10 (6) kV, the equivalent concept of "distribution substation" (RP) is widely used in electricity supply practice. The distribution point with voltage up to 1 kV is usually called power (assembly).

A switchboard is a switchgear up to 1 kV, designed to control network lines and protect them. The control station is a complete device up to 1 kV designed for remote control of electrical installations or parts thereof with automated control, regulation, protection and alarm functions. Structurally, the control station is a block, a panel, a cabinet, a shield.

The control unit is a control station, all elements of which are mounted on a separate plate or frame. The control panel is a control station, all elements of which are mounted on boards, racks or other structural elements assembled on a common frame or metal sheet. The control panel (the control panel of the control stations-SCW) is an assembly of several panels or blocks on a three-dimensional frame. Control cabinet is a control station, protected from all sides in such a way that access to current-carrying parts is excluded with closed doors and covers.

Electric stations and substations

The system of supplying consumers with electricity is divided into three interrelated parts:

1) electric power stations that generate electricity by converting the energy of natural sources into electricity;

2) electric networks that transmit electricity from power plants and distribute it to consumers;

3) receivers that convert electrical energy into other types of energy, since electricity is used only as an intermediate form of energy, convenient for transmission and transformation.

The totality of power plants, electric grids and electric consumers, connected by a common production, is called an energy system. At some power stations, not only electric power, but also thermal energy is produced. Therefore, the power system also covers the installation of production, distribution and use of heat. The electrical part of the power system is called the electrical system. The part

of the electrical system that distributes the electric energy supplied from the power plants inside the enterprise and consumes it, i.e. converts electricity into energy of other types (thermal, mechanical, light, chemical) is called the power supply system of the enterprise. The power supply system includes:

- power sources of the enterprise with electricity;
- its electrical networks;
- control and regulation equipment for current and voltage;
- receivers of electricity.

The set of receivers of electricity in production, united by a common technological cycle, is called the consumer of electricity. Power sources of electrical systems are electric power stations, which, depending on the type of energy used by a natural source, are divided into thermal, hydroelectric, nuclear, as well as tidal, wind, geothermal, etc.

At thermal stations (TPP), the energy released from the combustion of coal, peat, shale, gas, oil and other types of fuels is converted into electricity by a basic process scheme. Extraction, delivery and preparation of fuel for combustion in boilers is a complex and expensive process. The heat energy obtained from the combustion of fuel is transferred to the water to produce high-pressure superheated steam (up to 30 MPa) and temperatures (up to 650 ° C) in the boiler.

The main disadvantages of TPPs are the complexity of processes and low efficiency. Only 30-40% of the heat obtained from the combustion of fuel is useful. And the rest of the heat (70-60%) is given to cooling water by condensing steam and flue gases. This energy is irretrievably lost. But this is in condensing stations (IES). There are also CHPP - combined heat and power plants. In them, there is an intermediate selection of steam from the turbine,

which is sent to consumers or used to produce hot water for heating. In the CHP, in this way, combined production and release of two types of energy - electric and thermal - is carried out. The total efficiency of heating plants, on which the main units are installed from 100 to 250 MW, is 60-75%

Nuclear power plants (AES) are also thermal steam turbine stations, but using a special type of fuel as a natural energy source - nuclear fuel. In the technological scheme the role of the boiler is performed by the atomic reactor. The heat released in the reactor during the fission of uranium or plutonium nuclei is transferred to the heat carrier - heavy water, helium, etc. Heat transfer energy is transferred from the heat carrier to the steam generator. Next - the same scheme for converting steam energy into mechanical energy of a steam turbine and into electrical energy as on a TPP.

At present, TPPs have a predominant development. This is due to lower specific investment and the timing of the construction of TPPs. Technical and economic indicators of nuclear power plants are between the indicators of TPP and HPP. The main element of diesel power plants (DES) is a diesel generator. As primary engines, non-compressor four-stroke and two-stroke diesel engines with a power of 5-1000 kW with a rotational speed of 375-15000 rpm are mainly used. Diesels are equipped with synchronous alternators. By appointment, DES is divided into main, reserve and emergency.

All power stations are equipped with generators, generating electricity at a voltage, which is called a generator. Generator voltage from 6.3 to 38.5 kV is less than the voltage of electric network lines, the most rational for transmission of electric energy over significant distances. Therefore, to increase the generator voltage, 500,000, 750 or 1,050 kV of the

power transmission line (through the power transmission lines) are being built in the substation. But since electric power lines are supplied to cities and industrial enterprises with 220, 110 and 35 kV power lines, powerful electric motors operate at 6 and 10 kV, and the nominal voltage of the majority of electric energy consumers is chosen equal to 220, 380 or 660 V, in several steps with the help of reducing substations. The basis of step-up and step-down substations are transformers. Transformers in power distribution systems are called power transformers. They have a nominal power from 10 kVA to 1 million kVA.

Receivers of electricity by voltage, current type and its frequency are divided into the following groups:

- receivers of three-phase current with voltage up to 1000 V, frequency 50 Hz;

- receivers of three-phase current with voltage above 1000 V, frequency of 50 Hz;
- receivers of single-phase current with voltage up to 1000 V, frequency 50 Hz;
- receivers operating at a frequency other than 50 Hz, receiving power from converter units;
- DC receivers receiving power from DC generators of local power plants.

Electrical networks with voltages above 1000V have the following nominal voltages: 6, 10, 20, 35, 110 and 220 kV.

By designation, networks

- feeding;
- distribution;
- local;
- District.

Feeders are called networks that transmit electricity from the grid to enterprises, including the main grid systems, i.e. 220 kV network and above.

Distribution networks are called networks, which are directly connected to electric receivers. These are networks with voltages up to 10 kV (sometimes 20 and 35). But the distribution networks are also called higher voltage networks (110-220 kV), if they feed a large number of receiving substations of deep injection (PGV) located on the territory of the enterprise.

Local electrical networks - networks that serve small areas with a relatively low load density, voltage up to 35 kV inclusive. District electric networks are networks covering large areas and connecting the power stations of the system to each other and to the load centers with a voltage of 110 kV and above.

Power Transmission and Distribution Devices

A feature of the process of production, transmission and consumption of electricity is its continuity. The process of electricity generation coincides with the process of its consumption,

therefore power plants, electric networks and consumers' electric consumers are connected by a common mode. The generality of the regime calls for the organization of energy systems. According to the design, electrical networks of fields are divided into air and cable lines. An air line (VL) refers to a device for transmitting and distributing electricity through wires laid open and attached insulators and reinforcement to supports.

A cable line is an electrical transmission device consisting of one or more parallel cables with connecting, locking and terminal couplings (clamps) and fasteners. Cable lines are laid in places where the construction of overhead lines is difficult, for example, in conditions of tightness on the territory of the enterprise, passage through structures, etc. The distribution device (RU) is an electrical installation for receiving and distributing electric power and containing prefabricated and connecting buses,

switching devices, protection devices, automatics and telemechanics, measuring instruments and auxiliary devices.

Distribution devices are divided into open (located in the open air) and closed (in the building). In urban conditions, in most cases, closed RUs are used. A substation is an electrical installation that serves for the transformation and distribution of electrical energy and consists of a switchgear up to and above 1000 V, power transformers or other electrical power converters and auxiliary structures.

The power center (CPU) is a distributor of the generator voltage of the power plant or the secondary voltage switchgear of the lowering substation of the power system, which has a voltage regulating device to which the electrical networks of the given area are connected. As can be seen from Fig. 8.1., The cable line from the CP is laid in the distributing point of the RP. This line, which has no distribution of electricity

along its length from the CPU to the RP, is called the supply cable line.

The distribution point is a 6-20 kV switchgear intended for receiving electric power from the CPU through the power supply lines and transferring it to the distribution network. The distribution center includes prefabricated and connecting buses, switching devices, protection devices, automatics and telemechanics, as well as measuring instruments. The distribution point can be combined with a transformer substation serving nearby consumers. From the distribution point, in different directions, cable lines RKL, feeding a number of transformer substations TP and departing distributive.

The transformer substation, which is an electrical installation in which electricity is transformed from a voltage of 6 - 20 kV to a voltage of up to 1000 V and is distributed at this voltage, consists of power

transformers, switchgears up to and above 1000 V, control devices and auxiliary structures.

The complete transformer substation (KTP) consists of transformers, a distributive (or input) 6-10 kV device, a 0.4 kV switchgear, current conductors between them, supplied in assembled or prepared for collection. An open transformer substation, all equipment of which is installed on high structures or power transmission line supports, is called column or mast (MTP). From the transformer substations directly to consumers, air lines or distribution cables of cable lines with voltage up to 1000 V, laid to the input-distributing devices (inputs) of the ASP or distribution boards located in the consumers' buildings depart.

From the entrances or switchboards in the houses are laid trunks (risers), from which, in turn, the lines of the distribution network through the apartments. The supplying cable lines can be routed from the CPU

not only in the RP, where there are no transformers, but also in the main step-down substations GPP plants, where electricity is distributed through distribution cable lines and converted by power transformers into electricity with a voltage of up to 1000 V.

In this case, power transformers and a distribution board with voltage up to 1000 V are installed at the GPP, from which the electric power is transmitted by bus-wires or wires laid on trestles or trays, or by cable lines directly to the shops and then to electric receivers. The city electric network includes electrical installations located on the territory of the given city, serving for the electric supply of current collectors and representing a set of supply lines from the CPU, RP and TP, distribution lines with voltage 6-10 kV and up to 1000V, input devices for consumers.

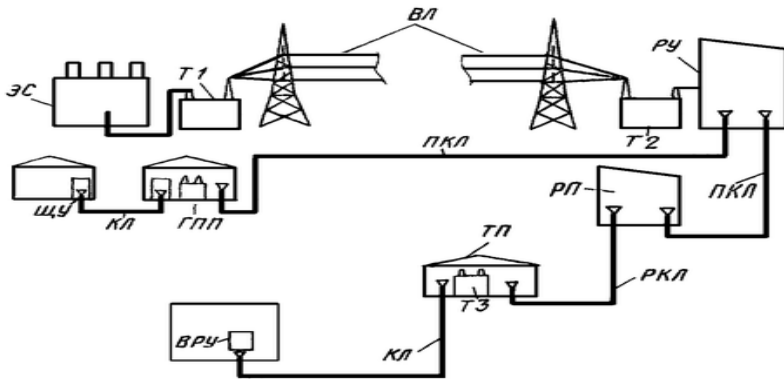

Fig. 7.1. ES - state district power station (GRES), T1 - step-up transformer at GRES, T2 - step-down transformer of power center, TZ - step-down transformer in TP, overhead line - voltage line 35-750 kV, RU - switchgear 6-10 kV of step-down substation (power center), PCL - supply cable line, distribution center - distribution point, RCL - distribution cable line, cable line - 0.4 kV cable line, ASP - input and switchgear in the residential building, GPP - main lowering substation of the plant, ЩУ - shield dog roystvo voltage of 0.4 kV in the factory shop.

LECTURE 8. METHODS OF REDUCING THE LOSS OF ELECTRIC ENERGY.

Lecture plan:

8.1. Methods for reducing the loss of electrical energy.

8.2. Devices of intellectual control.

Methods for reducing the loss of electrical energy

For an objective, technically and economically justified choice of measures to reduce losses of electric energy, as well as to determine the amount of financing the terms of implementation, schemes for the development of electric grids for the billing period should be developed and approved.

When developing development schemes, the following issues are considered and decisions made on them. Optimization of circuit modes.

The analysis of existing schemes in the part of building urban electric networks is carried out: two-beam; loop; mixed with the performance of electrical calculations and with the evaluation of two modes of electrical networks - for the conditions of the annual maximum and minimum loads, taking into account the points of the current division determined during the operation period in the normal and post-emergency modes. Calculate the loss of electricity in the elements of the network, in power lines, in transformers.

The balance of active and reactive powers at the nodes of the distribution of flows is determined. An assessment is given of the efficiency of the network on the loss of electricity, its quality in the consumer, the loading of the network with reactive power and its deficit, and the reliability of electricity supply. Taking into account the data on the growth of loads, existing consumers for the billing period, data on new declared

consumers, city development plans and long-term development, a development scheme for the settlement period is being developed, as well as its principles of construction, points of current divisions are being refined.

Electric calculations are again performed with an estimation of two modes of the electric network - for the conditions of the annual maximum and minimum load with the creation of a new balance of active and reactive capacities in the normal and post-emergency modes. Based on the results of electrical calculations and data obtained by technical audit, characterizing the physical condition of the electrical equipment of networks, the scope of work for its replacement, reconstruction and development of electric distribution networks necessary to bring them to a state that ensures optimal electrical losses, as well as the adaptation of networks to the growing electrical loads.

Electric calculations are carried out in the normal and post-emergency modes. Based on the results of the electrical calculations, the technical calculations and the data obtained by technical audit, characterizing the physical condition of the electrical equipment of networks, the scope of work for its replacement, reconstruction and development of electric distribution networks. electrical losses.

. The transfer of the network to a higher voltage class should be considered simultaneously with neutral operation modes (dummy-grounded or effectively grounded through a resistor), with such operating modes the neutral has less power loss due to the lack of additional equipment necessary to compensate for large capacitive currents. Compensation for reactive power. When developing schemes for the development of networks at the stage of determining the balance of active and reactive power at the nodes of the distribution of flows for the

accounting period, a deficit of reactive power is determined. Based on the calculated data, the scheme solves the issues of the necessary number of reactive power compensation devices, as well as the location of their location.

Priority is the placement of compensating devices directly from the consumer, since this fundamentally affects the power losses in the network and its quality in the consumer. The battery of statistical capacitors in this version of the plant is simultaneously a voltage regulation element. Voltage regulation in power lines. Regulation of voltage on the power centers should be carried out on the principle of counter regulation.

On long feeders, in order to reduce power losses and provide the proper voltage level, it is necessary to install capacitor banks with automatic control or booster transformers, as well as with automatic voltage regulation, as voltage regulators.

Application of modern electrical equipment that meets the requirements of energy conservation.

It is necessary to replace power transformers and auxiliary transformers in case they have large losses of electricity for magnetization reversal of the cores, transformers with less losses, and current-limiting reactors with modern ones with large inductive resistance to K3 currents and smaller losses in the normal mode. When developing working projects for the reconstruction and technical re-equipment, equipment meeting the energy-saving requirements should be laid. The use of transformers with cores made of amorphous steel will also reduce losses.

The use of current and voltage measuring transformers with a high accuracy class and the replacement of induction meters with electronic ones will allow obtaining more objective information about losses in electric distribution networks, thereby reducing the amount of commercial power losses.

The use of booster transformers as linear voltage regulators allows not only to reduce power losses in grids, but also solves the problem of adapting power transmission lines to changing electrical loads to the height of their growth - it will provide a normalized level of voltage for the consumer. Reduction of electricity consumption for "own needs" of electrical installations. Application for electrical heating of buildings and structures of substations, distribution points of transformer substations, etc. heating elements with heat accumulators, which allow to use electricity for heating in the nighttime non-peak period of the load schedule, will allow to partially reduce the consumption for own needs at electric grid facilities. Application for lighting of buildings and territories of fluorescent lamps with the maximum use of the so-called "duty light" mode. Introduction of automation and remote control of 6-20 kV electrical distribution networks.

Provides timely detection of unfavorable operating modes of the network and prompt elimination of these regimes in adverse situations of load schedules, allows to avoid emergency situations of mass disconnection of consumers. Avoiding the development of unfavorable regimes in electrical networks has a significant impact on the loss of electricity in networks. Switching devices, circuit breakers, load switches must be used on the basis of vacuum switches with programmable microprocessor control, which provides the functions of automatic reclosure, automatic reset, fixation of change in power flows.

Devices of intellectual control.

Modern complex of monitoring and control of power supply systems of facilities. SmartGrid is an actively-adaptive energy network. The development of innovative technologies, scientific and technological progress, production and, in general, the

life of modern man can not be imagined without electric energy. At the same time, the energy sector itself, which appeared more than a hundred years ago and was then the locomotive of development of production, technology, technology, is now less than other branches equipped with modern infocommunication facilities and automation systems.

In this regard, new basic approaches to building information systems of energy networks are developing in the world. So, in the last few years, in the West and in Russia, the conceptual framework, architecture, standards and principles of building "smart energy networks and systems", known in the world as "SmartGrid", or, as they are sometimes called in our country, are being actively studied, "Actively-adaptive networks" of energy. According to analysts, in the next 40 years the world's electric power consumption should increase by 3 times.

At the same time, there is a need to optimize energy consumption, at the same time it is necessary to change the mentality of users in relation to consumption of energy resources, in particular, to enable them to manage their energy consumption, organize online access to information on consumption (by analogy with cellular communication, banking services) P.

Technology of SmartGrid networks and intelligent devices.

The "SmartGrid" concept of energy networks being developed and implemented implies the development, upgrading and integration of basic infrastructure and equipment of different types of energy networks, including generation / transport / distribution / consumption of electricity based on IT infrastructure, modern information and communication technologies, communications, automation of management. Simultaneously,

SmartGrid integrates sources of distributed decentralized generation, power storage systems, distributed automation systems, control systems and monitoring, automated control systems for substations, distribution and consumption management systems, modern consumption meters, electric vehicles are being developed and implemented.

With the introduction of the architecture of building such energy networks, a number of significant innovative advantages appear. In particular:

- Bi-directional information and energy communication between electric grid companies and consumers
- Constant monitoring of network elements - from the operation of generation facilities to informing customers and managing the consumption of electricity by individual personal devices

- Wide use and integration of distributed generating capacities, including renewable ones
- Maximum use of existing technological equipment of power systems
- Self-diagnostics and self-restoration of power supply networks
- Security and resistance to external connections to the network
- Advanced control and management of consumer applications and equipment to reduce peak loads, optimize energy consumption and energy efficiency, select optimal tariff plans, create online services between the user and the power sales company
- Standardization of energy parameters, interfaces, interaction protocols

The introduction of global technologies and SmartGrid solutions at certain stages should ensure a significant increase in the quality of electricity

necessary for modern society, increase the reliability, stability and flexibility of the energy networks, and ensure the principle of matching the capacity of loads of generated capacity.

Given the volume of high-level tasks of intellectual energy, which, accordingly, will require serious investments in the energy sector, the introduction of SmartGrid technologies will occur not simultaneously, but for quite a long time, it can be years or even decades.

One of the basic components of SmartGrid is "intelligent electronic devices" (IED) and equipment, for example, programmable power quality control devices, built on the basis of high-performance microprocessors, which have sufficient memory, support for modern network interfaces and protocols (BACnet, Modbus, LON, Ethernet).

The most "advanced" devices have built-in web servers, color touch-displays, functions of a freely

programmable logic controller with various types of inputs and outputs and support work in various networks without the need for additional equipment and software.

The initial stage of development of SmartGrid is the introduction of modern monitoring and control devices, the creation of an automatic infrastructure of measuring networks at the level of consumers - apartments, premises, buildings and building complexes. At the same time, the task of automatic or automated load control can be solved. Moreover, the problem of distributed technical monitoring and management of the power supply of the object (building) as a whole, and for individual zones is solved.

Энергомониторинг

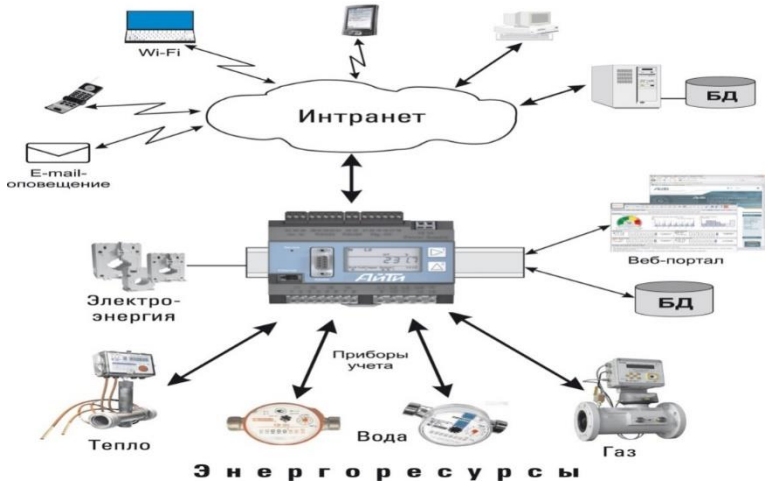

Fig. 8.1. Center for Monitoring and Controlling Power Supply Parameters of the Object

The presence of a multifunctional system "Center for Monitoring and Controlling Power Supply and Load Parameters" allows:

a) To conduct in real time a full analysis of electricity consumption (if necessary, other types of energy resources), both for individual zones of the facility in order to assess the energy efficiency of each

site, technological subsystem, and the object as a whole;

b) Manage the power consumption of the facility as a whole within the limits of the granted quotas (or contracts) for electricity supply through an automated load priority management system, which leads to the absence of costs associated with the payment of penalties (with appropriate contractual relations) for excessive (peak) electricity consumption, and improves overall reliability and efficiency of energy supply;

c) To fix in real time dozens of power quality parameters for each measured channel, in particular, the presence of a reactive component of electric power, harmonics, etc. The analysis of electrical parameters at various sites of the facility will help to identify places where there is a need to install additional equipment that adjusts the quality of power supply (in particular, reactive power compensators

with automatic adjustment and parameter selection), and reduce overall power consumption of the site, increase equipment efficiency and improve overall reliability of the systems;

d) Instantly record emergencies in the power system of the facility, or warn the operator and the power attendant about approaching the power supply parameters at the facility to critical values, which will avoid an emergency situation, take adequate measures in advance and ensure full continuous monitoring of the power supply system.

The package of such a solution usually includes specialized blocks of software:

- Programming, configuration and man-machine interface for working with systems;
- An analytical subsystem that allows the general accounting and analysis of energy consumption, the calculation and optimization of the cost of energy

resources for each accounting node, and also prepare and issue reports;

- Peak load monitoring and management system;
- System for monitoring the quality of power supply of the facility;
- Database management system (for medium, large and distributed objects).

The presence of a wide range of interfaces and communication protocols allows the exchange of data from the Center for Monitoring the Energy Supply of the facility with other software (software and hardware) complexes of the facility.

The available communication capabilities of the Center (such as e-mail, sms, remote Web access) allow almost instantly to inform the necessary circle of specialists and the management of the object, regardless of their location, the status of the work and all significant events (there is the possibility of setting up lists of events individually) occurring in the energy system of the object.

An example of another useful solution may be a system for monitoring and managing peak consumption (consumption currents).

An important point in configuring this system is to determine and agree on the types of loads that have the highest priority and increased requirements for reliability of power supply and allocation of loads that can be controlled and disconnected if necessary. For the second type of loads, the shutdown time is determined. Usually it can be short.

But, for example, computer equipment, control systems, process equipment, safety of objects can not be turned off under any conditions and should have the highest priority.

There are other systems for which it is possible to provide a shutdown for controlling peak capacities (including those with the possibility of smooth adjustment): compressors, water heaters, electric ovens, refrigerators, pool heating, boiler heating,

deicer, ventilation, floor heating, electric chargers,
sauna.

LECTURE 9. CONVERSION OF ELECTRIC ENERGY

Lecture plan:

9.1. Conversion of electrical energy.

9.2. Transformer operating mode.

Conversion of electrical energy

A transformer is a static electromagnetic device that converts the electric energy of an alternating current with one parameter into the electric energy of an alternating current with other parameters. Variable parameters can be: current, voltage, number of phases, shape of the voltage curve (in special transformers - frequency).

In power supply devices, the transformer is most often used to convert an alternating voltage of one value into an alternating voltage of a different magnitude. In terms of power, transformers are power

(for power from 1 kVA to hundreds of kVA) and low-power (from 1 VA to 1 kVA). Low-power transformers are used in communications equipment and radio equipment as matching or separation transformers or for the conversion of voltage or current. Power transformers are used in power circuits of radio enterprises and wire communication enterprises.

The transformer is an AC machine and does not work at DC! Any transformer consists of two basic elements - a closed steel core and windings wound with copper wire. The core of the transformer is made of plates of special electrical steel. The thickness of these plates depends on the operating frequency of the transformer, the higher the frequency, the thinner the plate.

According to the shape of the core and the method of positioning the windings on it, the transformers are rod, armor (Sh-shaped), toroidal and

ribbon-type. Post-discharge execution (i.e., according to the number of windings) the transformers are one-, two- and multi-winding. The winding included in the network of the source of electrical energy is called the primary winding, and the winding included in the network of the energy receiver (consumer) is called secondary. The primary winding of the transformer is only one, and there can be several secondary ones. One-winding transformer is called autotransformer (example - household transformer in stabilizer for TV).

Its secondary winding serves as a tap from the primary winding. There is a magnetic and electrical connection between the primary and secondary sides. The two-winding transformer has one primary and one secondary winding. They are electrically isolated from each other. The multiwindings transformer has one primary and several secondary windings, and all windings are not electrically connected to each other.

By working frequency, the transformers can be conditionally divided into transformers:

- reduced frequency (below 50 Hz);
- power frequency (50 Hz);
- increased frequency (100 Hz - 10 kHz);
- high frequency (above 10 kHz).

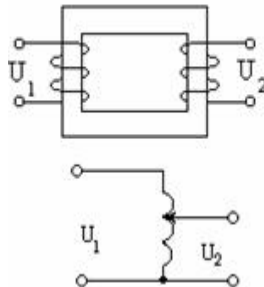
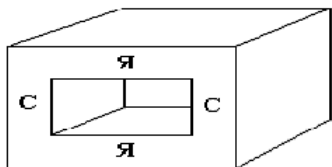

Fig. 9.1. Single-phase transformer

In terms of the number of phases, the transformers are single-phase (Figure 10.1.) And multiphase (three-phase, six-phase, etc.). The number of phases of the primary winding is determined by the number of phases of the source of electrical energy,

and the number of phases of the secondary winding is determined by the assignment of the transformer in the circuit. Voltage transformers are low-voltage (the voltage of any of its windings is less than 1000 V) and high-voltage (voltage of at least one above 1000 V). Transformer construction The main parts of the transformer are a steel closed core (magnetic core) and coils wound on it. The cores are: rod, armored, toroidal, ribbon cut (Figure 9.2.).

Стержневой



Броневой

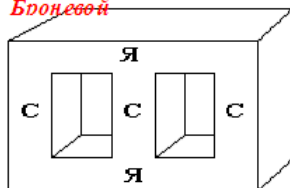

Ленточный



Fig. 9.2. Core core, armored, toroidal, belt

Those parts of the core on which the windings are worn are called rods, and those parts that serve to close the magnetic circuit and do not carry the windings are called yokes. In the core single-phase transformers, the windings are put on both bars (half of each winding by one and half by the other). In armor (III-shaped) single-phase transformers, both windings are put on the middle rod, and in three-phase primary and secondary windings of each phase is put on its rod.

Toroidal transformers are made only single-phase and low power. The material of the cores is plates of special electrotechnical (transformer) sheet steel E-41, 42, etc. The thickness of the sheets depends on the frequency of the transformer. For transformers operating at a frequency $f = 50$ Hz, steel sheets 0.5 or 0.35 mm thick are used, and for transformers operating at higher frequencies, steel sheets 0.2 to 0.08 mm thick are used. Since the

transformers operate on alternating current, in the steel cores eddy currents (Foucault currents) are induced, which lead to energy losses in the transformer steel.

To reduce these losses, the cores are not made by all-metal ones, but are made from thin plates, and these plates are covered with a layer of varnish (or glued on thin paper) on one side to isolate them from each other.

Rod cores are assembled from separate plates of rectangular shape. Armor cores are recruited from stamped W-shaped plates. Toroidal cores are made for low-power transformers (tens of watts) of increased frequency. Belt cuts in shape are similar to armored ones.

By the ratio of voltage transformation transformers are divided into lowering and raising. Principle of operation and operating modes of transformers

Consider it using the example of a two-winding core transformer (Figure 9.3).



Fig.9.3. Principle of operation of the transformer

The principle of the transformer is based on the electromagnetic interaction of two or more electrically unconnected and stationary windings. Windings are characterized by the number of turns W_1 and W_2 . For the transformer, there are three operating modes: idling, operating mode and short circuit. Let us consider successively these regimes.

Transformer idling

Idling - this mode of operation of the transformer, when the primary winding is connected to an alternating current source, and the secondary one is open, i.e. the secondary winding current is zero. Suppose that the voltage U_1 changes according to the sinusoidal law.

Under its action on the primary winding (with the number of turns W_1), a sinusoidal current $I_1 = I_0$, equal to the idle current, flows. The magnitude of the current I_0 depends on the power of the transformer; in low-power transformers (tens of VA), it reaches 25-30% of the rated current I_1 , and in high-power transformers it ranges from 3 to 10% of it. Under the action of I_1 , a magnetizing force $F_0 = I_0 W_1$ arises that creates a magnetic flux F in the transformer. Most of it closes around the transformer core and forms the main magnetic flux Φ_0 , which penetrates all the turns of the primary winding (with the number of turns W_1) and the secondary winding (with the number of turns

W2). A small part of the flow F closes through the air around the primary winding and forms a scattered flux of Φ_{1s} coupled only to This flux Φ_{1s} is induced in

the primary winding of the EMF $e_{1s} = -W_1 \frac{d\Phi_{1s}}{dt}$.

And the main magnetic flux Φ_0 is induced in the primary and secondary windings of the EMF

$$e_1 = -W_1 \frac{d\Phi_1}{dt} , \quad e_2 = -W_2 \frac{d\Phi_2}{dt}$$

If we assume that the flow Φ_0 is sinusoidal, i.e. $\Phi_0 = \Phi_{0m} \sin \omega t$, then the induced EMF according to (1) and (2) can be written as follows:

$$e_1 = - W_1 \omega \Phi_{0m} \cos \omega t = \omega W_1 \Phi_{0m} \sin (\omega t - \pi/2)$$

$$e_2 = - W_2 \omega \Phi_{0m} \cos \omega t = \omega W_2 \Phi_{0m} \sin (\omega t - \pi/2),$$

$$\text{there } \omega W_1 \Phi_{0m} = E_{1m}, \quad \omega W_2 \Phi_{0m} = E_{2m}.$$

That is, e_1 and e_2 also vary according to the sinusoidal law, but they lag behind the phase Φ_0 by an angle of $\pi / 2$. In practice, it is customary to operate

not by instantaneous, but by acting EMF values, they are determined by the formulas:

$$e_2 = -W_2 \frac{d\Phi_2}{dt}$$

$$E_1 = \frac{E_{1m}}{\sqrt{2}} = \frac{\omega W_1 \cdot \Phi_{0m}}{\sqrt{2}} = \frac{2\pi \cdot W_1 \cdot \Phi_{0m}}{\sqrt{2}} = 4.44 \cdot f \cdot W_1 \cdot \Phi_{0m},$$

$$E_2 = 4.44 \cdot f \cdot W_2 \cdot \Phi_{0m}$$

From the above formulas it is clear that the EMF of the primary and secondary windings are directly proportional to the number of turns of these windings, i.e. The larger the number of turns, the greater the EMF winding. The transformer is usually characterized by the relations $W_1 / W_2 = E_1 / E_2 = n$, which is called the transformation coefficient. It shows how many times the EMFs of the primary and secondary windings differ.

A winding having a greater number of turns is called a higher voltage winding, and a winding having

a smaller number of turns is called a lower voltage winding. If $W_1 > W_2$, then the transformer is called decreasing, if $W_1 \leq W_2$ - raising. Since the transformer consumes electric power from the network and does not create it, the electrical power taken from the network $S_1 = U_1 I_1$ is always greater, or equal to the electrical power on the secondary side of the transformer $S_2 = U_2 I_2$, i.e. $S_2 \leq S_1$. Therefore, the higher the voltage on the winding of the transformer, the less current there can be in it, i.e.

$$n = \frac{E_1}{E_2} \approx \frac{I_2}{I_1}$$

Transformer operating mode.

If the load is connected to the secondary of the transformer, the transformer will operate in the operating mode). In this mode, the physical processes in the transformer depend on the nature of the load. We will consider two main cases of active-inductive and active-capacitive loading. If the voltage is applied

to the primary winding \bar{U}_1 , and the secondary is connected to the load, currents \dot{I}_1 and \dot{I}_2 will flow on both windings, respectively.

They will introduce in the transformer magnetic fluxes Φ_{1s} and Φ_{2s} , which are mostly closed along the core of the transformer, and a small part of them closes in the air around the windings, forming scattering fluxes Φ_1 and Φ_2 . These currents will be introduced in the transformer in the windings of the EMF transformer of scattering \dot{E}_{1s} and \dot{E}_{2s} , which are spent on the inductive reactances of scattering x_1 and x_2 , the primary and secondary windings, that is

$$\dot{E}_{1s} = -j\dot{I}_1 x_1, \quad \dot{E}_{2s} = -j\dot{I}_2 x_2$$

In this case, the equilibrium equations for a loaded transformer will have the form

$$\begin{aligned} \bar{U}_1 &= -\dot{E}_1 - \dot{E}_{1s} + \dot{I}_1 r_1 = -\dot{E}_1 + j\dot{I}_1 x_1 + \dot{I}_1 r_1 \\ \bar{U}_2 &= \dot{E}_2 + \dot{E}_{2s} - \dot{I}_2 r_2 = \dot{E}_2 - j\dot{I}_2 x_2 - \dot{I}_2 r_2 \end{aligned} \quad (9.1)$$

Transformer short-circuit

A short-circuit of the transformer takes place if the secondary winding is short-circuited, and the primary winding is connected to the mains. Under operational conditions, a short circuit is an emergency mode and is accompanied by very large current surges. At the same time, the windings heat up strongly, and large mechanical forces act on them, deforming the windings.

But for transformers, a short circuit is being made. It is done to determine the transformer parameters at any load. In this experiment, the secondary winding is short-circuited, and the lower voltage U_k is applied to the primary, at which nominal currents appear in the transformer windings. This rated voltage is called the short-circuit voltage and is measured in% of the rated voltage, that is

$$U_k = \frac{U_k}{U_1} \cdot 100\%$$

According to the current standard,

$$U_k = (5.5 + 10.5)\%$$

Since the value of U_k is very small, the magnetizing current I_0 and, accordingly, the magnetic flux Φ_0 are insignificant, i.e., $I_0 k \approx 0$, while the magnetizing force of the primary winding is spent on compensating the magnetizing force of the secondary winding. If we neglect the magnetizing current (i.e., $I_0 k = 0$), then the equation of magnetic equilibrium takes the form $\dot{I}_1 W_1 + \dot{I}_2 W_2 = 0$, and if we consider the transformer as reduced, then $\dot{I}_1 = -\dot{I}_2$. Equation of equilibrium of the secondary winding will take the form $\bar{U}'_2 = \dot{E}'_2 - \dot{I}'_2 Z'_2 = 0$

LECTURE 10. RECTIFIERS

Lecture plan:

- 10.1. Structural diagram of the rectifier.
- 10.2. Single-phase and multiphase rectifiers.
- 10.3. Two-cycle rectification scheme with zero output of the secondary circuit of the transformer

Structural diagram of the rectifier.

The distribution of electric energy in our Republic is carried out at alternating current with frequency $f = 50$ Hz. At the same time, wire communication equipment is mostly supplied with a constant current of various voltages. Therefore, there is a need to convert AC to DC. Rectifiers are used for this. A rectifier is a static device that converts an alternating current into a constant one.

In general, the rectifier consists of 4 main links (Figure 11.1).



Fig.10.1. Structural diagram of single-channel rectifier

The transformer converts the AC mains voltage into the one that is necessary to obtain a given DC voltage at the output of the rectifier. The valves have a one-way conductivity and convert the alternating current into direct current. Their number in the rectifier depends on the rectification scheme. Each phase of the rectifier has at least one valve link. But there are circuits that have two or more gateways per phase. Each valve link must have at least one valve.

But in many cases, in order to obtain a given value of the current or voltage, each valve link must be composed of several valves connected in series, in parallel, or in more complex groups. The rectified

voltage or current after the valves turns out to be pulsating. Such a current can be represented as consisting of two currents: a direct current and an alternating current superimposed on it. When powering telecommunications equipment with pulsating direct current, serious interference may occur to the transmission of communication signals.

Because this is unacceptable, then usually take measures to reduce this ripple. For this purpose, a smoothing filter is placed between the valves and the power supply. The output voltage of the rectifier depends on the value of the AC supply voltage, and it can vary within (-10 ... 15%). Communication equipment most often does not allow such a significant voltage fluctuation, so in modern rectifiers after the filter put voltage regulators, and if necessary current. In addition to these links, every rectifier has switching equipment, protection, etc.

Gates and their parameters

Straightening of an alternating current into a direct current is carried out by a nonlinear element - a valve. The valve is a device that conducts electric current mainly in one direction. It has a high conductivity (ie, low resistance) for a current of one direction, and low conductivity (ie, high resistance) for a current in one direction. The direction in which the valve has a low resistance is called direct, it is characterized by the quantities R_{pr} , I_{pr} , U_{pr} . And the direction in which the valve has a large resistance is called the inverse and is characterized by the values of R_{ob} , I_{ob} , U_{ob} . The designation of a valve in the circuit is shown in Fig. 10.2:

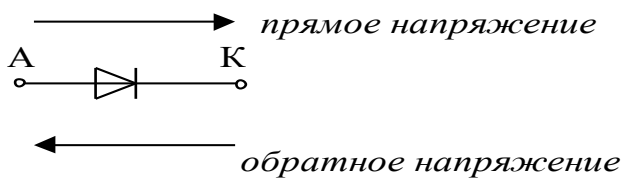

Fig. 10.2. The designation of the valve in the circuit.

The voltage from the anode to the cathode is called the direct voltage, and from the cathode to the anode it is called the inverse. There are ideal and real valves. The direction of the current through the valve and its basic electrical properties are expressed by the current-voltage characteristic (I-V characteristic) - $I=f$

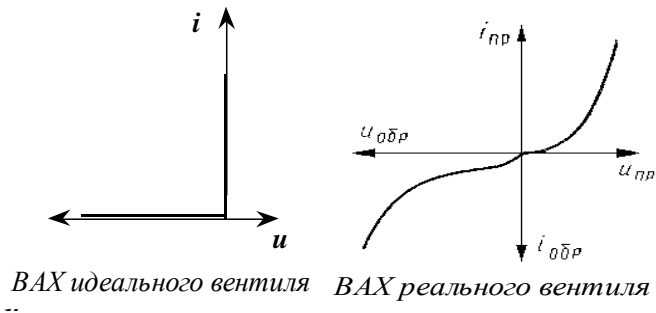

Fig. 10.3. Volt-ampere characteristics of a semiconductor diode

For an ideal valve, $R_{pr} = 0$, respectively, $U_{pr} = 0$, and the current I_{pr} is not limited, and $R_{ob} = \infty$, i.e. for any U_{ob} the value $I_{ob} = 0$.

The actual valve has some resistance R_{pr} , therefore, to create a given value of the forward

current I_{pr} , a definite value U_{pr} must be applied to it. And in the opposite direction, it has a finite R_{opp} , so it passes some reverse current I_{ob} (Figure 10.3). The valves are controllable and uncontrollable. At present, electronic semiconductor valves are mainly used: selenium, silicon, germanium (uncontrolled) and silicon controlled (thyristors).

Single-phase single-cycle rectification scheme

When there is a positive potential on the anode of the valve, the current will flow through the valve, R_n and close to the secondary winding of the transformer (Figure 10.4). If $U_2 = \sin\omega t$, then the current in the load will be in the form of a half-sinusoid, the same shape of the pulses will have a voltage on the load. This rectified current has a constant component I_0 representing the average value of the rectified current flowing through the period through the load.

In the single-cycle rectification scheme the following relationships hold:

$$U_0 = (\sqrt{2} / \pi) U_2 = 0,45 U_2;$$

$$I_0 = (2 / \pi) I_2 = I_2 / 1,57 = 0,637 I_2.$$

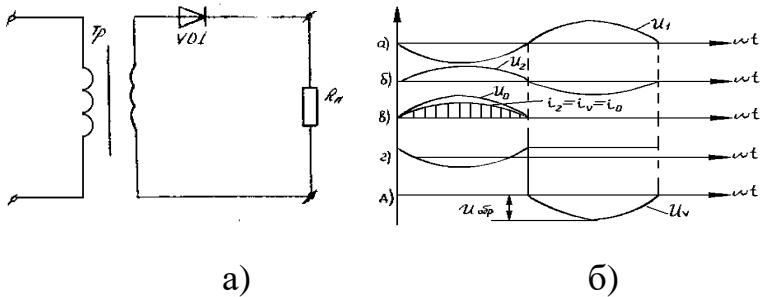

Fig. 10.4. Single-phase single-cycle rectification scheme (a) and time diagrams (b)

The reverse voltage applied to the closed valve is equal to the amplitude of the applied 2nd voltage of the transformer, i.e.

$U_{OBR} = U_m = \pi U_0 = 3,14 U_0 = U_2$, that is, 3 times the rectified voltage. The frequency of ripple of

the rectified voltage and current in such a scheme is $f_n = f_c$ (since $m = 1$).

Bridge rectification scheme

Otherwise it is called a single-phase bridge circuit Hertz. In it, during one half of the period, the rectified current flows through B1, RH, B3 and closes on the secondary winding of the transformer (Figure 10.5.).

With reverse polarity, the current will close through B2, RH, B4 and the secondary winding. That is, the current through the load and the secondary winding of the transformer flows throughout the entire period. The constant component of the current through R is equal to (assuming that $I_m = U_m / R_H$):

$$I_0 = \left(\frac{m}{\pi}\right) I_m \cdot \text{Sin} \frac{\pi}{m} = \frac{I_m}{\pi} = \frac{2\sqrt{2}U_2}{R_H \cdot \pi} = 0.9 \frac{U_2}{R_H};$$

$$U_0 = 2\sqrt{2} \frac{U_2}{\pi},$$

that is 2 times more than in a single-phase single-cycle circuit. Since the current in the secondary winding of the transformer flows throughout the entire period, its effective value is determined as

$$I_2 = \left(\frac{1}{2\pi}\right) \int (I_m)^2 \text{Sin}^2 \omega t d\omega t = I_m \frac{1}{\sqrt{2}}$$

$$I_0 = \left(\frac{2}{\pi}\right) \sqrt{2} I_2 = 0.9 \cdot I_2$$

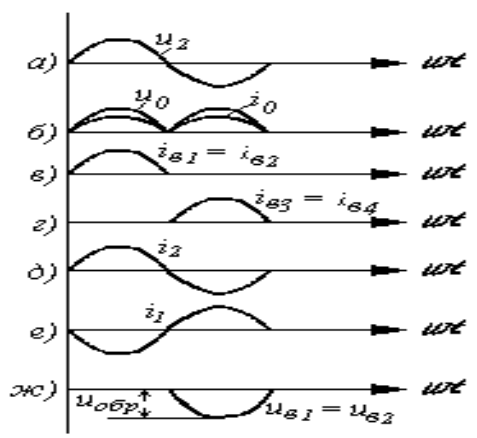
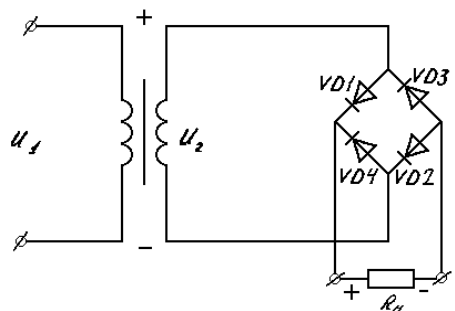

Fig. 10.5. Bridge rectification circuit (a) and time diagrams (b)

Since for each half-cycle two valves operate in pairs, the effective value of the current through each pair of series-connected valves is equal: $I_B = I_2 / 2$. For this circuit, $m = 2$, $f_P = 2 f_C$, the reverse voltage on the locked gates is defined as $U_{OBR} = U_m = U_2$, because The valves are connected to U_2 in parallel.

Two-cycle rectification scheme with zero output of the secondary circuit of the transformer

This scheme is also called a two-phase single-cycle circuit. for a period of rectified current, one current pulse flows in each half of the secondary winding of the transformer, but as usual two phase currents are not used in the AC technique because of the difficulties in generating it and the absence of two phase current networks, then the first name is often used (Figure 10.6.).

In this scheme, both halves of the secondary winding participate in the rectifier operation in turn. In the first half period, the rectified current circuit is closed through B1, RH and the semi winding of the transformer, in the second half period - through B2, RH and the other half winding of the transformer. The current flows through the load during the entire period with the same polarity. In this scheme, the constant component of the voltage on the load:

$$U_0 = \frac{m}{\pi} U_m \sin\left(\frac{\pi}{m}\right) = 2\sqrt{2} \frac{U_2}{\pi}$$

$$m=2, U_2=U'_2=U''_2,$$

$$I_0 = U_0 / R_H = 0,9 U_2 / R_H)$$

The effective value of the current of each half of the secondary winding of the transformer

$$I_2 = \frac{I_m}{2} \frac{2}{m} + \sin\left(\frac{2\pi}{m}\right) = \frac{I_m}{2} = 1.28 I_0$$

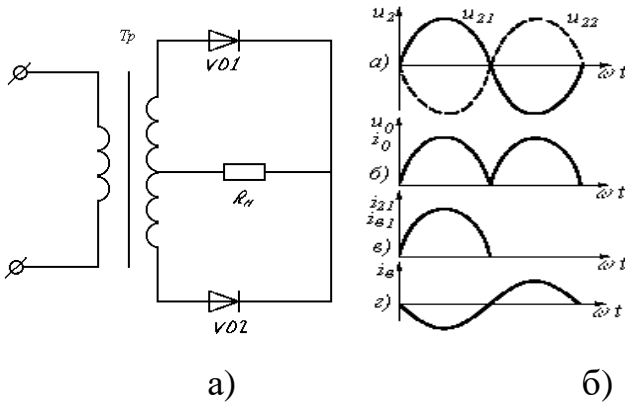

Fig. 11.7. Two-stroke rectification circuit with zero output of the secondary circuit of the transformer (a) and time diagrams of operation

The ripple frequency at the load is $f_n = 2 f_c$. The closed valve is under reverse voltage equal to the potential difference between the ends of the secondary winding of the transformer. The maximum value of this potential difference is equal to twice the amplitude value of the voltage on one half of the secondary winding, i.e.

$$U_{OEP} = 2U_m = 2\sqrt{2} U_2,$$

LECTURE 11. SMOOTHING FILTERS. MULTIPLE VOLTAGES.

Lecture plan:

11.1. Passive filters.

11.2. Active filters.

11.3. Voltage multipliers.

Filters

When studying various rectification schemes for alternating current, we were convinced that the instantaneous value of the rectified voltage is not constant, but is represented by a Fourier series containing a constant component and the sum of the harmonics of the variable components, of which the first harmonic whose frequency is $f_n = mfC$ is the largest. Then we determine the ripple of the rectified

voltage $K_{r_k} = \frac{2}{(km)^2 - 1} = \frac{U_r}{U_0}$, where k is the number of the harmonic.

The ripple coefficient can also be determined for the current $K_{PI} = I_{\sim} / I_0$. With a purely active load, $K_{PU} = K_{PI}$, and with a complex load $K_{PU} \neq K_{PI}$. Most often, the load makes it possible to have a pulsation coefficient of the supply voltage much less than that obtained at the output of the rectifier. Then, to reduce the pulsation, the output of the rectifier includes smoothing filters. The ability of a smoothing filter to reduce pulsation is estimated by a smoothing factor equal to the ratio of the ripple coefficient at the input of the filter (at the rectifier output) to the ripple coefficient at its output (on the load)

$$K_c = \frac{K_{\text{Пвх}}}{K_{\text{Пвых}}} = \frac{\frac{U_{01m}}{U_0}}{\frac{U_{H1m}}{U_H}},$$

where U_{01m} , U_{H1m} are the amplitudes of the main (first) harmonic of the variable component at the input and output of the filter; U_0 , U_H - constant components of the voltage at the input and output of the filter.

In addition to providing the necessary smoothing factor to the filters, a number of other requirements are also imposed. Since the whole load current passes through the filter, a part of the constant component of the current and voltage falls on it. To reduce this drop, the filter typically contains various combinations of reactive elements L and C, which have small active losses. Only at very low load powers the filter instead of L contains resistors. Requirements for filters:

1) the minimum drop in the DC component of the voltage;

2) must not distort the shape of the current in the load with a rapid change in load resistance R_H (due to the fact that the reactive elements of the filter prevent rapid changes in current and voltage);

3) absence of overvoltage and inrush currents in transients;

4) low cost, dimensions and weight;

5) high reliability;

6) the frequency of the natural oscillations of the filter must be less than the lower frequency of the variable component of the rectified voltage and current (otherwise there may be a resonance in the individual links of the filter, and the amplitude of the variable component will not decrease but increase).

There are various filter circuits: C, L, LC (L-shaped), CLC (U-shaped), multi-link LC and RC, resonant, electronic filters on transistors and microcircuits.

Passive filters

The methods for constructing smoothing filters on reactive elements are as follows:

in series in the load current circuit, an element having a large resistance to current changes and a small resistance for a constant current component (for example, a reactive core coil having an inductance L , a parallel resonance circuit) is connected and parallel to the load includes an element having a low

resistance for current variations and a large resistance for a constant component of the current (for example, a capacitor, a series resonant circuit). The principle of operation of these filters is based on the ability of reactive elements to accumulate and give off electrical energy.

The inductive filter consists of a throttle L , connected in series with the load R_H (Figure 11.1.). Smoothing action of the throttle is based on the occurrence in it of EMF of self-induction, which prevents changes in the variable component of the rectified current. The choke resistance $X_L = \omega PL$ for the constant current component is 0 (here $\omega P = 2\pi fP = 2\pi mfC = m\omega C$), and the alternating current component is not 0, and it produces a drop in the alternating voltage component. For better smoothing of pulsations, it is necessary that the inductive resistance of the throttle be much greater than the resistance of the load R_H (that is, $X_L = \omega PL \gg R_H$),

then the smoothing coefficient of such a filter

$$K_c = \frac{K_{\text{Итх}}}{K_{\text{Иотх}}} \approx \frac{\sqrt{R_H^2 + (m\omega_c L)^2}}{R_H} .$$

L-filters can be used in multiphase rectification circuits at high power and, with a small load resistance R_H , then the filter inductance is small, has small dimensions, and you can neglect the active losses in it. But it has drawbacks:

1) with a sharp change in the load current on the throttle, a large EMF of self-induction occurs, which creates an overvoltage on its winding, which is dangerous for insulation;

2) the smoothing action of this filter changes when the load current varies, since according to (3) the inductance of the throttle depends on R_H .

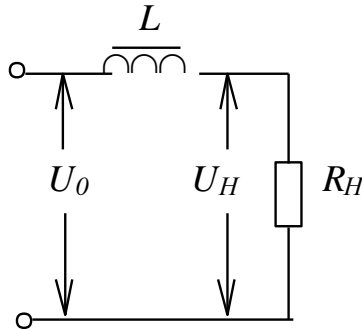

Fig. 11.1. Inductive filter

Advantages: simplicity, small power losses, small change in output U . The action of the capacitive filter is that when the rectifier voltage rises, it accumulates electrical energy, and when the voltage on the rectifier decreases, the accumulated energy on the capacitor is discharged to the load (Figure 13.2.). To ensure smoothing of pulsations, it is necessary that the capacitive capacitance of the capacitor is significantly less than the load resistance

$$X_C = 1 / (\omega_{CC}) \ll R_H, \quad K_c = \frac{2/(m^2 - 1)}{H/(r_\phi C)}$$

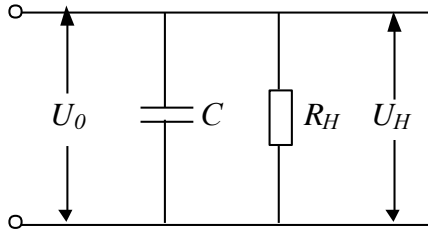

Fig. 13.2. Capacitive filter

If there is no capacity, the pulsation coefficient at the output of the rectifier K_P in $= 2 / (m_2 - 1)$

Then the smoothing coefficient of the C-filter

Its advantage is simplicity and small power losses. But he has a number of shortcomings:

1) the presence of a capacitive filter leads to an increase in the reverse voltage to the valve;

2) with a large load current, a large filter capacity is needed, otherwise the load voltage drops sharply with increasing load current due to the rapid discharge of the capacitor;

3) in multiphase rectification circuits, because of this filter, the cut-off angle sharply decreases, and phase failure may occur, that is, one of the rectifier valves will not conduct current;

4) since the charging current of the capacitor is large, and it passes through the rectifier, the cutoff angle of the valve current is greatly reduced in comparison with the case of the active load of the rectifier;

5) a large current amplitude passes through the rectifier valves, which is limited only by a small internal resistance of the rectifier.

Single-section L-shaped LC filter

Usually starts with an inductor and consists of a throttle and a capacitor and provides a much larger smoothing factor (Figure 13.3.). In this case, the condition that for the first harmonic $X_{C1} = 1 / (m\omega_{CC}) \ll R_N \ll \omega_{CL} = X_{L1}$, then together they are used much better than each of the filter elements separately.

If this condition is met, the total resistance of the circuit for the variable component of the rectified voltage is greatly reduced, so that the variable component of the rectified current through the choke increases, the voltage drop on it increases, so the variable component of the voltage at the load terminals decreases significantly (in comparison with its value when the L and C). In this case, neglecting the active resistance of the throttle, we can assume that $U_0 = U_H$, then the smoothing coefficient of the L-shaped filter is

$$C_S = U_{01m} / U_{H1m} = (m\omega_C) 2LC - 1.$$

if we take into account that $\omega_0 =$ is the natural frequency of the filter, then $K_C = (m\omega_C / \omega_0) 2 - 1$.

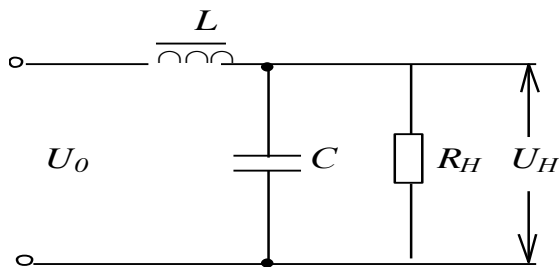

Fig. 11.3. Single-section L-shaped LC filter

Single-section II-shaped LC filter

A U-shaped LC filter can be represented as a two-part filter consisting of a capacitive filter C_0 and a T-shaped filter consisting of L and C_1 (Fig. 11.4). The smoothing action of such a filter can be represented as a joint action of both links, and its smoothing coefficient is equal to the product of the smoothing coefficients of both links, that is,

$PCR = KSS_0 KGS$, or, substituting here the values of KCC_0 and KG , we obtain:

$$K_{cII} = \frac{2r_{\phi}C_0}{H(m^2-1)} \cdot (L_1 C_1 m^2 \omega_c^2 - 1),$$

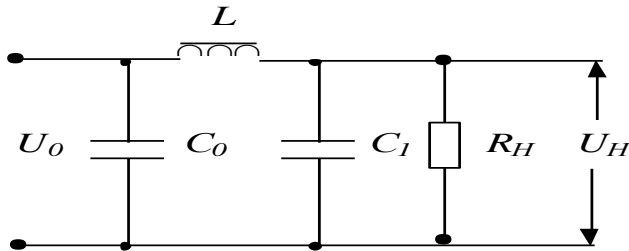

Fig. 11.4. Single-section II-shaped LC filter

Active Filters

Smoothing LC and RC filters have a number of drawbacks, the main ones are:

- 1) bulkiness and high cost of filter throttle;
- 2) the dependence of the smoothing factor on the load current;
- 3) the creation of an electromagnetic interference throttle;
- 4) occurrence of transients in filters;
- 5) the fact that slow oscillations and voltage changes are freely transferred to the load;
- 6) RC filters have a large voltage drop, a small smoothing ability, etc.

To ensure the smoothing action of the transistor, it is necessary to select its operating point A correctly so that the variable voltage component applied to the collector does not move the work point A beyond the sloping section of the characteristic, ie, I_k remains almost unchanged. In the simplest transistor filters,

the load is connected either to the emitter circuit or to the collector circuit (Figure 11.5.).

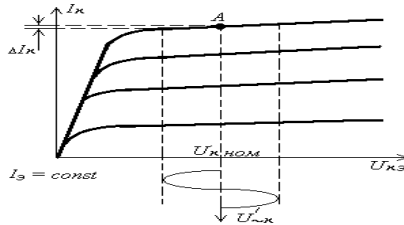

Fig. 11.5. Explanation of the smoothing action of electronic filters

In the filter, where the load is included in the collector circuit, its operation mode is determined by the time constant R_1C_1 - the chain (Figure 13.6.). This chain stabilizes the emitter current if its time constant is much longer than the ripple period of the input voltage.

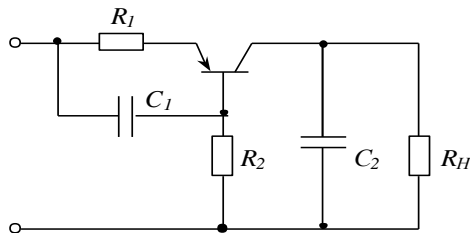

Fig. 13.6. Electronic filter circuit

Then the working point A under the influence of the input voltage pulsation will move along the gently sloping section of the collector characteristic (since the collector current I_k is almost independent of the collector potential, and basically is determined by the emitter current I_e , therefore, if $I_e = \text{const}$, any change in the input voltage only moves the point A right or left, almost without changing the value of the current I_k). Then the current I_k varies little, and the voltage at the load $U_H = I_{kRH}$ remains almost unchanged. A slight ripple at the output of the transistor will be smoothed by the capacitor C_2 . Resistance R_2 serves to set the preset mode.

1) the specified value of U_H is determined by the value of the reference voltage U_{et} , which is generated in the measuring element (IE) or is supplied from the outside;

2) regardless of the number and nature of the destabilizing factors affecting UN, stabilization is carried out only depending on the value of the value of UH itself;

3) the compensating stabilizer is a closed circuit of signal transmission.

The change in the output voltage ΔU_H goes to the input of the IE, from there the signal goes to the amplifying element (UE), and from the UE output the signal ΔU_u goes to the input regulating element (PЭ); here comes the resulted destabilizing stress arising from any destabilizing factor. A circuit consisting of measuring IE and UE is called the main feedback (OC), in contrast to the feedback circuits that can be in each functional element.

Voltage Multipliers

Voltage multipliers allow you to get the voltage at the output of the device, at any number of times the voltage at its input.

These devices have recently been increasingly used because they replace high-voltage transformers. With such a replacement, a noticeable gain in overall dimensions and mass is obtained, using the transformer, the values of these parameters are quite large, which is dictated by the need to provide the required electrical strength.

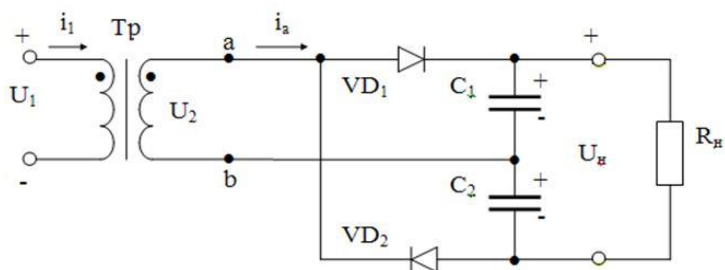

Fig. 11.7. Schematic of parallel voltage doubler

It consists of two half-wave rectifiers connected to one secondary winding of the transformer. In one of the half-periods of the input voltage, when point a has a positive potential and point b is negative, diode D1 is open, and diode D2 is closed. At this point in time, the capacitor C1 through the open diode D1 is

charged to the amplitude value of the voltage U_{2m} . In the next half-cycle of the input voltage, the potential of point b becomes positive, and the potential of point a is negative, diode D1 will close, and diode D2 - open. In this half-cycle through the open diode D2 the capacitor C2 is charged up to the amplitude value of the input voltage.

Capacitors C1 and C2 with respect to the output terminals are connected in series. The polarity of the voltages on the capacitors is such that the output voltage of the device is practically equal to twice the amplitude value of the voltage of the secondary winding of the transformer if the discharge time constant is $\tau_{cr} = CRH \gg T / 2$ (where $C = C1 = C2$, T is the period of the input voltage). Otherwise, the capacitors will be discharged in the following half-cycles after their charging and the output voltage will be less than $2U_{2m}$.

In Fig. 11.8. The circuit of a serial doubler of a voltage is shown. In one of the half-periods of the input voltage, when the potential of point b is positive, and the potential of point a is negative, diode D1 is open, and diode D2 is closed. At this point in time, the capacitor C1 is charged through the diode D1 to the amplitude value of the voltage U_{2m} . In the next half-period, the potential of point a becomes positive and the potential of point b is negative, diode D1 is closed, and diode D2 is open. The capacitor C2 then starts charging through diode D2, but from the voltage equal to the sum of the voltages of the secondary winding of the transformer U2 and the voltage of the previously charged capacitor C1. Therefore, the voltage across resistor R_n will be equal to twice the voltage value U_{2m} .

The series voltage doubler has a number of advantages over a parallel doubler: the ripple of the output voltage is less, and the stability of the work is

higher. In addition, of several consecutive doublers it is not difficult to assemble voltage detectors (Figure 11.9.), And by connecting two successors in series, it is possible to obtain an output voltage eight times the voltage applied to the input of the multiplier. For this reason, successive doublers are used more often than parallel ones.

With the help of voltage multipliers, a voltage of several tens of kilovolts can be obtained at the output, using small and inexpensive devices (capacitors and diodes) with low nominal voltages. Common drawbacks of all voltage multipliers are their low power and low efficiency.

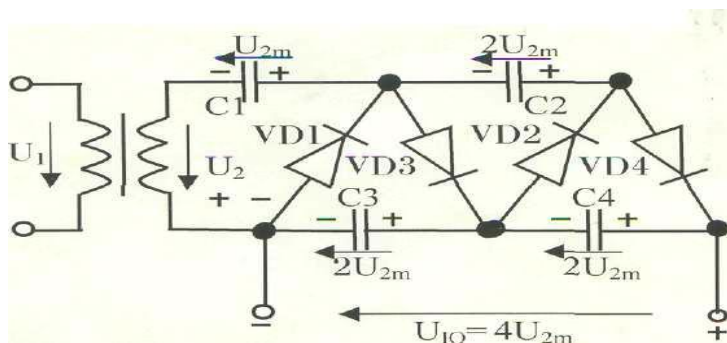

Fig. 11.9. Scheme of the voltage multiplier

At present, microelectronic technology has also affected the manufacture of voltage multipliers. The integrated circuits of the K299 series are manufactured and widely used, which allow to obtain an output voltage of 2000-2400 V at a current of $I_H \leq 200 \mu\text{A}$:

1. Advantages and disadvantages, application of a half-wave rectification scheme.

2. Advantages and disadvantages of the full-wave rectification scheme.

3. Application, advantages and disadvantages of bridge rectification scheme.

4. Features of voltage multipliers.

LECTURE 12. STABILIZERS

Lecture plan:

12.1. Stabilizer of voltage or current.

12.2. Parametric stabilizers.

12.3. Compensating voltage regulators.

Voltage and current stabilizers

A voltage (current) stabilizer is a device that automatically maintains the voltage (current) of the load device with a specified degree of accuracy.

Destabilizing factors:

- fluctuation of the mains voltage (from + 5% to - 15%)

- ambient temperature.

Classification of stabilizers on the basis of:

- by the nature of the stabilized value - the voltage and current stabilizers;

- by the method of stabilization - parametric and compensatory;

With the parametric method of stabilization, some devices with a nonlinear VAC having a gently sloping section are used, where the voltage is little dependent on destabilizing factors (zener diodes, barretters, incandescent lamps, transistors). With a compensating stabilization method, the constancy of the voltage is provided by automatically adjusting the input voltage of the power supply. This is achieved by introducing a negative feedback between the output and the regulating element, which changes its resistance so that it compensates for the resulting deviation of the output value.

Parametric Voltage Regulator

In parametric voltage stabilizers, the stabilization mode is carried out due to the nonlinearity of the current-voltage characteristic (VAC) of the regulating element. The quality of stabilization depends on the I-

V characteristic. In parametric voltage stabilizers, the elements whose IV characteristics are represented in Figure 12.1 are used.

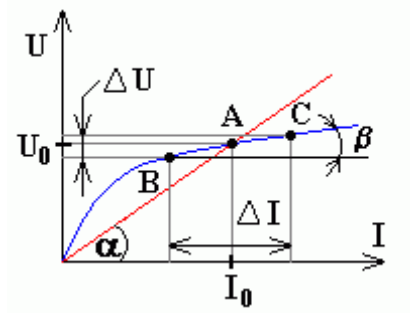

Fig. 12.1. Nonlinearity of the current-voltage characteristic (I-V characteristic)

The degree of nonlinearity of the I-V characteristic in the working section of the aircraft is estimated by the ratio of the dynamic and static resistances.

The static resistance of RC is the resistance that a nonlinear element exerts on a constant current in the selected operating point A of the characteristic:

$$R_S = U_0 / I_0 = \operatorname{tga}.$$

The dynamic resistance of the element R_D is equal to the ratio of the change in the voltage drop across the element DU to the change in the magnitude of the current flowing through the DI element. The dynamic resistance is the resistance that the element exerts by changing the current flowing through it:

$$R_D = DU / DI = \text{tgb.}$$

Static and dynamic resistances are not equal to each other and vary depending on the magnitude of voltage and current: $R_D < R_C < R_C > R_D$.

Gas-discharge and silicon zener diodes are used as nonlinear elements in parametric voltage stabilizers. The schemes of parametric stabilizers using zener diodes are used to stabilize the voltage at a power in the load up to several watts. The advantage of such schemes is simplicity of execution and a small number of elements, a disadvantage is the absence of smooth adjustment and exact setting of the nominal

value of the output voltage, in addition, such schemes have small efficiency.

The stabilizer circuit consists of a quenching resistor R_G , connected in series with the load, and a zener diode VD , connected in parallel with the load (Fig. 12.2.).

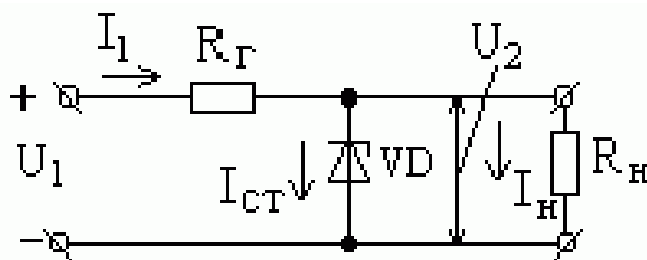

Fig.12.2. The stabilizer circuit consists of a quenching resistance R_G

Let's consider the operation principle of this stabilizer.

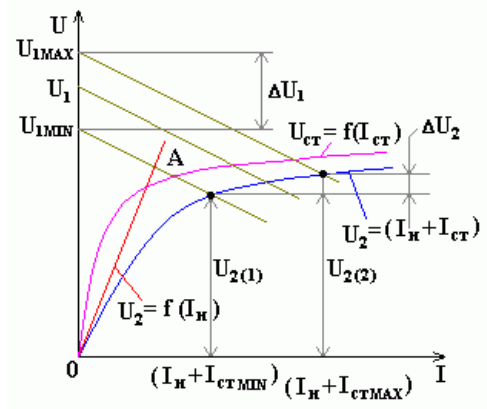

Fig.12.3.VA Zener diode and load

The figure shows the current-voltage characteristics of the zener diode and the load (Fig. 12.3.). Since the load resistance and zener diode are connected in parallel, to build the total characteristic it is necessary to combine the characteristics of the resistance R_H (straight line OA) and the zener diode VD along the current axis. The resulting curve represents the dependence $U_2 = f(I_H + I_{CT})$. The working section of this curve is obtained by shifting the zener diode characteristic by the value of the load current I_H . Having set the input voltage U_0 on the

ordinate axis, we build the resistance characteristic R_G from this point.

The point of intersection of this characteristic with the total characteristic of the load resistance and zener diode determines the steady-state mode for a given value of the input voltage. When the input voltage changes, the resistance characteristic R_G is moved and accordingly the working point moves on the total characteristic $U_2 = f(I_N + I_{ST})$.

As can be seen from the figure, when the input voltage varies from U_{1MIN} to U_{1MAX} , the voltage across the load resistance changes from $U_2(1)$ to $U_2(2)$, and the change in the output voltage ΔU_2 is significantly less than the change in the voltage at the input ΔU_1 .

To determine the main quality indicators of a parametric stabilizer of a constant voltage, let's imagine it as a functional circuit for changes in the voltage at the input (Fig. 12.4.).

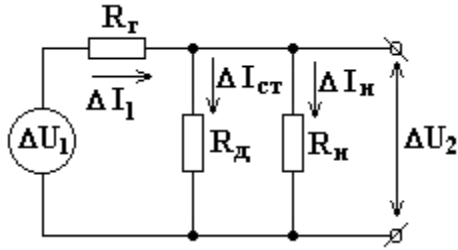

Fig. 12.4. Functional diagram for changes in input voltage

Assuming that the stabilizer is loaded on the active resistance R_H , the change in ΔU_1 is slow and the differential resistance of the zener diode is invariably within the operating range of the zener diode. Then, the transfer function connecting the disturbance at the input ΔU_1 with the reaction at the output ΔU_2 is represented by the fission coefficient

$$K_{\mathcal{D}} = 1 / \left(1 + \frac{R_{\Gamma}}{R_{\mathcal{D}}} + \frac{R_{\Gamma}}{R_H} \right). \quad (2)$$

From (1) we define

$$\frac{\Delta U_1}{\Delta U_2} = \frac{1}{K_{\mathcal{D}}} = 1 + \frac{R_{\Gamma}}{R_{\mathcal{D}}} + \frac{R_{\Gamma}}{R_H}. \quad (3)$$

The ratio DU_1/DU_2 is the differential stabilization factor KST.D., which is related to the stabilization coefficient KST.U by expression (4) where $K_0 = U_2 / U_1$ is the transmission coefficient of the constant component of the stabilizer voltage.

Compensating voltage regulators

Compensating voltage regulators, depending on the location of the regulating element (RE), are divided into stabilizers with sequential and parallel inclusion of the RE. Figure 12.5. The functional diagram of a voltage regulator with a serial RE is presented.

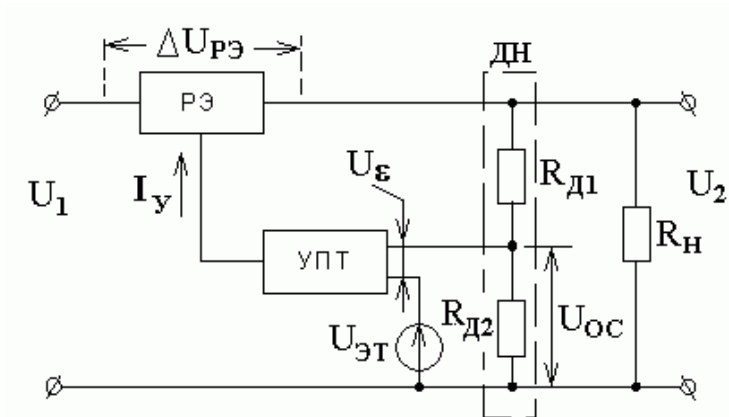

Fig.14.5. Functional diagram of a voltage regulator with a serial RE

The power circuit of the stabilizer is a regulating element (RE) and a load (RH). Due to the change in the voltage drop across the RE, the voltage is constant at the load U_2 . The negative feedback voltage (OOS) circuit includes: voltage divider (DC), direct current amplifier (DCT), reference voltage source (UET). The feedback voltage (UOS) is taken from the lower arm of the DC (RD2) and fed to the input of the UPT, where a comparison of the UOS and UET occurs. In the UPT, the difference voltage (error signal $U_e = U_{OC} - U_{ET}$) is amplified, which leads to a change in the control current (IV) and the change in the voltage drop across the RE (DURE).

The output voltage (U_2) is then restored to its original value. For example, if the voltage at the input (U_1) increases or the load current decreases, the error

signal (U_e) increases, the control current decreases (I_U) and the voltage increases on the RE and the voltage restores on the load. The circuit has a higher efficiency compared to a voltage regulator with a parallel RE. The disadvantage of the scheme is low reliability due to possible overloads of the current in the current.

As the input voltage U_1 increases, the initial time increases the voltage on the load U_2 and, consequently, U_{OC} . The latter leads to an increase in the error voltage U_e , the control current I_W and the current consumption I_1 . In this case, the voltage drop across the ballast resistor DUR_{Bi} increases, the voltage in the load is restored, i.e. decreases.

Consider the functional diagram of the voltage regulator with parallel RE (Fig. 12.6.):

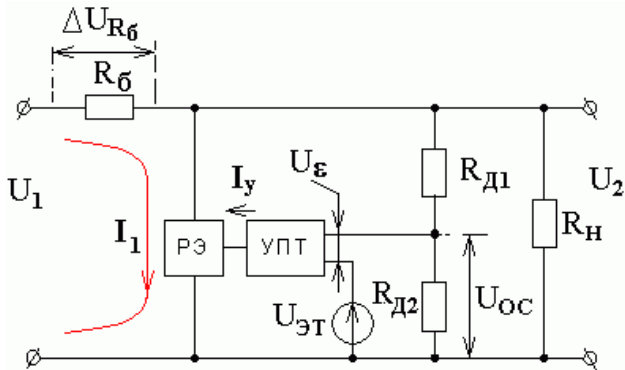

Fig. 12.6. Functional diagram of voltage regulator with parallel RE

The circuit has a low efficiency due to losses on the ballast resistor R_b , but higher reliability, because since the power transistor is switched on in parallel with respect to the load and is not exposed to short circuits. Schematic diagram of the compensation voltage regulator

See Figure 12.7. the principal diagram of the compensating stabilizer of continuous action with a serial RE is presented. The regulating element is made on the transistor VT1, the VTT on the transistor is

increase in the I_{K2} current. According to Kirchhoff's law for the node:

$I_1 = I_1 - I_{K2}$, so the base current of the transistor VT1 decreases and the transistor closes. Voltage drop DU_{KE1} is increased, and the load voltage is restored.

Consider the movement of the operating point on the output characteristics of the transistor (RE) with increasing input voltage (Fig. 14.8.). In this case, the load line moves parallel to the right with respect to the load line for the nominal level U_{1nom} .

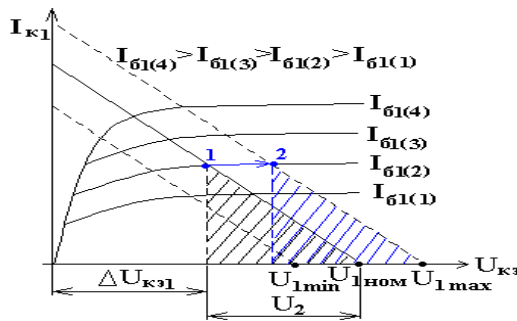

Fig. 14.8. Moving the operating point on the output characteristics of the transistor (RE) with increasing input voltage

As the voltage U_1 increases, the leg of the rectangular triangle U_2 remains constant, the voltage drop $DUKE1 = U_1 - U_2$ changes. The operating point moves from position "1" to "2". Consider the principle of the action of the compensating stabilizer when the load current changes (Fig. 12.9.).

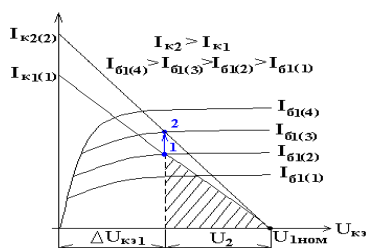

Fig.12.9. The operating principle of the compensating stabilizer with a change in the load current

As the load current increases, the current consumed from the source $IK1$ increases, which leads to an increase in the voltage drop on the RE-DUKE1 and a decrease in the voltage on the load. The operating point moves from position "1" to "2" and

the transistor VT1 opens slightly due to the increase of the base current. Voltage on the load is restored.

LECTURE 13. CONVERTERS

Lecture plan:

13.1. Voltage converters.

13.2. Two-cycle converters with independent excitation.

13.3. Thyristor converters.

Voltage converters

To supply the communication equipment, different values of the constants and the variable voltages are required. If there is an electric power source that generates DC power of one voltage (battery, rectifier, etc.), then for the supply of communication equipment with different voltage ratings, special devices are used that convert a single-

voltage DC voltage into alternating and direct-current alternating current.

These devices are called DC-to-DC converters. They convert the energy of a direct current into the energy of an alternating current, which can again be rectified. Converters that convert DC power into AC power are called inverters. If we put the rectifier on the output of the inverter, then we get a converter with an output at a constant current, it is called a converter.

At present, mainly semiconductor converters are used, which are made on transistors or on thyristors. Their main part is inverters. They are single-cycle and two-stroke, with self-excitation or with independent excitation (with power amplification). There are current and voltage inverters.

Thyristor inverters are classified by the principle of switching thyristors: autonomous or driven by the network, by switching the switched capacitance relative to the load - parallel, serial and series-parallel.

Transistor inverters are classified: by the way of switching on the transistors - with a common emitter or with a common collector, by feedback type - with the OS by voltage, with AC current, with the OS by voltage and current. One of the components of the inverter is a transformer, which creates an alternating voltage and converts its value. Since a constant voltage is applied to the input of the transformer, for its normal functioning in its primary circuit, a device periodically disconnecting and closing the DC circuit - a switch, a current interrupter is needed.

e interruption of the current or the change in the direction of this current causes the magnetic flux $\Phi(t)$ to appear in the magnetic circuit of the transformer, which, according to the law of electromagnetic induction, induces in the windings of the transformer EMF, the value of which is proportional to the rate of change of the magnetic flux and the number of turns of the windings. Structural diagram of a single-cycle

converter with self-excitation The block diagram of a single-cycle converter is shown in Fig. 13.1.

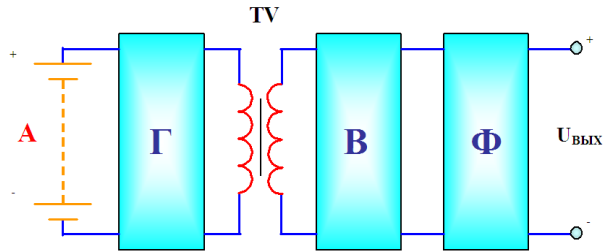

Fig. 13.1. Structural diagram of a single-cycle converter with self-excitation: A - battery, Г - generator, B - rectifier, Φ - filter.

The source of direct current is the battery B, which has a small voltage U_{BX} , which is supplied to the input of the transformer T_p intended for forming the AC voltage and converting its value. Since the battery voltage is constant, for the normal operation of the transformer in its primary winding it is necessary to switch on the current breaker, periodically with a frequency of 350 ... 400 Hz, the closing and breaking

The breaker is the key K, which periodically closes and opens, respectively, in the transformer core, the magnetic flux then increases, then decreases, creating a variable EMF on the secondary winding. As a key K you can use any electronic and electromagnetic devices. Such converters at the current stage allow obtaining an alternating voltage of $30 \div 50$ Hz at the output. Therefore, they are rarely used.

Push-pull converters with independent excitation

Let's consider an example of a push-pull converter on transistors with self-excitation and transformer feedback. To do this, we use transistors, included in the scheme with a common emitter, the circuit of which is shown in Fig. 13.1. This PPN is a relaxed voltage generator of rectangular shape with negative voltage feedback. In it, the core of the transformer is made of a material with a rectangular

hysteresis loop (PPG), and the transistors T1 and T2 operate in a key mode. Due to the spread of the parameters of the transistors T1 and T2 at the instant of power supply U_0 , one of them will be more open than the other.

Let T1 be more open, then a larger collector current will pass through it than through T2. The primary winding of the transformer has an average point 0 connected to the emitters of both transistors. The input voltage U_0 is applied between the common point of the emitters and the middle point of the primary winding of the transformer. The currents along the floor to the windings a_0 and a always flow in opposite directions. If $I_{K1} > I_{K2}$, then the current through a_0 will be larger than the winding around the winding. A magnetic flux appears in the core of the transformer, the direction of which is determined by the current I_{K1} , this flux generates in the secondary

winding and in the feedback winding of the EMF transformer.

When a voltage U_0 is applied to the inverter input, a negative bias voltage is applied to the base of the transistors through the voltage divider R_b , R_n , thereby opening them. The polarity of the electromotive force in the UC due to the current I_{K1} is chosen so that in the winding b_2 there is a plus at point c and minus at point r , then T_1 will open even more, and T_2 will close, i.e. I_{K1} increases, and I_{K2} decreases, hence the magnetic flux in the transformer core increases. When the core is saturated, $dF / dt = 0$, i.e. EMF in the winding W_{OC} and W_2 will stop hovering. In the W_{OS} , due to the EMF, the self-inductance (+) at the point b will begin to decrease, and (-) at the point r will also decrease, i.e. T_1 will close, and T_2 will open, then I_{K2} will be larger than I_{K1} , and the transformer core will begin to magnetize, i.e. will appear dF / dt , in

As a result, IOC and W2 will change their sign, and T2 will open even more, and T1 will close even more. This will continue again until the core saturates. As a result, an alternating voltage of almost rectangular shape is formed at the output of W2. In this scheme, the key mode of the transistors is specified using a rectangular hysteresis loop. Condenser C is needed to increase the steepness of the rise of half-waves of collector currents IK1 and IK2. (Fig.13.2.)

Such inverters are used at small capacities (up to 50 W).

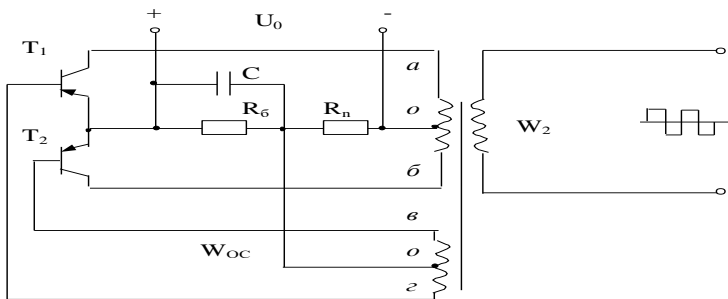

Fig. 13.2. Scheme of push-pull converter on transistors with self-excitation and transformer feedback

At high power, inverters with independent excitation (with power amplification) are used, the circuit of which is shown in Fig. 13.3. In this circuit, via the $Tp2$, the control signal is applied to the emitter-base junction of the transistors $T1$ and $T2$, with a predetermined frequency. $T1$ and $T2$ alternately open, creating currents of different directions $IK1$ and $IK2$ in the primary windings of the transformer $Tp1$. As a result, an alternating voltage is generated at the output of $W2$, the shape of which is given by the shape of the hysteresis loop of the core $Tp1$.

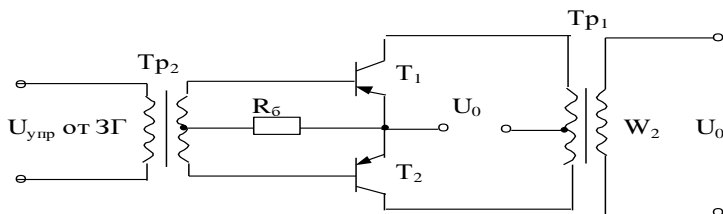

Fig. 13.3. Схема инвертора с независимым возбуждением (с усилением мощности)

Thyristor converters

Converters on thyristors are made at high load power. Thyristors have two stable states and are available for voltages up to several kilovolts and currents up to hundreds of amperes. In network-driven inverters, switching of thyristors is provided by a network of alternating voltage, on which the inverter operates. In autonomous inverters, the thyristor switching frequency is ensured by the frequency of the thyristor control system. Consider, for example, a push-pull autonomous transducer on thyristors with an average point (Figure 13.4.).

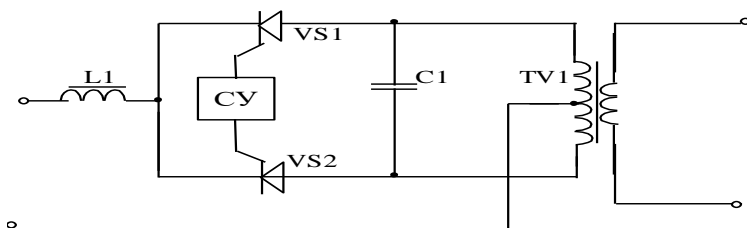

Fig. 13.4. Scheme of voltage converter on thyristors

To open the thyristor, a signal is needed from the control circuit (SS), which represents the pulse generator supplied with a shift of 180° to the control electrodes of the thyristors T1 and T2, ensuring that they are opened one by one. To lock the thyristors is a switching capacitor CK, connected in parallel with respect to the load. The transformer Tp in the thyristor inverter must operate in the linear region of the magnetization curve of the core. Suppose first the signal for opening T1 came from the SS, then the input voltage U_0 is applied to the primary winding a_0 of the transformer Tp (-) at the point a and (+) at the point o through the open T1, a magnetic flux is created in the transformer core, transformer creates a magnetic flux that induces in the primary half of the winding EMF mutual inductance, equal in magnitude

to U_0 and with polarity (+) at the point o and (-) at point c. As a result, the switching capacitor CK is charged to a voltage of $2U_0$. In the secondary winding T_p , the EMF E_2 is also induced. The next moment from the SS circuit comes a signal to open T2, as a result, both thyristors turn out to be open, and the capacitor of the SC is discharged through the open T2 on T1 and closes it. At this time, all of U_0 is applied to the semiconductor winding with polarity (+) on a and (-) on c.

In the semi-winding a_0 , an EMF is induced with polarity (+) by a, (-) by o, the capacitor is recharged to $U_C = 2U_0$ with the reverse polarity. At the output of the transformer at this time, an EMF pulse of opposite polarity is formed. At the beginning of the third half of the period, T1 is again opened and the capacitor SC is turned on through it in parallel with T2 and closes T2. In the future, the process is repeated. In this

scheme, the voltage U_2 varies exponentially (Figure 13.5.).

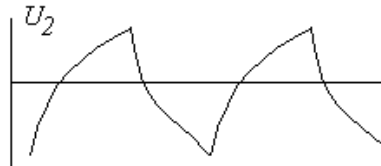

Fig. 13.5. Form of voltage on the secondary winding of a power transformer

The condition for the stable operation of the thyristor inverter is reliable locking of the previously operating thyristor. For a reliable shutdown, it is necessary that the decrease in the current through the thyristor decreases from I_{max} to 0, which is sufficient to completely restore the blocking properties of the thyristor. This time is called the recovery time of the thyristor.

For this, the capacitance of the capacitor must be sufficient to satisfy the condition $t_v > 2t_{top}$ of the addr, where t is omitted. - Allowable turn-off time of the

thyristor (given in the manuals). The disadvantage of such inverters is that the voltage at its output is strongly dependent on the load current due to the fact that when the ZH is decreased, the constant of the capacitor's recharge time varies greatly.

LECTURE 14. SOURCES OF UNINTERRUPTED FEED

Lecture plan:

14.1. The main types of UPS.

14.2. UPS functions.

14.3. Main specifications of uninterruptible power supplies.

14.4. UPS batteries.

Uninterruptible power supplies are designed to provide power to the computer for any network disturbances up to the complete disappearance of the voltage.

Main Types of UPS

There are three basic types of UPS: Stand-By (or Off-Line). Line-Interactive and Online. They will be discussed below.

UPS type Stand-By

In the network mode of UPS, this type of power supplies the computer through a branch containing only a mains filter, while simultaneously recharging the batteries. If the mains voltage deviates from the permissible value, UPS uses a special electronic switch to transfer the PC to battery power (the inverter converts DC to AC). The switching time is usually 3-5 ms. That, given that almost all modern equipment power supplies are impulse, that's enough.

Among the advantages of uninterruptible power supplies of this type is simplicity, cheapness, minimum dimensions and weight. But the disadvantages are much greater: because of attempts to reduce the price of UPS of this type when working on batteries, not all models have sinusoidal voltage (trapezoidal, etc.), the source does not protect against all types of interference and the like.

UPS type Line-Interactive

Essentially, these UPSs are an improvement of the UPS off-line type. In such sources, the inverter is continuously connected to the output, thereby providing galvanic isolation. In addition, power supplies of this type are also equipped with a transformer (stabilizer), which smooths out the power surges, resulting in UPS switching to battery power. UPS Line-Interactive is usually equipped with a better quality, than the offline sources, the network filter.

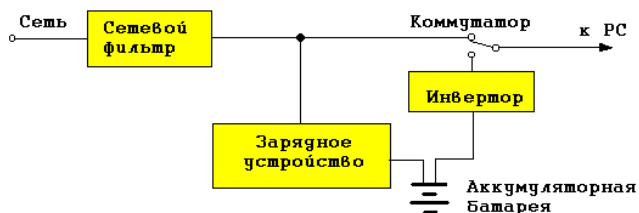

Fig. 14.1. UPS type Stand-By

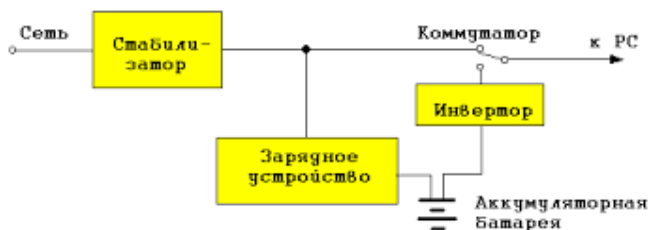

Fig.14.2. UPS type Line-Interactive

Advantages of Line-Interactive sources are rather high reliability, optimal price / quality ratio. The disadvantage is that protection is not against all interference.

UPS type On-Line

Sources of this type are also often called double-conversion sources. In them, the input voltage is converted into a constant voltage by a rectifier and fed to a high-frequency converter. From the output of the high-frequency converter, the voltage is applied to the inverter and from it to the output of the device. The need for a converter is due to the fact. that significant changes in the voltage in the network are converted into relatively small changes in the high-frequency signal at the output (the electronics of the PC are more sensitive to

change the level of the supply voltage, than to its frequency). In the event of a voltage failure beyond

the permitted limits, the inverter starts to feed the computer from the batteries without any switching operations. This ensures a high stability of the parameters, the output current.



Fig. 14.3. UPS type On-Line

UPS Online is used when extremely reliable protection (servers, medical equipment, etc.) of electronics is needed. Advantages: very high reliability, full protection against all power shortages. Disadvantages: high price, because of the dual conversion of low efficiency compared to the UPS type StandBy and Line-Interactive.

UPS Functions

Main functions of the UPS:

- Absorption of relatively small and short-circuited discharge voltages;
- Filtering the supply voltage, reducing the noise level;
- Provision of redundant power supply for a period of time after the mains voltage is disrupted;
- Protection against overload and short circuit.

In addition, many UPS models under the control of specialized software can perform the following functions:

- ♣ Automatic shutdown of the serviced equipment with the continued absence of voltage in the network, as well as the restart of the equipment when restoring the mains supply;

- ♣ Monitoring and recording in the log-file the status of the power source (temperature, level of charge of batteries and other parameters);

- ♣ Display of the voltage level and frequency of the alternating current in the power supply system, the

output power supply and the power consumed by the load;

- ♣ Tracing of emergency situations and issuing warning signals (sound signals, launch of external programs, etc.);

- ♣ Turn on and off the load on the internal timer at the specified time.

Main specifications of uninterruptible power supplies

Form of supply voltage. Important is the load characteristic of this uninterruptible power supply. In the UPS operation mode from batteries, the load can receive an output AC voltage close to the rectangular shape (meander), due to the smoothing properties of the filters, an approximated sinusoid and a pure sine wave. The form of the output voltage closest to the sinusoid is obtained by applying pulse-width modulation.

Getting a sinusoid as a supply voltage is typical only for On-line UPS and some Line-Interactive power supplies.

Power Full or output power. Indicated by the letter S, unit of measure - VA or Volt-Amperes. It is the geometric sum of active and reactive power. The parameter is calculated as the product of the acting (rms) current and voltage values. Its value is indicated by the manufacturer of the power source.

Active power consumption. Denoted by the letter P, the unit of measure is Watt (W). In the absence of a reactive component in the network, it coincides with the total power. It is defined as the product of the total power by the cosine of the angle φ , where φ is the angle of phase shift of the voltage and current vectors, i.e. $P = S \cdot \cos(\varphi)$. Typical value of $\cos(\varphi)$ for personal computers is about 0,6-0,7. This value is called the power factor. Obviously, to select the required power for an uninterruptible power supply,

the load power in watts should be divided by the value $\cos(\varphi)$.

Reactive - is denoted by the letter Q and is calculated as the product of the total power S by the sine of the angle φ ($Q = S \cdot \sin(\varphi)$). Unit of measurement - volt-ampere reactive (var). Characterizes the losses in the supply wires due to the reactive current charging them. At $\cos(\varphi) = 1$, there are no losses, all the power generated by the power supply goes to the load. This is achieved by using passive compensating devices or by an active power factor correction.

Input voltage range. Input voltage range - defines the limits of permissible network voltages at which the uninterruptible power supply is still able to maintain the output voltage without switching to battery power. For some models, this range depends on the load. For example, at 100% load, the input voltage range can be 15-20% of the rated voltage, at

50% load - this range is 20-27% of the nominal voltage, and at 30% load - 40% of the nominal voltage. This parameter depends on the battery life, the wider the range, the longer the batteries last longer, all other things being equal.

Frequency of input voltage. Frequency of input voltage (input frequency) - characterizes the range of deviation of the frequency of the mains. Under normal operating conditions, the frequency deviation from the nominal value does not generally exceed 1 Hz. The distortion factor of the shape of the output voltage The total harmonic distortion (THD) distortion factor characterizes the deviation of the shape of the output voltage from the sinusoid, measured in percent. The small values of the coefficient correspond to the form of the output voltage approaching the sinusoidal.

Time switch modes. Time transfer mode (transfer time) characterizes the inertia of the

uninterruptible power supply, for different sources is approximately up to 2-15 ms.

Permissible load. The over load characterizes the stability of an uninterruptible power supply in case of overloads in power, measured in percent relative to the rated power. Determines the stability of the UPS to non-stationary overloads.

Battery life. The battery life is determined by the capacity of the battery and the size of the load. For typical uninterruptible power supplies of small power, feeding personal computers, it is 5-10 minutes. This time is calculated so that the user can close all running applications with saving information and turn off the PC in normal mode.

Battery Life. The service life of the batteries is 4-5 years, but the real one depends very much on the operating conditions: the frequency of switching to the autonomous mode, charging conditions, the environment.

Availability of cold start. The presence of a cold start is the possibility of switching on an uninterruptible power supply in the absence of voltage in the supply network. This function is useful when it is necessary to immediately perform any actions, regardless of the presence of voltage in the electrical network.

Batteries UPS The source, the energy of which is used to power the load in critical operating modes, is a rechargeable battery. Uninterruptible power supplies up to 20 kW typically use sealed lead-calcium batteries with electrolyte of suspension type. In batteries of this type, the electrolyte is immobilized, either with silica gel or with a skeleton fiber, which makes them leak-proof. This property of the electrolyte allows you to operate the batteries in any position, in addition, they do not need periodic replenishment of the electrolyte and other maintenance.

The electrodes are made of lead-calcium alloy, which provides a long service life and a wide range of applications of batteries, the operating temperature range is from -20 to +50 ° C (for some types of batteries). Batteries do not suffer from the so-called "memory effect", they can be stored for a long time in a charged state (up to a year), while the self-discharge current is insignificant.

Selecting an uninterruptible power supply

The range of types of uninterruptible power supplies, as a means of protecting equipment and computer systems, is quite wide. The choice of the required power source is very difficult. To solve the issue of choosing a particular UPS, you should try to analyze the factors affecting the operating conditions of the power source.

First, we must try to assess the importance of the system being fed. It is possible that for a home or office version there will be enough uninterruptible

power supply Off-line or Line-interactive type. On-line UPS is more suitable for a server computer and other types of load, which have increased requirements for quality and reliability of power supply. Secondly, it is necessary to evaluate the quality of the power network: the probability and frequency of the power failure, the presence of voltage fluctuations and various interference.

Thirdly, it is necessary to estimate the power of an uninterruptible power supply. In order to roughly estimate the power of the UPS, it is necessary to determine the protected equipment and calculate the total value of the consumed power for it. Then, the obtained watts must be transferred to the VA, dividing by the power factor. For computer equipment, the power factor is 0.5-0.6.

LECTURE 15. SYSTEMS OF ACCOUNTING AND CONTROL OF ENERGY CONSUMPTION (ASKUE)

Lecture plan:

15.1. Modern complex systems of electricity control and accounting.

15.2. The concept of ASKUE.

15.3. Commercial and technical AMR.

Modern integrated systems for monitoring and accounting of electricity

Automated objects of power supply systems include:

- line grid and distribution facilities of electric power complexes
- power supply systems for enterprises distributed power consumers' networks.

For these objects, it is proposed to create (modernize) and implement the following automation systems for monitoring and accounting processes:

- ASKOUE - automated systems for monitoring and operational accounting of electricity
- ASDAE - automated systems for dispatching and operational accounting of electric power
- ASKUE - automated systems for commercial electricity accounting.

ASKOUE systems are designed for operative monitoring of the status and modes of the power supply and technical accounting of power consumption in the power supply systems of enterprises. ASDAE systems are designed for operational monitoring of the status and modes of the power supply and technical accounting of power consumption and dispatching control in power supply systems.

ASKUE systems are designed to automate the information support of accounting operations of settlement procedures (processes) for consumed electricity between the supplier and the consumer.

The functions of AMR include the following:

- centralized operational control of energy supply and energy consumption processes

- the current state of the working circuit (the state of the switching equipment of the main power supply circuit), the current values of the main parameters of the power consumption (load current, voltage, power, $\cos \varphi$, etc.) and the states of the protection devices and local automation

- warning and alarm signaling

- monitoring of energy supply and energy consumption processes

- monitoring and archiving the results of monitoring the status of the working scheme and measuring the parameters of energy consumption

- monitoring and archiving of the results of monitoring the operation (operation) of protection devices and local automation

- Tracking and archiving operations of operational and managerial personnel

- automation of reporting documents

- providing specialists with tools for analyzing energy supply and energy consumption processes - graphical visualization, automated procedures for finding extreme values and critical situations, etc.

- accounting of consumed electricity (active / reactive) by inputs and connections / consumers, for AMRMS - commercial accounting in accordance with the market status of the system

- formation of balances for the sections and sections of control and accounting

- calculations of technical and economic indicators

- time synchronization

- Information and physical protection against unauthorized access to system resources and self-diagnostics.

Basic principles of building AMR

- Measurements based on digital processing methods.

- Digital interfaces for the transmission of measured parameters.

- Deep archiving of the basic measurements in the meter.

- Control of the reliability and completeness of data at all levels of the system.

- Diagnosis of system health.

- Redundancy of communication channels.

- Parallel synchronous-asynchronous data processing.

- Hierarchical construction of the system.

- Possibility of distributed data processing.

- Protection of information at all system levels.

- Use of proven and standard components of the system and tools.
- Parallel data collection.
- Scalability and scalability.
- Management of system availability at the design stage.
- The system is built from typical approved subsystems, combined into the necessary structure.

The main task of ASCME is to accurately and quickly measure the amount of energy and power consumed and transmitted, to ensure that these measurements can be stored for any period and access to these data to settle with the supplier or consumer. Moreover, all actions are possible, taking into account daily, zone and other tariffs. In addition, an important component is the possibility of analyzing the consumption (transmission) of energy and power. The introduction of integrated systems for commercial accounting of energy resources allows you to quickly

obtain data on energy consumption, provides a constant saving of energy resources and financial costs, and also helps to significantly reduce the labor costs of collecting, transmitting, documenting information, reducing technical losses of electric power, providing operational control of the execution of the dispatch schedule of the loads. Thus, the main goal of introducing AMRMS is to reduce technical and commercial losses of energy resources by increasing the accuracy and reliability of energy resource accounting, reducing the time of collection and processing of data. ASKUE allows for precise analysis and planning of energy consumption, including the possibility of using the tariff and supplier that is optimal for a given period of time.

The concept of AMR

Solving the problems of energy accounting at the enterprise requires the creation of automated systems for the control and accounting of energy resources

(ASKUE), in the structure of which, in general, there are four levels:

- the first level - primary measuring devices (PID) with telemetric or digital outputs, carrying out continuously or with a minimum averaging interval the measurement of the parameters of the consumers' energy account (consumption of electricity, power, pressure, temperature, amount of energy, quantity of heat with energy carrier) at the accounting points (feeder, pipe, etc.);

- second level - data acquisition and preparation devices, specialized measuring systems or multifunctional programmable converters with built-in energy accounting software that perform a round-the-clock gathering of measurement data from geographically distributed PIPs in a given cycle of averaging, accumulation, processing and transfer of this data to the upper levels;

- the third level - a personal computer (PC) or a data center server with specialized software AMRMS, which collects information from the DRC (or group of the USPD), the final processing of this information by both accounting points and by their groups - by units and objects of the enterprise, documenting and displaying accounting data in a form convenient for analysis and decision making (management) by the operational staff of the main power engineering service and the company management;

- The fourth level is the server of the data collection and processing center with the specialized software AMRM, which collects information from a PC and / or a group of servers of data collection and processing centers of the third level, additional aggregation and structuring of information by groups of accounting objects, documentation and display of accounting data in a form convenient for analysis and decision-making by the personnel of the main power

engineering service and the management of territorially distributed medium and large enterprises or power systems, No contracts for the supply of energy resources and the formation of payment documents for settlements for energy resources.

All levels of AMR are connected by communication channels.

Commercial and technical AMR

By designation ASKUE enterprises are divided into systems of commercial and technical accounting.

Commercial or settlement accounting refers to the accounting of energy supply / consumption by an enterprise for monetary settlement for it (accordingly, devices for commercial accounting are called commercial, or calculated). Technical, or control accounting is called accounting for the control of the process of supply / consumption of energy within the enterprise by its subdivisions and facilities (accordingly, technical accounting devices are used).

With the development of market relations, the restructuring of enterprises, the economic isolation of individual business units and the appearance of commercially independent but connected by a general scheme of power supply of production - subscribers, the functions of technical and accounting are combined within the same system. Accordingly, AMRMS of commercial and technical accounting can be implemented as separate systems or as a single system.

Two types of accounting, commercial and technical, have their own specifics. Commercial accounting is conservative, has a well-established scheme of energy supply, it is characterized by the presence of a small number of accounting points for which installation of devices of increased accuracy is required, and the means of accounting for the lower and middle level of AMR should be selected from the state register of measuring means. In addition,

commercial accounting systems are necessarily sealed, which limits the possibility of making any operational changes in them by the personnel of the enterprise.

Technical accounting, on the contrary, is dynamic and constantly evolving, reflecting the changing requirements of production; it is characterized by a large number of points of account with different tasks of monitoring energy resources, for which it is possible to install devices of lower accuracy for the purpose of saving money.

Technical control allows the use of devices that are not registered in the state register of measuring instruments, however, there may be problems with finding out the reasons for the unbalance of data on consumption of energy resources from commercial and technical accounting systems. The lack of sealing devices by the energy sales organization allows the service of the main power engineer of the enterprise to

promptly make changes in the scheme of technical control of energy resources, in the settings of primary measuring devices in accordance with the current changes in the scheme of power supply of the enterprise and the specificity of the solved production tasks. Taking into account this specificity of commercial and technical accounting, it is possible to optimize the cost of creating AMR and its operation. Energy accounting - a tool for energy saving. The constant rise in the cost of energy resources requires industrial enterprises to develop and implement a set of energy saving measures, including tight control over the supply / consumption of all types of energy resources, and limiting and reducing their share in the cost of production.

Modern ASCAE is a measuring tool that allows economically feasible development, implementation of a set of energy saving measures, timely correct it, ensuring dynamic optimization of energy costs in a

changing economic environment, thus, ASKUE is the basis of the system of energy saving of industrial enterprises. The first and most necessary step in this direction, which needs to be done today, is to introduce an automated accounting of energy resources that allows to take into account and control the parameters of all energy carriers throughout the entire structural hierarchy of the enterprise, with this control being brought to each workplace.

Due to this, production and non-production costs for energy resources will be minimized, it will allow solving disputable issues between the supplier and the consumer of energy resources not by strong-willed, directive measures, but objectively on the basis of objective automated accounting.

Glossary

- 1. Subscriber of power supply organization (Subscriber)** - The consumer of electric energy (heat), whose power installations are connected to the networks of the power supplying organization.
- 2. Emergency power system mode (Emergency reserve)** - The reserve of capacity necessary to perform an emergency reduction of generating capacity in the power system.
- 3. Emergency operation mode of the electric power plant (power station)** - The condition at which the power unit (power plant) is not able (not capable of) generating electrical energy with the capacity and (or) quality indicators established in the normative and technical documentation.
- 4. Emergency mode of the transformer** - Mode of operation in which the voltage or current of the winding or part of the winding is such that, for a sufficient duration, it threatens to damage or

destroy the transformer.

5. Emergency mode of electrical installation -

Operation of a faulty electrical installation, in which dangerous situations can occur that lead to electric trauma of people interacting with the electrical installation

6. Circuit breaker - Switch designed for automatic switching of an electrical circuit.

7. Autotransformer - A transformer, two or more windings of which are galvanically connected so that they share a common part.

8. Frequency Conversion Unit - An engine-generator, by means of which an alternating current of one frequency is converted into alternating current of another frequency.

9. Battery - A galvanic cell intended for multiple discharge due to the recovery of a capacitance by electric charge.

10. Accumulator battery - Electrically connected

batteries are equipped with leads and enclosed, as a rule, in one housing.

11.Active circuit - Electrical circuit containing sources of electrical energy.

12.Asynchronous operation of the power system (Asynchronous mode of the power system) - Transient regime, characterized by non-synchronous rotation of a part of power system generators.

13.Baseline power plant mode (Basic mode) - The operating mode of a power plant with a predetermined, practically constant power for a predetermined time interval.

14.Power system balance - The system of indicators characterizing the correspondence of the sum of the load values of the power system and the required reserve power to the available capacity of the power system.

15.Electricity balance of the power system - The

system of indicators that characterizes the correspondence of electricity consumption in the power system, its consumption for own needs and losses in electric networks to the amount of electricity production in the power system, taking into account power flows from other power systems.

16.Safety distance - The shortest distance between a person and the source of a hazardous and harmful production factor, in which a person is outside the danger zone.

17.Safety extra-low voltage - Voltage in the circuit electrically separated from the supply network by a safe isolation transformer not exceeding 50 V AC or $50\sqrt{2}$ V of pulsating direct current between the conductors or between any conductor and ground.

18.Safety of the production process - The property of the production process to meet the requirements of labor safety when carrying out it in conditions

established by regulatory and technical documentation.

19.Safe working conditions (Safety) - The condition of working conditions in which the impact on working dangerous and harmful production factors is excluded or the effect of harmful production factors does not exceed the maximum permissible values.

20.Safety isolating transformer - Separating transformer, designed to supply circuits with ultra-low safety voltage.

21.Reliability - The property of the object is to continuously maintain an operational state for some time or time.

22.Interlocking of an electrical product (device) - A part of an electrical product (device) designed to prevent or limit the performance of operations by parts of the product under certain conditions or positions of other parts of the product in order to

prevent the occurrence of unacceptable states in it or to exclude access to parts that are under voltage.

23.Varistor - Resistance, the value of which varies significantly depending on the applied voltage.

24.Input device - Lockable flap attached to the outer wall of the building and intended for the entry of external wiring or cable, their subsequent entry into the building and the transit exit leading to the next building.

25.Air Transformer - Dry leaky transformer, in which the main insulating and cooling medium is atmospheric air.

26.Recovery - The process of transferring an object into an operational state from an inoperative state.

Basic reference

1. Сапаев М.С., Алиев У.Е., Қодиров Ф.М. Алоқа қурилмаларининг электр таъминоти. Ўқув қўлланма: – Фан ва технология, Тошкент 2011, 248 бет.

2. Aloqa qurilmalarining elektr ta'minoti (o'quv qo'llanma). M.S. Sapayev, F.M. Qodirov, U.T. Aliyev. O'z.R.OO'MTV, – T.: “Iqtisod-moliya”, 2012 – 264 b.

3. Q.R. Allayev, I.H. Siddikov va bosh. Stantsiya va podstantsiyalarning elektr qismi. O'zR OO'MTV – T.: Cho'lpon nomidagi NMIU, 2016. 304 b.

Additional reference

1. Калугин Н.Г. Электропитание устройств и систем телекоммуникаций: учебник для студ. учреждений высш. проф. образования/. Н.Г.Калугин; под ред. Е.Е.Чаплыгина. - М.: Издательский центр «Академия», 2011. – 192 с. ISBN 978-5-7695-6857-2.

2. Гейтенко Е.Н. Источники вторичного электропитания. Схемотехника и расчет. Учебное пособие. – М.: Солон-пресс, 2008.-448 с.

3. Siddikov I.X. Aloqa qurilmalari qayta tiklanuvchi elektr ta'minoti manbalari fanidan uslubiy qo'llanma – Toshkent, TATU, 2016 – 92 b.

4. Majidov N.Sh. Noana'naviy va qayta tiklanuvchi energiya manbalari. O'zbekiston Respublikasi Oliy va O'rta maxsus ta'lim vazirligi tomonidan darslik sifatida tavsiya etilgan. T., 2014 – 177 b.

5. Телекоммуникация ускуналари электр таъминотига оид терминларнинг русча-ўзбекча изоҳли луғати./ М.Мухитдинов тахрири остида. Тошкент: Фан, 2009. -191 б.

6. Мурашко В.П., Системы кондиционирования воздуха. Теория и практика. Издательство: Евроклимат, -2017. -672 с. EAN-9785519501224.

