

51

511041

2-24 H.R. LATIPOV, R.R. ABZALIMOV,  
I.K. URAZBAYEVA

# OLIY MATEMATIKA

*O'zbekiston Respublikasi Oliy va o'rta maxsus ta'lim vazirligi  
texnik oliy o'quv yurtlarining talabalari uchun o'quv qo'llanma  
sifatida tavsiya etgan*

2033424

O'QUV ZALI

TATU KUTUBXONASI  
364330-SONLI

TOSHKENT - «ALOQACH» - 2005

H. R. Latipov, R. R. Abzalimov, I. K. Urazbayeva. Oliy matematika.  
T., «Aloqachi» nashriyoti, 2005, 180- bet.

**Taqrizchilar:** A.R.Beruniy nomidagi Toshkent Davlat Texnika universiteti «1-Oliy matematika» kafedrasida dotsenti **Sh.I.Tojiyev**, O'zbekiston Fanlar Akademiyasi matematika instituti katta ilmiy xodimi, fizika - matematika fanlari nomzodi **O. Sh. Sharipov**, Mirza Ulug'bek nomidagi O'zbekiston Milliy universitetining mexanika-matematika fakulteti dekani, dotsent **B. Shoimqulov**, Mirza Ulug'bek nomidagi O'zbekiston Milliy universitetining mexanika-matematika fakulteti «Ehtimollar nazariyasi va matematik statistika» kafedrasida dotsenti **A. Djamirzayev**, Mirza Ulug'bek nomidagi O'zbekiston Milliy universitetining «Matematik analiz» kafedrasida dotsenti **N. Sultonov**, Mirza Ulug'bek nomidagi O'zbekiston Milliy universitetining «Geometriya va matematika tarixi» kafedrasida mudiri, professor **A. Narmanov**, Mirza Ulug'bek nomidagi O'zbekiston Milliy universitetining «Geometriya va matematika tarixi» kafedrasining katta o'qituvchisi **F. Ibragimov**.

O'QUV ZALI

MUNDARIJA

So'z boshi ..... 4

I BOB. NAZARIY MA'LUMOTLAR

1-§. Chiziqli algebra va analitik geometriya.....6  
2-§. Matematik analizga kirish.....38  
3-§. Bir o'zgaruvchili funksiyaning integrali.....45  
4-§. Ko'p o'zgaruvchili funksiyalar.....49  
5-§. Oddiy differensial tenglamalar.....50  
6-§. Sonli va funksional qatorlar.....53  
7-§. Karrali, egri chiziqli integrallar.....54  
8-§. Kompleks o'zgaruvchili funksiyalar nazariyasi.....56  
9-§. Ehtimollar nazariyasi.....57  
10-§. Matematik statistika elementlari.....60

II BOB.

YOZMA ISH VARIANTLARINING  
NAMUNAVIY YECHIMLARI

1-§. Birinchi yozma ish.....63  
2-§. Ikkinchi yozma ish.....81  
3-§. Uchinchi yozma ish.....91  
4-§. To'rtinchi yozma ish.....102

III BOB. YOZMA ISH TOPSHIRIQLARI

1-§. Birinchi yozma ish topshiriqlari.....112  
2-§. Ikkinchi yozma ish topshiriqlari .....134  
3-§. Uchinchi yozma ish topshiriqlari.....149  
4-§. To'rtinchi yozma ish topshiriqlari.....163  
Adabiyotlar.....176  
Yozma ish variantlari.....177

## SO'Z BOSHI

Oliy texnika O'quv yurtlarida ta'lim olayotgan talabalarni keng miqyosda bilimli bakalavr mutaxassis qilib etishtirishning asosiy omillaridan biri oliy matematika fanini chuqur o'rganishdadir. Shuning bilan bir qatorda oliy texnika O'quv yurtlari uchun oliy matematika fani bo'yicha ajratilgan ma'ruza va amaliy darslar soati kam miqdorda bo'lganligi tufayli ularning chuqur bilim olishlari uchun mustaqil ish bajarish jarayonining ahamiyati juda xam kattadir. Oliy matematikadan o'zbek tilida oliy texnika O'quv yurtlari uchun talabalarning mustaqil ish bajarishlariga mo'ljallab yozilgan adabiyot va o'quv qo'llanmalar deyarli yo'q bo'lganligi uchun, talabalar oliy matematikadan mustaqil ish bajarish jarayonida katta qiyinchiliklarga duch kelishadi. Shu boisdan mazkur qo'llanma katta ahamiyat kasb etishi bilan bir qatorda, talabalar uchun oliy matematikani mustaqil yozma ish topshiriqlarini bajarib o'rganishda yaqindan yordam beradi.

Mazkur qo'llanma bakalavr muxandislar tayyorlash ta'lim va bilimlar sohasi yo'nalishi bo'yicha davlat standartiga mos kelishi bilan bir qatorda bu qo'llanma bakalavr mutaxassisligi bo'yicha «Oliy matematika» rejasida yozilgan. Bu o'quv qo'llanmada oliy texnika O'quv yurtlari talabalari uchun qisqacha nazariy ma'lumotlar va yozma ish topshiriqlari keltirilgan bo'lib, undan tashqari ko'rsatma sifatida har bir yozma ishdan bittadan variantning yechimi namunasi ko'rsatilgan.

Holisona taqriz va yo'l qo'yilgan kamchiliklarni ko'rsatganlari uchun Mirza Ulug'bek nomidagi O'zbekiston Milliy Universiteti, mexanika-matematika fakultetining «Ehtimollar nazariyasi va matematik statistika» kafedrasida dotsenti A. Djamirzaevga, «Matematik analiz» kafedrasida dotsentlari B. Shoimqulovga, N. Sultonovga, «Geometriya va matematika tarixi» kafedrasida mudiri prof. A. Narmanovga, katta o'qituvchi F. Ibragimovga, A.R.Beruniy nomidagi Toshkent

Davlat Texnika universiteti «Oliy matematika» kafedrası dotsenti Sh.I.Tojıeyvga, O'zbekiston Fanlar Akademiyasi matematika instituti katta ilmiy xodimi, fizika - matematika fanlari nomzodi O. Sh. Sharipovga mualliflar O'zlarining samimiy minnatdorchiliklarini bildiradilar.

Mazkur qo'llanma, albatta, kamchiliklardan xoli emas, shu sababdan mualliflar qo'llanmani yanada takomillashtirishga qaratilgan fikr-mulohazalarni minnatdorchilik bilan qabul qiladilar.

*Mualliflar*

# I BOB. NAZARIY MA'LUMOTLAR

## 1-§. CHIZIQLI ALGEBRA VA ANALITIK GEOMETRIYA

### Ikkinchi tartibli determinantlar va chiziqli tenglamalar sistemasini

$\begin{pmatrix} a_1 & b_1 \\ a_2 & b_2 \end{pmatrix}$  – jadvalga mos ikkinchi tartibli determinant

$$\begin{vmatrix} a_1 & b_1 \\ a_2 & b_2 \end{vmatrix} = a_1 b_2 - a_2 b_1$$

tenglik bilan aniqlanadi. Ikki noma'lumli ikkita chiziqli tenglamalar sistemasida

$$\begin{cases} a_1 x + b_1 y = c_1 \\ a_2 x + b_2 y = c_2 \end{cases}$$

uning asosiy determinanti  $D = \begin{vmatrix} a_1 & b_1 \\ a_2 & b_2 \end{vmatrix} \neq 0$  bo'lsa, u yagona

yechimga ega bo'lib, yechim Kramer formulalaridan topiladi:

$$x = \frac{D_x}{D} = \frac{\begin{vmatrix} c_1 & b_1 \\ c_2 & b_2 \end{vmatrix}}{\begin{vmatrix} a_1 & b_1 \\ a_2 & b_2 \end{vmatrix}}; \quad y = \frac{D_y}{D} = \frac{\begin{vmatrix} a_1 & c_1 \\ a_2 & c_2 \end{vmatrix}}{\begin{vmatrix} a_1 & b_1 \\ a_2 & b_2 \end{vmatrix}}$$

Agar  $D=0$  bo'lsa, sistema yoki birgalikda emas ( $D_x, D_y$  larning kamida bittasi noldan farqli), yoki cheksiz ko'p yechimga ega ( $D_x = D_y = 0$ ).

## Uchinchi tartibli determinant va chiziqli tenglamalar sistemasi

$$\begin{pmatrix} a_1 & b_1 & c_1 \\ a_2 & b_2 & c_2 \\ a_3 & b_3 & c_3 \end{pmatrix} \text{ elementlar jadvaliga mos uchinchi tartibli}$$

determinant

$$\begin{vmatrix} a_1 & b_1 & c_1 \\ a_2 & b_2 & c_2 \\ a_3 & b_3 & c_3 \end{vmatrix} = a_1 b_2 c_3 + a_2 b_3 c_1 + a_3 b_1 c_2 - a_3 b_2 c_1 - a_1 b_3 c_2 - a_2 b_1 c_3$$

tenglik bilan aniqlanadi.

Uchinchi tartibli determinantning berilgan elementini o'z ichiga olgan yo'l va ustunni o'chirishdan hosil bo'lgan ikkinchi tartibli determinantga uchinchi tartibli determinantning berilgan elementining minori deb ataladi. Minorning  $(-1)^k$  ga ko'paytmasi berilgan elementning algebraik to'ldiruvchisi deyiladi. ( $k$ - berilgan elementni o'z ichiga olgan yo'l va ustun nomerlari yig'indisi). Shunday qilib, determinantning

elementiga mos minor ishorasi quyidagi  $\begin{vmatrix} + & - & + \\ - & + & - \\ + & - & + \end{vmatrix}$  jadval

bilan aniqlanadi.

### 1-TEOREMA

**Uchinchi tartibli determinant ixtiyoriy yo'l (ustun) elementlarini o'z algebraik to'ldiruvchilariga ko'paytmalarining yig'indisiga teng**

Bu teorema determinantni ixtiyoriy yo'l elementlari bo'yicha yoyib, uning qiymatini hisoblashga yordam beradi.

Determinantning xossalari:

1. Agar determinantning yo'llarini ustunlari bilan yoki, ustunlarini yo'llari bilan almashtirsak, determinantning qiymati o'zgarmaydi.

2. Determinantning biror yo'lidagi yoki ustunidagi elementlari umumiy ko'paytuvchiga ega bo'lsa, uni determinantning tashqarisiga chiqarish mumkin.

3. Determinantning biror yo'l elementlari boshqa yo'l elementlariga teng bo'lsa, unday determinant nolga teng.

4. Agar determinantning ikkita yo'lining o'rnini almashirsak, uning ishorasi teskarisiga o'zgaradi.

5. Agar determinantning biror yo'l elementlariga boshqa yo'l elementlarini noldan farqli songa ko'paytirib qo'shsak, uning qiymati o'zgarmaydi.

Uch noma'lumli uchta chiziqli tenglamalar sistemasida

$$\begin{cases} a_1x + b_1y + c_1z = d_1 \\ a_2x + b_2y + c_2z = d_2 \\ a_3x + b_3y + c_3z = d_3 \end{cases}$$

uning asosiy determinanti

$$D = \begin{vmatrix} a_1 & b_1 & c_1 \\ a_2 & b_2 & c_2 \\ a_3 & b_3 & c_3 \end{vmatrix} \neq 0 \text{ bo'lsa, u yagona yechimga ega}$$

bo'lib, yechimni quyidagi Kramer formulalaridan foydalanib topiladi:

$$x = D_x/D, \quad y = D_y/D, \quad z = D_z/D,$$

Bu erda,

$$D_x = \begin{vmatrix} d_1 & b_1 & c_1 \\ d_2 & b_2 & c_2 \\ d_3 & b_3 & c_3 \end{vmatrix}, \quad D_y = \begin{vmatrix} a_1 & d_1 & c_1 \\ a_2 & d_2 & c_2 \\ a_3 & d_3 & c_3 \end{vmatrix}, \quad D_z = \begin{vmatrix} a_1 & b_1 & d_1 \\ a_2 & b_2 & d_2 \\ a_3 & b_3 & d_3 \end{vmatrix}$$

Agar  $D=0$  bo'lsa, sistema yoki birgalikda emas ( $D_x, D_y, D_z$  larning kamida bittasi noldan farqli), yoki cheksiz ko'p yechimga ega ( $D_x = D_y = D_z = 0$ ).

Agar bir jinsli sistema



$$\begin{cases} a_1x + b_1y + c_1z = 0 \\ a_2x + b_2y + c_2z = 0 \\ a_3x + b_3y + c_3z = 0 \end{cases}$$

ning determinanti noldan farqli bo'lsa, u yagona  $x=0, y=0, z=0$  yechimga ega bo'ladi. Agar bir jinsli sistemaning determinanti nolga teng bo'lsa, sistema ikkita tenglamaga yoki bitta tenglamaga keladi. Agar sistemaning minorlaridan kamida biri noldan farqli bo'lsa, birinchi xol, hamma minorlar nol bo'lsa, ikkinchi hol ro'y beradi. Bu ikki holda ham sistema cheksiz ko'p yechimlarga ega bo'ladi.

### n-nchi tartibli determinant

$$\begin{pmatrix} a_{11} & a_{12} & a_{13} & a_{14} \\ a_{21} & a_{22} & a_{23} & a_{24} \\ a_{31} & a_{32} & a_{33} & a_{34} \\ a_{41} & a_{42} & a_{43} & a_{44} \end{pmatrix}$$

elementlar jadvaliga mos keluvchi 4-tartibli determinant

$$\begin{vmatrix} a_{11} & a_{12} & a_{13} & a_{14} \\ a_{21} & a_{22} & a_{23} & a_{24} \\ a_{31} & a_{32} & a_{33} & a_{34} \\ a_{41} & a_{42} & a_{43} & a_{44} \end{vmatrix} = a_{11} \cdot \begin{vmatrix} a_{22} & a_{23} & a_{24} \\ a_{32} & a_{33} & a_{34} \\ a_{42} & a_{43} & a_{44} \end{vmatrix} - a_{12} \cdot \begin{vmatrix} a_{21} & a_{23} & a_{24} \\ a_{31} & a_{33} & a_{34} \\ a_{41} & a_{43} & a_{44} \end{vmatrix} + \\ + a_{13} \cdot \begin{vmatrix} a_{21} & a_{22} & a_{24} \\ a_{31} & a_{32} & a_{34} \\ a_{41} & a_{42} & a_{44} \end{vmatrix} - a_{14} \cdot \begin{vmatrix} a_{21} & a_{22} & a_{23} \\ a_{31} & a_{32} & a_{33} \\ a_{41} & a_{42} & a_{43} \end{vmatrix}$$

tenglik bilan aniqlanadi. Xuddi shuning kabi, 5-tartibli va hokazo tartibli determinant tushunchasini kiritish mumkin.

Ixtiyoriy tartibli determinantlar uchun, 3-tartibli determinantlarda kiritilgan algebraik to'ldiruvchilar haqidagi teorema va biror elementning minor hamda algebraik to'ldiruvchisi ta'rifi o'zgarasdan qoladi. Shunday qilib,  $a_{ik}$  elementning minorini  $M_{ik}$ , algebraik to'ldiruvchisini  $A_{ik}$  bilan belgilab,

$$A_{ik} = (-1)^{i+k} M_{ik}$$

ga ega bo'lamiz.

$D$  n-nchi tartibli determinant bo'lsin. Uni avval  $i$ -nchi yo'ning elementlari bo'yicha, so'ngra  $k$ -nchi ustunning elementlari bo'yicha yoyib, 1-teoreмага asosan,

$$D = a_{i1}A_{i1} + a_{i2}A_{i2} + \dots + a_{in}A_{in}$$

$$D = a_{1k}A_{1k} + a_{2k}A_{2k} + \dots + a_{nk}A_{nk}$$

ga ega bo'lamiz.

Ikkinchi va uchinchi tartibli determinantlarning xossalari ixtiyoriy tartibli determinantlar uchun o'rinlidir.

$$\begin{cases} a_{11}x_1 + a_{12}x_2 + \dots + a_{1n}x_n = b_1 \\ a_{21}x_1 + a_{22}x_2 + \dots + a_{2n}x_n = b_2 \\ \dots\dots\dots\dots\dots\dots\dots\dots\dots\dots \\ a_{n1}x_1 + a_{n2}x_2 + \dots + a_{nn}x_n = b_n \end{cases}$$

sistemaning determinanti

$$D = \begin{vmatrix} a_{11} & a_{12} & \dots & a_{1n} \\ a_{21} & a_{22} & \dots & a_{2n} \\ \dots & \dots & \dots & \dots \\ a_{n1} & a_{n2} & \dots & a_{nn} \end{vmatrix} \neq 0$$

bo'lsa, uning yechimlari  $x_1 = \frac{D_1}{D}$ ,  $x_2 = \frac{D_2}{D}$ , ...,  $x_n = \frac{D_n}{D}$

formulalardan topiladi. Bu formulalarda  $D$  - sistemaning determinanti,  $D_k$ , ( $k=1,2,\dots,n$ ) sistemaning determinantida  $k$ -nchi tartibli ustunni (aniqlanadigan noma'lumlar oldidagi

koeffitsientlar ustuni) ozod ustuni bilan almashtirishdan hosil bo'lgan:

$$D_k = \begin{vmatrix} a_{11} & a_{12} & \dots & a_{1,k-1} & b_1 & a_{1,k+1} & \dots & a_{1n} \\ a_{21} & a_{22} & \dots & a_{2,k-1} & b_2 & a_{2,k+1} & \dots & a_{2n} \\ \dots & \dots & \dots & \dots & \dots & \dots & \dots & \dots \\ a_{n1} & a_{n2} & \dots & a_{n,k-1} & b_n & a_{n,k+1} & \dots & a_{nn} \end{vmatrix}$$

determinant. Agar  $D = 0$  bo'lsa, sistema yoki birgalikda emas ( $D_1, D_2, \dots, D_n$  larning kamida bittasi noldan farqli), yoki cheksiz ko'p yechimga ega ( $D_1 = D_2 = \dots = D_n = 0$ ).

### To'g'ri chiziqdagi koordinatalar

$x$  absissaga ega bo'lgan  $OX$  koordina o'qining  $M$  nuqtasi  $M(x)$  bilan belgilanadi.  $M_1(x_1)$  va  $M_2(x_2)$  nuqtalar orasidagi masofa  $d = |x_2 - x_1|$  formula bilan aniqlanadi.

Ixtiyoriy to'g'ri chiziqda  $AB$  ( $A$ —kesmaning boshi,  $B$ —oxiri) kesma berilgan bo'lsin: u holda bu to'g'ri chiziqning ixtiyoriy  $C$  nuqtasi  $AB$  kesmani qandaydir  $\lambda$  nisbatda bo'ladi, bu erda  $\lambda = \pm |AC| : |CB|$ . Agar  $AC, CB$  kesmalar bir tomonga qarab yo'nalgan bo'lsa, "+" ishora, qarama-qarshi tomonga yo'nalgan bo'lsa "-" ishora olinadi. Boshqacha qilib aytganda, agar  $C$  nuqta  $A$  va  $B$  nuqtalar orasida yotsa,  $\lambda$  musbat, tashqarida yotsa, manfiy bo'ladi.

Agar  $A$  va  $B$  nuqtalar  $OX$  o'qida yotsa,  $A(x_1)$  va  $B(x_2)$  nuqtalarni  $\lambda$  nisbatda bo'luvchi  $C(\bar{x})$  nuqtaning koordinatalari

$$\bar{x} = \frac{x_1 + \lambda x_2}{1 + \lambda}$$

formula bilan aniqlanadi. Hususiy holda, agar  $\lambda=1$  bo'lsa, kesma o'rtasining koordinatalari uchun

$$\bar{x} = \frac{x_1 + x_2}{2}$$

formula kelib chiqadi.

## Tekislikdagi to'g'ri burchakli koordinatalar

Agar berilgan tekislikda XOY dekart koordinatalar sistemasi berilgan bo'lsa,  $x, y$  kordinataga ega bo'lgan  $M$  nuqtani  $M(x, y)$  bilan belgilaymiz.

$M_1(x_1, y_1), M_2(x_2, y_2)$  nuqtalar orasidagi masofa

$$d = \sqrt{(x_2 - x_1)^2 + (y_2 - y_1)^2}$$

formula bilan hisoblanadi. Xususiyl holda koordinata boshidan  $M(x, y)$  nuqttagacha bo'lgan masofa

$$d = \sqrt{x^2 + y^2}$$

formula bilan aniqlanadi.

$A(x_1, y_1), B(x_2, y_2)$  nuqtalar orasidagi kesmani berilgan  $\lambda$  nisbatda bo'luvchi  $C(\bar{x}, \bar{y})$  nuqtaning koordinatalari

$$\bar{x} = \frac{x_1 + \lambda x_2}{1 + \lambda}; \quad \bar{y} = \frac{y_1 + \lambda y_2}{1 + \lambda}$$

formulalar bilan aniqlanadi.

Xususiyl holda,  $\lambda=1$  bo'lganda, kesma o'rtasining koordinatalari:

$$\bar{x} = \frac{x_1 + x_2}{2}; \quad \bar{y} = \frac{y_1 + y_2}{2}$$

Uchlarining koordinatalari  $A(x_1, y_1), B(x_2, y_2), C(x_3, y_3)$  bo'lgan uchburchak yuzasi

$$C = \frac{1}{2} \cdot |x_1(y_2 - y_3) + x_2(y_3 - y_1) + x_3(y_1 - y_2)| =$$

$$\frac{1}{2} \cdot |(x_2 - x_1)(y_3 - y_1) + (x_3 - x_1)(y_2 - y_1)|$$

formula yordamida topiladi.

Uchburchak yuzasi  $C = \frac{1}{2} \Delta$

formula bilan hisoblanadi (bu erda,  $\Delta = \begin{vmatrix} 1 & 1 & 1 \\ x_1 & x_2 & x_3 \\ y_1 & y_2 & y_3 \end{vmatrix}$ ).

## Qutb koordinatalari

Qutb koordinatalarida  $M$  nuqtaning o'rnini uning  $O$  qutbdan masofasi  $|OM| = \rho$  ( $\rho$  - nuqtaning qutb radius - vektori) va  $OM$  kesmaning qutb o'qi  $OX$  bilan tashkil qilgan burchagi  $\theta$  ( $\theta$  - nuqtaning qutb burchagi) bilan aniqlanadi. Qutb o'qidan soat strelkasiga qarama - qarshi olingan  $\theta$  burchak musbat hisoblanadi. Agar  $M$  nuqta qutb koordinatalariga ega bo'lsa ( $\rho > 0$ ,  $0 \leq \theta < 2\pi$ ), unga cheksiz ko'p ( $\rho$ ,  $\theta + 2k\pi$ ), qutb koordinatlari jufti to'g'ri keladi,  $k \in Z$ .

Agar dekart koordinatalar sistemasining koordinata boshini qutbga qo'yib,  $OX$  o'qini qutb o'qi bo'yicha yo'naltirsak, u holda  $M$  nuqtaning to'g'ri burchakli  $(x, y)$  koordinatalari bilan  $(\rho, \theta)$  qutb koordinatalari o'rtasida bog'lanish quyidagi:

$$\begin{aligned}x &= \rho \cos \theta, & y &= \rho \sin \theta; \\ \rho &= \sqrt{x^2 + y^2}, & \operatorname{tg} \theta &= \frac{y}{x}\end{aligned}$$

formulalar bilan aniqlanadi.

## Fazodagi to'g'ri burchakli koordinatalar

Agar fazoda  $OXYZ$  to'g'ri burchakli dekart koordinatalar sistemasi berilgan bo'lsa, u holda koordinatalari  $x$  (absissa),  $y$  (ordinata) va  $z$  (aplikata) bo'lgan  $M$  nuqta  $M(x, y, z)$  bilan belgilanadi.  $A(x_1, y_1, z_1)$  va  $B(x_2, y_2, z_2)$  nuqtalar orasidagi masofa

$$d = \sqrt{(x_2 - x_1)^2 + (y_2 - y_1)^2 + (z_2 - z_1)^2}$$

formula bilan aniqlanadi.

$M(x; y; z)$  nuqtadan koordinata boshigacha bo'lgan masofa

$$d = \sqrt{x^2 + y^2 + z^2}$$

formula bilan topiladi.

Agar uchlari  $A(x_1, y_1, z_1)$  va  $B(x_2, y_2, z_2)$  bo'lgan kesma  $C(\bar{x}, \bar{y}, \bar{z})$  nuqta orqali  $\lambda$  nisbatda bo'lingan bo'lsa,  $C$  nuqtaning koordinatalari

$$\bar{x} = \frac{x_1 + \lambda x_2}{1 + \lambda}; \quad \bar{y} = \frac{y_1 + \lambda y_2}{1 + \lambda}; \quad \bar{z} = \frac{z_1 + \lambda z_2}{1 + \lambda}$$

tengliklardan topiladi.

Kesma o'rtasining koordinatalari

$$\bar{x} = \frac{x_1 + x_2}{2}; \quad \bar{y} = \frac{y_1 + y_2}{2}; \quad \bar{z} = \frac{z_1 + z_2}{2}$$

formulalar bilan topiladi.

## Vektorlar va ular ustida amallar

OXYZ koordinatalar sistemasida berilgan  $\bar{a}$  vektorni  $\bar{a} = a_x \cdot \bar{i} + a_y \cdot \bar{j} + a_z \cdot \bar{k}$  ko'rinishida tasvirlash mumkin.  $\bar{a}$  vektorni bunday tasvirlash uni koordinata o'qlari yoki ortlar bo'yicha yoyish deb ataladi. Bu erda  $a_x$ ,  $a_y$ ,  $a_z$  lar  $\bar{a}$  vektorning mos o'qlardagi proeksiyalari ( $\bar{a}$  vektorning koordinatalari) deyiladi,  $\bar{i}$ ,  $\bar{j}$ ,  $\bar{k}$  lar esa, o'qlarning ortlari (mos o'qlarning musbat yo'nalishi bilan ustma-ust tushgan birlik vektorlar).

$a_x \bar{i}$ ,  $a_y \bar{j}$ ,  $a_z \bar{k}$  lar  $\bar{a}$  vektorning koordinat o'qlari bo'yicha tashkil etuvchilari (komponentalari) deb ataladi.  $\bar{a}$  vektorning kattaligi  $|\bar{a}|$  bilan belgilanib,  $|\bar{a}| = \sqrt{a_x^2 + a_y^2 + a_z^2}$  formuladan topiladi.

$\bar{a}$  vektorning yo'nalishi uning koordinata o'qlari bilan tashkil qilgan  $\alpha$ ,  $\beta$ ,  $\gamma$  burchaklar orqali belgilanadi. Bu burchaklarning kosinuslari (vektorning yo'naltiruvchi kosinuslari)

$$\cos \alpha = \frac{a_x}{|\bar{a}|} = \frac{a_x}{\sqrt{a_x^2 + a_y^2 + a_z^2}}; \quad \cos \beta = \frac{a_y}{|\bar{a}|} = \frac{a_y}{\sqrt{a_x^2 + a_y^2 + a_z^2}};$$

$$\cos \gamma = \frac{a_z}{|\bar{a}|} = \frac{a_z}{\sqrt{a_x^2 + a_y^2 + a_z^2}}$$

formulalardan aniqlanadi.

Vektorning yo'naltiruvchi kosinuslari  $\cos^2 \alpha + \cos^2 \beta + \cos^2 \gamma = 1$  munosabat bilan bog'langan. Agar  $\vec{a}$  va  $\vec{b}$  vektorlar ortlar bo'yicha yoyilmasi bilan berilgan bo'lsa, ularning yig'indisi va ayirmasi

$$\vec{a} + \vec{b} = (a_x + b_x) \cdot \vec{i} + (a_y + b_y) \cdot \vec{j} + (a_z + b_z) \cdot \vec{k}$$

$$\vec{a} - \vec{b} = (a_x - b_x) \cdot \vec{i} + (a_y - b_y) \cdot \vec{j} + (a_z - b_z) \cdot \vec{k}$$

formulalardan aniqlanadi.

Boshlari ustma-ust tushadigan  $\vec{a}$  va  $\vec{b}$  vektorlar yig'indisi tomonlari  $\vec{a}$  va  $\vec{b}$  bo'lgan parallelogram diagonali bilan ustma-ust tushadigan vektor orqali tasvirlanadi.  $\vec{a} - \vec{b}$  ayirma shu parallelogramning ikkinchi diagonali bilan ustma-ust tushib, vektorning boshi  $\vec{b}$  ning oxirida, oxiri  $\vec{a}$  ning oxirida yotadi.

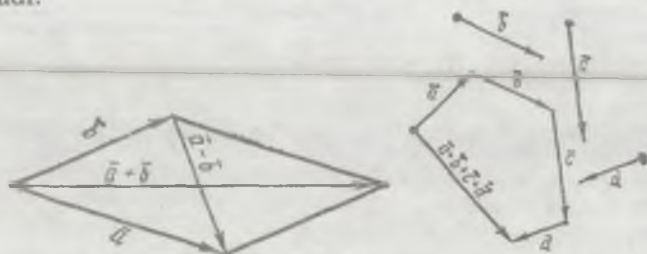

1-chizma

Ixtiyoriy sondagi vektorlar yig'indisi ko'pburchaklar qoidasi bo'yicha topiladi.  $\vec{a}$  vektorni  $m$  skalyarga ko'paytmasi  $m \cdot \vec{a} = m \cdot a_x \cdot \vec{i} + m \cdot a_y \cdot \vec{j} + m \cdot a_z \cdot \vec{k}$  formuladan topiladi. Agar  $m > 0$  bo'lsa,  $\vec{a}$  va  $m\vec{a}$  vektorlar parallel (kollineyar) va bir tomonga yo'nalgan,  $m < 0$  bo'lsa, qarama-qarshi tomonga yo'nalgan bo'ladi. Agar  $m = \frac{1}{|\vec{a}|}$  bo'lsa,  $\frac{\vec{a}}{|\vec{a}|}$

vektor uzunligi birga teng bo'lib, yo'nalishi  $\vec{a}$  ning yo'nalishi bilan ustma-ust tushadi. Bu vektor  $\vec{a}$  vektorning birlik vektori (ort) deyilib,  $\vec{a}_0$  bilan belgilanadi.  $\vec{a}$  vektor yo'nalishidagi birlik vektorni topish

$\vec{a}$  vektorni normallashtirish deyiladi. Shunday qilib,  $\vec{a}_0 = \frac{\vec{a}}{|\vec{a}|}$ ,

yoki  $\vec{a} = |\vec{a}| \cdot \vec{a}_0$ . Boshi  $A(x_1, y_1, z_1)$ , oxiri  $B(x_2, y_2, z_2)$  nuqtada

yotgan  $\overline{AB}$  vektor  $\overline{AB} = (x_2 - x_1)\vec{i} + (y_2 - y_1)\vec{j} + (z_2 - z_1)\vec{k}$  ko'rinishda bo'ladi. Uning uzunligi A va B nuqtalar orasidagi masofaga teng:

$$|\overline{AB}| = d = \sqrt{(x_2 - x_1)^2 + (y_2 - y_1)^2 + (z_2 - z_1)^2}$$

$\overline{AB}$  vektorning yo'nalishi quyidagi yo'naltiruvchi kosinuslar bilan aniqlanadi:

$$\cos \alpha = \frac{x_2 - x_1}{d}; \quad \cos \beta = \frac{y_2 - y_1}{d}; \quad \cos \gamma = \frac{z_2 - z_1}{d}$$

### Skalyar va vektor ko'paytma, aralash ko'paytma

$\vec{a}$  va  $\vec{b}$  vektorlarning skalyar ko'paytmasi deb  $\vec{a} \cdot \vec{b} = |\vec{a}| |\vec{b}| \cos \varphi$  skalyar kattalikka aytamiz.

*Skalyar ko'paytmaning xossalari:*

1.  $\vec{a} \cdot \vec{a} = |\vec{a}|^2$  yoki  $\vec{a}^2 = |\vec{a}|^2$ ;

2.  $\vec{a} \perp \vec{b}$  (noldan farqli vektorlar ortogonalligi) bo'lsa,  $\vec{a} \cdot \vec{b} = 0$  va aksincha;

3.  $\vec{a} \cdot \vec{b} = \vec{b} \cdot \vec{a}$  (o'rin almashtirish qonuni);

4.  $\vec{a}(\vec{b} + \vec{c}) = \vec{a}\vec{b} + \vec{a}\vec{c}$  (taqsimot qonuni);

5.  $(m\vec{a})\vec{b} = \vec{a}(m\vec{b}) = m(\vec{a}\vec{b})$  (skalyar ko'paytuvchiga nisbatan guruhlash qonuni).

$\vec{a} = a_x\vec{i} + a_y\vec{j} + a_z\vec{k}$ ,  $\vec{b} = b_x\vec{i} + b_y\vec{j} + b_z\vec{k}$  lar berilgan bo'lsa, ularning skalyar ko'paytmasi  $\vec{a}\vec{b} = a_x b_x + a_y b_y + a_z b_z$  formuladan topiladi.



$\vec{a}$  vektorning  $\vec{b}$  vektorga vektor ko'paytmasi deb shunday  $\vec{c}$  vektorga aytamizki, u quyidagi shartlarni qanoatlantirsin:

1.  $\vec{c}$  ning kattaligi  $\vec{a}$  va  $\vec{b}$  vektorlardan yasalgan parallelogramning yuziga teng ( $|\vec{c}| = |\vec{a}||\vec{b}|\sin\varphi$ ,  $\varphi = \vec{a} \wedge \vec{b}$ );
2.  $\vec{c}$  vektor  $\vec{a}$  va  $\vec{b}$  vektorlarga perpendikulyar;
3.  $\vec{a}, \vec{b}, \vec{c}$  vektorlar bitta nuqtaga keltirilgandan so'ng O'ng O'ng sistemani tashkil etsin. ( $\vec{a}, \vec{b}, \vec{c}$  vektorlar O'ng sistemani tashkil etadi deyiladi, agar  $\vec{a}$  dan  $\vec{b}$  ga va  $\vec{c}$  ga o'tish soat strelkasi harakatiga teskari yo'nalgan bo'lsa).

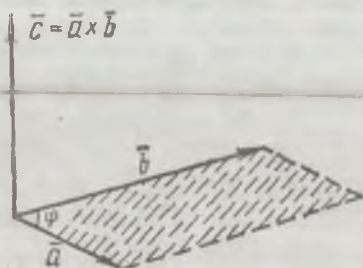

$\vec{a}$  vektorning  $\vec{b}$  vektorga vektor ko'paytmasi  $\vec{a} \times \vec{b}$  ko'rinishda yoziladi.

*Vektor ko'paytmaning xossalari:*

1.  $\vec{b} \times \vec{a} = -\vec{a} \times \vec{b}$ , O'rin almashtirish xossasiga ega emas;
  2. agar  $\vec{a} = 0$ , yoki  $\vec{b} = 0$ , yoki  $\vec{a} \parallel \vec{b}$  bo'lsa,  $\vec{a} \times \vec{b} = 0$  bo'ladi;
  3.  $(m\vec{a}) \times \vec{b} = \vec{a} \times (m\vec{b}) = m(\vec{a} \times \vec{b})$  (skalyar ko'paytuvchiga nisbatan guruhlash qonuni);
  4.  $\vec{a} \times (\vec{b} + \vec{c}) = \vec{a} \times \vec{b} + \vec{a} \times \vec{c}$  (taqsimot qonuni).
- $\vec{a} = x_1\vec{i} + y_1\vec{j} + z_1\vec{k}$ ,  $\vec{b} = x_2\vec{i} + y_2\vec{j} + z_2\vec{k}$  vektorlarning vektor ko'paytmasi

$$\overline{a \times b} = \begin{vmatrix} \bar{i} & \bar{j} & \bar{k} \\ x_1 & y_1 & z_1 \\ x_2 & y_2 & z_2 \end{vmatrix} \quad \text{formula yordamida topiladi.}$$

Uchta  $\overline{a}, \overline{b}, \overline{c}$  vektorning aralash ko'paytmasi  $\overline{a \times b}$  ni  $\overline{c}$  ga skalyar ko'paytmasiga teng, ya'ni  $(\overline{a \times b}) \cdot \overline{c}$ . Aralash ko'paytmaning moduli shu vektorlarga qurilgan parallelepipedning hajmiga teng. Aralash ko'paytmaning xossalari:

1. Agar:

- a) ko'paytiriluvchi vektorlardan biri nolga teng;
- b) ikkitasi kolleniar;
- v) uchta noldan farqli vektor bitta tekislikka parallel (komplanar) bo'lsa, aralash ko'paytma nolga teng.

2. Agar aralash ko'paytmada vektor ko'paytma va skalyar ko'paytmalarning o'rnini almashtirsak aralash ko'paytma o'zgarmaydi, ya'ni  $(\overline{a \times b}) \cdot \overline{c} = \overline{a} \cdot (\overline{b \times c})$ , shuni hisobga olib, aralash ko'paytma  $\overline{abc}$  kabi yoziladi.

3. Agar ko'paytiriladigan vektorlar o'rnini doiraviy shaklda almashtirsak, ko'paytma o'zgarmaydi:  $\overline{abc} = \overline{bca} = \overline{cab}$ .

4. Ixtiyoriy ikkita vektor o'rnini almashtirsak, aralash ko'paytmaning ishorasi o'zgaradi.

$$\overline{bac} = -\overline{abc}; \quad \overline{cba} = -\overline{abc}; \quad \overline{acb} = -\overline{abc}.$$

$\overline{a} = x_1 \bar{i} + y_1 \bar{j} + z_1 \bar{k}; \quad \overline{b} = x_2 \bar{i} + y_2 \bar{j} + z_2 \bar{k}; \quad \overline{c} = x_3 \bar{i} + y_3 \bar{j} + z_3 \bar{k}$   
vektorlarning aralash ko'paytmasi

$$\overline{abc} = \begin{vmatrix} x_1 & y_1 & z_1 \\ x_2 & y_2 & z_2 \\ x_3 & y_3 & z_3 \end{vmatrix} \quad \text{dan topiladi.}$$

Aralash ko'paytmaning xossalaridan quyidagilar kelib chiqadi: uch vektor komplanarligining zarur va yetarli sharti  $\overline{abc} = 0$  dir.  $\overline{a}, \overline{b}, \overline{c}$  lardan qurilgan parallelepiped najmi

$V_1 = |\overline{abc}|$ , uchburchakli piramidaning hajmi

$$V_2 = \frac{1}{6}V_1 = \frac{1}{6}|\overline{abc}| \text{ ga teng.}$$

### Matritsalar va ular ustida amallar

$$\begin{pmatrix} a_{11} & a_{12} \\ a_{21} & a_{22} \end{pmatrix} \cdot \begin{pmatrix} a_{11} & a_{12} & a_{13} \\ a_{21} & a_{22} & a_{23} \\ a_{31} & a_{32} & a_{33} \end{pmatrix}$$

lar mos ravishda 2 va 3- tartibli kvadrat matritsa deyiladi. Ko'p ta'riflarni umumlashtirish uchun ularni 3 tartibli matritsa uchun beriladi. Ularni 2- tartibli matritsa uchun qo'llash qiyinchilik tug'dirmaydi. Agar kvadrat matritsaning elementlari  $a_{mn} = a_{nm}$  shartni qanoatlantirsa, matritsa **simmetrik deyiladi**.

$$A = \begin{pmatrix} a_{11} & a_{12} & a_{13} \\ a_{21} & a_{22} & a_{23} \\ a_{31} & a_{32} & a_{33} \end{pmatrix}, \quad B = \begin{pmatrix} a_{11} & a_{12} & a_{13} \\ a_{21} & a_{22} & a_{23} \\ a_{31} & a_{32} & a_{33} \end{pmatrix}$$

matritsalar teng bo'lishi uchun ixtiyoriy  $m$  va  $n$  larda  $a_{mn} = b_{mn}$  shartning bajarilishi zarur va yetarlidir.

Har qanday  $A = \begin{pmatrix} a_{11} & a_{12} & a_{13} \\ a_{21} & a_{22} & a_{23} \\ a_{31} & a_{32} & a_{33} \end{pmatrix}$  matritsaga  $D_A = \begin{vmatrix} a_{11} & a_{12} & a_{13} \\ a_{21} & a_{22} & a_{23} \\ a_{31} & a_{32} & a_{33} \end{vmatrix}$

determinantni mos qo'yamiz. Agar  $D_A \neq 0$  bo'lsa, u holda,  $A$  matritsani xos emas matritsa deb ataymiz.

$A, B$  matritsalar yig'indisi quyidagicha aniqlanadi:

$$\begin{pmatrix} a_{11} & a_{12} & a_{13} \\ a_{21} & a_{22} & a_{23} \\ a_{31} & a_{32} & a_{33} \end{pmatrix} + \begin{pmatrix} b_{11} & b_{12} & b_{13} \\ b_{21} & b_{22} & b_{23} \\ b_{31} & b_{32} & b_{33} \end{pmatrix} = \begin{pmatrix} a_{11}+b_{11} & a_{12}+b_{12} & a_{13}+b_{13} \\ a_{21}+b_{21} & a_{22}+b_{22} & a_{23}+b_{23} \\ a_{31}+b_{31} & a_{32}+b_{32} & a_{33}+b_{33} \end{pmatrix}$$

$A$  matritsani  $m$  soniga ko'paytirish uchun uning har bir elementini  $m$  ga ko'paytiramiz:

$$m \cdot \begin{pmatrix} a_{11} & a_{12} & a_{13} \\ a_{21} & a_{22} & a_{23} \\ a_{31} & a_{32} & a_{33} \end{pmatrix} = \begin{pmatrix} ma_{11} & ma_{12} & ma_{13} \\ ma_{21} & ma_{22} & ma_{23} \\ ma_{31} & ma_{32} & ma_{33} \end{pmatrix}$$

A, B matritsalar ko'paytmasi quyidagicha aniqlanadi:

$$AB = \begin{pmatrix} a_{11} & a_{12} & a_{13} \\ a_{21} & a_{22} & a_{23} \\ a_{31} & a_{32} & a_{33} \end{pmatrix} * \begin{pmatrix} b_{11} & b_{12} & b_{13} \\ b_{21} & b_{22} & b_{23} \\ b_{31} & b_{32} & b_{33} \end{pmatrix} = \begin{pmatrix} \sum_{j=1}^3 a_{1j} b_{j1} & \sum_{j=1}^3 a_{1j} b_{j2} & \sum_{j=1}^3 a_{1j} b_{j3} \\ \sum_{j=1}^3 a_{2j} b_{j1} & \sum_{j=1}^3 a_{2j} b_{j2} & \sum_{j=1}^3 a_{2j} b_{j3} \\ \sum_{j=1}^3 a_{3j} b_{j1} & \sum_{j=1}^3 a_{3j} b_{j2} & \sum_{j=1}^3 a_{3j} b_{j3} \end{pmatrix}$$

Ko'paytma matritsaning i-nchi yo'l va k-nchi ustunda turuvchi elementi, A matritsa i-nchi yo'lidagi elementlarini B matritsa k-nchi ustunining mos elementlariga ko'paytmalari yig'indisiga teng.

Ikki matritsaning ko'paytmasi umuman o'rin almashtirish xossasiga bo'ysunmaydi. Ikki matritsa ko'paytmasining determinanti bu matritsalar determinantlari ko'paytmalariga teng. Hamma elementlari nollardan iborat bo'lgan matritsa nol matritsa deyiladi.

$$\begin{pmatrix} 0 & 0 & 0 \\ 0 & 0 & 0 \\ 0 & 0 & 0 \end{pmatrix} = 0$$

Bu matritsa uchun:  $A+0=A$ .

$$E = \begin{pmatrix} 1 & 0 & 0 \\ 0 & 1 & 0 \\ 0 & 0 & 1 \end{pmatrix} \text{ ni birlik matritsa deyiladi.}$$

Bu matritsani A ga chapdan va o'ngdan ko'paytmasi A ga teng:  $EA=AE=A$ . Agar  $AB=BA=E$  ga teng bo'lsa, B matritsa A-ga teskari matritsa deyiladi. A ga teskari matritsani  $A^{-1}$  bilan belgilanadi:  $B=A^{-1}$ . Har qanday xos emas matritsa teskari matritsaga ega. Teskari matritsa quyidagicha topiladi:

$$A^{-1} = \begin{pmatrix} \frac{A_{11}}{D_A} & \frac{A_{21}}{D_A} & \frac{A_{31}}{D_A} \\ \frac{A_{12}}{D_A} & \frac{A_{22}}{D_A} & \frac{A_{32}}{D_A} \\ \frac{A_{13}}{D_A} & \frac{A_{23}}{D_A} & \frac{A_{33}}{D_A} \end{pmatrix}$$

Bu erda  $A_{mn}$  - A matritsa determinantidagi  $a_{mn}$  elementning algebraik to'ldiruvchisidir, ya'ni  $A_{mn}$  - A matritsa determinantidagi  $m$  - nchi yo'l va  $n$ -nchi ustunini o'chirishdan hosil bo'lgan ikkinchi tartibli determinant (minor) bilan  $(-1)^{m+n}$  ifoda ko'paytmasidir.

$$X = \begin{pmatrix} x_1 \\ x_2 \\ x_3 \end{pmatrix} - \text{ni ustun matritsa deyiladi.}$$

AX ko'paytma quyidagicha aniqlanadi:

$$AX = \begin{pmatrix} a_{11} & a_{12} & a_{13} \\ a_{21} & a_{22} & a_{23} \\ a_{31} & a_{32} & a_{33} \end{pmatrix} \begin{pmatrix} x_1 \\ x_2 \\ x_3 \end{pmatrix} = \begin{pmatrix} a_{11}x_1 + a_{12}x_2 + a_{13}x_3 \\ a_{21}x_1 + a_{22}x_2 + a_{23}x_3 \\ a_{31}x_1 + a_{32}x_2 + a_{33}x_3 \end{pmatrix}$$

$$\begin{cases} a_{11}x_1 + a_{12}x_2 + a_{13}x_3 = b_1 \\ a_{21}x_1 + a_{22}x_2 + a_{23}x_3 = b_2 \\ a_{31}x_1 + a_{32}x_2 + a_{33}x_3 = b_3 \end{cases}$$

sistemani  $AX=B$  ko'rinishda yozish mumkin, bu erda,

$$A = \begin{pmatrix} a_{11} & a_{12} & a_{13} \\ a_{21} & a_{22} & a_{23} \\ a_{31} & a_{32} & a_{33} \end{pmatrix}, \quad X = \begin{pmatrix} x_1 \\ x_2 \\ x_3 \end{pmatrix}, \quad B = \begin{pmatrix} b_1 \\ b_2 \\ b_3 \end{pmatrix}$$

Bu sistemaning yechimi  $X = A^{-1} \cdot B$  ( $D_A \neq 0$ ) bo'ladi.

$$\begin{pmatrix} a_{11} & a_{12} & a_{13} \\ a_{21} & a_{22} & a_{23} \\ a_{31} & a_{32} & a_{33} \end{pmatrix} \text{ matritsaning xarakteristik tenglamasi}$$

$$\begin{vmatrix} a_{11} - \lambda & a_{12} & a_{13} \\ a_{21} & a_{22} - \lambda & a_{23} \\ a_{31} & a_{32} & a_{33} - \lambda \end{vmatrix} = 0.$$

Bu tenglamaning ildizlari  $\lambda_1, \lambda_2, \lambda_3$  lar matritsaning xos sonlari deyiladi. Bu xos sonlarga mos keluvchi xos vektorlarning koordinatalari quyidagi:

$$\begin{cases} (a_{11} - \lambda)\zeta_1 + a_{12}\zeta_2 + a_{13}\zeta_3 = 0 \\ a_{21}\zeta_1 + (a_{22} - \lambda)\zeta_2 + a_{23}\zeta_3 = 0 \\ a_{31}\zeta_1 + a_{32}\zeta_2 + (a_{33} - \lambda)\zeta_3 = 0 \end{cases}$$

tenglamalar sistemasi yechimlaridan iborat bo'ladi.

### Matritsaning rangi. Ekvivalent matritsalar

To'g'ri burchakli matritsa berilgan bo'lsin.

$$A = \begin{pmatrix} a_{11} & a_{12} \dots & a_{1n} \\ a_{21} & a_{22} \dots & a_{2n} \\ a_{m1} & a_{m2} \dots & a_{mn} \end{pmatrix}$$

Bu matritsadan ixtiyoriy  $k$ -ta yo'l,  $k$ -ta ustun ajratamiz ( $k \leq m, k \leq n$ ).  $A$  matritsaning ajratilgan yo'l va ustunlarining kesishgan joyida turgan elementlaridan tuzilgan  $k$ -nchi tartibli determinant  $A$  matritsaning  $k$ -nchi tartibli minori deyiladi.  $A$  matritsa  $C_m^k \cdot C_n^k$  ta  $k$ -nchi tartibli minorlarga ega.  $A$  matritsaning noldan farqli hamma minorlarini qaraymiz.  $A$  matritsaning rangi deb uning noldan farqli minorlarining eng yuqori tartibiga aytamiz. Agar matritsaning hamma elementlari nollardan iborat bo'lsa, uning rangi nolga teng. Tartibi matritsaning rangiga teng bo'lgan noldan farqli har qanday minor matritsaning bazis minori deyiladi. Matritsaning rangini  $r(A)$  bilan belgilaymiz. Agar  $r(A) = r(B)$  ga teng bo'lsa,  $A$  va  $B$  lar ekvivalent matritsalar deyiladi va  $A \sim B$  kabi yoziladi. Elementar almashtirishlardan matritsaning rangi o'zgarmaydi.

Elementar almashtirishlarga quyidagilar kiradi:

1. Matritsaning yo'llarini ustunlar bilan almashtirish.
2. Matritsaning yo'llarini o'zaro almashtirish.
3. Hamma elementlari nollardan iborat yo'llarni o'chirish.
4. Birorta yo'lini noldan farqli songa ko'paytirish.
5. Biror yo'l elementlariga boshqa yo'lning mos elementlarini qo'shish.

### Chiziqli almashtirish

$$x = a_{11}x' + a_{12}y'$$

$$y = a_{21}x' + a_{22}y'$$

tenglik orqali  $x$ ,  $y$  o'zgaruvchilarni  $x'$ ,  $y'$  orqali ifodalash mumkin. Bu tenglikni  $x'$ ,  $y'$  o'zgaruvchilarni chiziqli almashtirish deyiladi.

$$A = \begin{pmatrix} a_{11} & a_{12} \\ a_{21} & a_{22} \end{pmatrix}$$

jadval qaralayotgan chiziqli almashtirish matritsasi deyiladi.

$$D_A = \begin{vmatrix} a_{11} & a_{12} \\ a_{21} & a_{22} \end{vmatrix}$$

chiziqli almashtirishlarning determinanti deyiladi. Bundan so'ng  $D_A \neq 0$  deb qaraladi.

Chiziqli almashtirishni uch o'zgaruvchili deb qarash mumkin:

$$x = a_{11}x' + a_{12}y' + a_{13}z'$$

$$y = a_{21}x' + a_{22}y' + a_{23}z'$$

$$z = a_{31}x' + a_{32}y' + a_{33}z'$$

bu erda,

$$A = \begin{pmatrix} a_{11} & a_{12} & a_{13} \\ a_{21} & a_{22} & a_{23} \\ a_{31} & a_{32} & a_{33} \end{pmatrix}, \quad D_A = \begin{vmatrix} a_{11} & a_{12} & a_{13} \\ a_{21} & a_{22} & a_{23} \\ a_{31} & a_{32} & a_{33} \end{vmatrix}$$

lar bu chiziqli almashtirishning mos ravishda matritsa  $A$  ning determinanti deyiladi.

## Gauss usuli bilan chiziqli tenglamalar sistemasini echish

Chiziqli algebraik tenglamalarni determinant yordamida echish ikki va uch noma'lumli tenglamalar sistemasini uchun qulay. Tenglamalar soni sistemada ko'p bo'lganda Gauss usuli qulay. Bu usulni 4 noma'lumli 4 ta tenglamalar sistemasida tahlil qilamiz:

$$\begin{cases} a_{11}x + a_{12}y + a_{13}z + a_{14}u = a_{15} & (a) \\ a_{21}x + a_{22}y + a_{23}z + a_{24}u = a_{25} & (b) \\ a_{31}x + a_{32}y + a_{33}z + a_{34}u = a_{35} & (c) \\ a_{41}x + a_{42}y + a_{43}z + a_{44}u = a_{45} & (d) \end{cases}$$

$a_{11} \neq 0$  deb faraz qilamiz, (agar  $a_{11} = 0$  bo'lsa, tenglamalarning o'rnini almashtiramiz).

1-qadam. (a) tenglamani  $a_{11}$  ga bo'lib, hosil bo'lgan tenglamani  $a_{21}$  ga ko'paytirib (b) dan ayiramiz, so'ngra  $a_{31}$  ga ko'paytirib (c) dan ayiramiz,  $a_{41}$  ga ko'paytirib (d) dan ayiramiz. Birinchi qadamdan so'ng quyidagi sistemaga kelamiz:

$$\begin{cases} x + b_{12}y + b_{13}z + b_{14}u = b_{15} & (e) \\ b_{22}y + b_{23}z + b_{24}u = b_{25} & (f) \\ b_{32}y + b_{33}z + b_{34}u = b_{35} & (g) \\ b_{42}y + b_{43}z + b_{44}u = b_{45} & (h) \end{cases}$$

$b_{ij}$  ni  $a_{ij}$  lardan quyidagi formulalar bo'yicha topiladi:

$$b_{1j} = \frac{a_{1j}}{a_{11}} \quad (j = 2, 3, 4, 5)$$

$$b_{ij} = a_{ij} - a_{i1} \cdot b_{1j} \quad (i=2, 3, 4; j=2, 3, 4, 5).$$



2- qadam. (a), (b), (c), (d) tenglamalarda nima qilgan bo'lsak, (f), (g), (h) larda ham shularni qaytaramiz va hokazo. Natijada berilgan tenglama quyidagi ko'rinishga keladi:

$$\begin{cases} x + b_{12}y + b_{13}z + b_{14}u = b_{15} \\ y + c_{23}z + c_{24}u = c_{25} \\ z + d_{34}u = d_{35} \\ u = e_{45} \end{cases}$$

Hosil bo'lgan sistemadan barcha noma'lumlar ketma-ket topiladi.

### Chiziq tenglamasi

XOY tekisligida biror chiziqni nuqtalar to'plami deb qarasaq, unga bu chiziqda yotgan ixtiyoriy  $M(x, y)$  nuqta koordinatalarini bog'lovchi tenglama to'g'ri keladi. Bunday tenglama berilgan chiziqning tenglamasi deb ataladi. Agar berilgan chiziqning tenglamasiga bu chiziqda yotgan ixtiyoriy nuqtaning koordinatalarini qo'ysak, uni ayniyatga aylantiradi. Chiziqdan tashqaridagi nuqtaning koordinatalari bu chiziq tenglamasini qanoatlantirmaydi.

### Chiziqning parametrik tenglamasi

Ba'zida nuqtalar to'plamining tenglamasini tuzishda  $x, y$  koordinatalarni qandaydir yordamchi parametr  $t$  orqali ifodalash qulay keladi (uni parametr deb ataladi), ya'ni  $x = \varphi(t), y = \psi(t)$  tenglamalar sistemasi qaraladi. Izlangan chiziqni bunday tasvirlash parametrik ko'rinish deyilib, tenglamalar sistemasi berilgan chiziqning parametrik tenglamalari deyiladi. Tenglamalar sistemasidan parametr  $t$  ni yuqotib,  $x, y$  ni bog'lovchi, ya'ni oddiy  $f(x, y) = 0$  ko'rinishdagi tenglamaga keltiriladi.

## To'g'ri chiziqning umumiy tenglamasi

$x$ ,  $y$  larga nisbatan har qanday birinchi darajali tenglama, ya'ni

$$Ax+By+C=0$$

$A$ ,  $B$ ,  $C$  – lar o'zgarimas koeffitsientlar) tenglama tekislikda qandaydir to'g'ri chiziqni aniqlaydi va tekislikdagi har qanday to'g'ri chiziqning tenglamasini 1-darajali  $Ax+By+C=0$  tenglama ko'rinishida yozish mumkin. Bu tenglama to'g'ri chiziqning umumiy tenglamasi deb ataladi.

Xususiy hollar:

1.  $C=0$ ;  $A \neq 0$ ;  $B \neq 0$ .  $Ax+By=0$  tenglama bilan aniqlanadigan to'g'ri chiziq koordinatalar boshidan o'tadi.

2.  $A=0$ ;  $B \neq 0$ ;  $C \neq 0$ .  $By+C=0$  tenglama bilan aniqlanadigan ( $y=-C/B$ ) to'g'ri chiziq  $OX$  o'qiga parallel.

3.  $B=0$ ;  $A \neq 0$ ;  $C \neq 0$ .  $Ax+C=0$  tenglama bilan aniqlanadigan ( $x=-C/A$ ) to'g'ri chiziq  $OY$  o'qiga parallel.

4.  $B=C=0$ ;  $A \neq 0$ ;  $Ax=0$  yoki  $x=0$  tenglama bilan aniqlanadigan to'g'ri chiziq  $OY$  o'qi bilan ustma-ust tushadi.

5.  $A=C=0$ ;  $B \neq 0$ ,  $By=0$  yoki  $y=0$  tenglama bilan aniqlanadigan to'g'ri chiziq  $OX$  o'qi bilan ustma-ust tushadi.

## To'g'ri chiziqning burchak koeffitsientli tenglamasi

Agar umumiy tenglamada  $B \neq 0$  bo'lsa, uni  $y$ -ka nisbatan echib  $y=kx+b$  tenglamani hosil qilamiz (bu erda  $k=-A/B$ ,  $b=-C/B$ ). Uni to'g'ri chiziqning burchak koeffitsientli tenglamasi deb atashadi, bu erda,  $k = \operatorname{tg} \alpha$ ,  $\alpha$  – to'g'ri chiziq bilan  $OX$  o'qining musbat yo'nalishi orasidagi burchak. Tenglamaning ozod hadi  $b$  to'g'ri chiziqning  $OY$  o'qi bilan kesishgan nuqtasi.

## To'g'ri chiziqning kesmalarga nisbatan tenglamasi

Agar to'g'ri chiziqning umumiy tenglamasida  $C \neq 0$  bo'lsa, tenglamani  $-C$  ga bo'lib,

$$\frac{x}{a} + \frac{y}{b} = 1$$

tenglikka ega bo'lamiz (bu erda,  $a=-C/A$ ,  $b=-C/B$ ). Uni to'g'ri chiziqning kesmalarga nisbatan tenglamasi deb atashadi; bunda,  $a$  – to'g'ri chiziqning OX o'qi,  $b$  – esa OY o'qi bilan kesishish nuqtasi. Shuning uchun,  $a$ ,  $b$  larga to'g'ri chiziqning o'qlardagi kesmalari deyiladi.

### To'g'ri chiziqning normal tenglamasi

Agar to'g'ri chiziqning umumiy tenglamasining ikki tomonini  $\mu = 1/\pm\sqrt{A^2+B^2}$  ga ko'paytirsak ( $\mu$ -normallashtiruvchi ko'paytuvchi, ildiz oldidagi ishorani shunday tanlaymizki,  $\mu C < 0$  bo'lsin)

$$x \cos \varphi + y \sin \varphi - P = 0$$

ga ega bo'lamiz. Bu tenglikka to'g'ri chiziqning normal tenglamasi deyiladi. Bu erda  $P$  koordinatalar boshidan to'g'ri chiziqqa tushirilgan perpendikulyarning uzunligi,  $\varphi$ -perpendikulyar bilan OX o'qining musbat yunalishi orasidagi burchak.

### To'g'ri chiziqlar orasidagi burchak. Ikki nuqtadan o'tuvchi to'g'ri chiziq tenglamasi

$y=k_1x+b_1$ ,  $y=k_2x+b_2$  to'g'ri chiziqlar orasidagi burchak

$$\operatorname{tg} \alpha = \left| \frac{k_2 - k_1}{1 + k_1 k_2} \right|$$

formula bilan aniqlanadi.  $k_1 = k_2$  ikki chiziqning paralellik sharti.  $k_1 = -1/k_2$  ikki to'g'ri chiziqning perpendikulyarlik sharti.  $k$  burchak koeffitsientli va  $M(x_1, y_1)$  nuqtadan o'tuvchi to'g'ri chiziq tenglamasi quyidagi:

$$y - y_1 = k(x - x_1)$$

ko'rinishda yoziladi.  $M_1(x_1, y_1)$  va  $M_2(x_2, y_2)$  nuqtalardan o'tuvchi to'g'ri chiziq tenglamasi

$$\frac{y - y_1}{y_2 - y_1} = \frac{x - x_1}{x_2 - x_1}$$

bo'lib, bu to'g'ri chiziqning burchak koeffitsienti

$$k = \frac{y_2 - y_1}{x_2 - x_1}$$

formuladan topiladi. Agar  $x_1 = x_2$  bo'lsa,  $M_1, M_2$  nuqtalardan o'tuvchi to'g'ri chiziq tenglamasi  $x = x_1$ ,  $y_1 = y_2$  bo'lsa  $y = y_1$  bo'ladi.

### To'g'ri chiziqlarning kesishuvi. Nuqtadan to'g'ri chiziqqacha masofa

Agar  $A_1/A_2 \neq B_1/B_2$  bo'lsa,  $A_1x + B_1y + C_1 = 0$  va  $A_2x + B_2y + C_2 = 0$  to'g'ri chiziqlarning kesishgan nuqtasini ularning tenglamalari birga echib topiladi.

$M(x_0, y_0)$  nuqtadan  $Ax + Bx + C = 0$  to'g'ri chiziqqacha masofa

$$d = \frac{|Ax_0 + By_0 + C|}{\sqrt{A^2 + B^2}}$$

formuladan topiladi.

$A_1x + B_1y + C_1 = 0$  va  $A_2x + B_2y + C_2 = 0$  to'g'ri chiziqlar orasidagi burchak bissektrisasining tenglamasi

$$\frac{A_1x + B_1y + C_1}{\sqrt{A_1^2 + B_1^2}} + \frac{A_2x + B_2y + C_2}{\sqrt{A_2^2 + B_2^2}} = 0$$

bo'ladi.

### Ikkinchi tartibli egri chiziqlar. Aylana

Aylana deb, tekislikdagi shunday nuqtalarning to'plamiga aytiladiki, bu nuqtalarning har biridan shu tekislikdagi markaz deb ataluvchi nuqtagacha bo'lgan masofa o'zgarmas miqdordir.

Bu o'zgarmas miqdor  $r$ -ni aylananing radiusi,  $C(a; b)$ -nuqtani uning markazi desak, aylananing tenglamasi

$$(x-a)^2 + (y-b)^2 = r^2$$

ko'rinishda bo'ladi. Aylana markazi koordinata boshi bilan ustma-ust tushsa, aylana tenglamasi  $x^2+y^2=r^2$  bo'ladi. Agar  $x_1^2 + y_1^2 = r^2$  bo'lsa,  $M(x_1; y_1)$  nuqta aylanada yotadi,  $x_1^2 + y_1^2 > r^2$  bo'lsa,  $M$  nuqta aylanadan tashqarida  $x_1^2 + y_1^2 < r^2$  bo'lsa, nuqta aylana ichida yotadi.

## Ellips

Ellips deb, tekislikdagi shunday nuqtalarning to'plamiga aytiladiki, bu nuqtalarning har biridan fokuslar deb ataluvchi ikki nuqttagacha bo'lgan masofalar yig'indisi o'zgarmas miqdordir, u  $2a$  bilan belgilanadi, bu o'zgarmas miqdor fokuslar orasidagi masofadan katta bo'ladi.

Agar koordinata o'qlari ellipsga nisbatan simmetrik joylashib, ellipsning fokuslari esa  $Ox$  o'qida koordinata boshidan bir xil masofada ( $F_1(s,0)$ ,  $F_2(-s,0)$ ) yotsa, ellipsning

oddiy (kanonik) tenglamasi  $\frac{x^2}{a^2} + \frac{y^2}{b^2} = 1$  ko'rinishda bo'ladi.

$a$  - ellipsning katta,  $b$  - kichik yarim o'qi,  $a$ ,  $b$ ,  $c$  ( $c$  - fokuslar orasidagi masofaning yarmi) lar orasida  $a^2 = b^2 + c^2$  munosabat bor. Ellipsning shakli (siqilish o'lchovi) uning eksentrisiteti  $e = c/a$  ( $c < a$  bo'lgani uchun  $e < 1$ ) bilan xarakterlanadi.

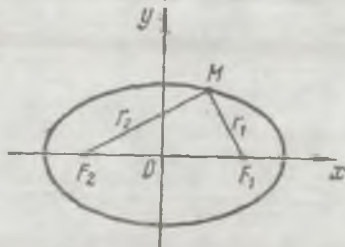

Ellipsning biror  $M$  nuqtasidan fokuslargacha bo'lgan masofalarni nuqtaning fokal radius-vektorlari deb ataladi. Ular  $r_1$ ,  $r_2$  bilan belgilanadi (ellipsning ta'rifiga ko'ra uning ixtiyoriy nuqtasi uchun  $r_1 + r_2 = 2a$  bo'ladi). Xususiyl holda,  $a = b$  ( $c = 0$ ,  $e = 0$ ) fokuslar markaz bilan ustma-ust tushsa) bo'lsa, ellips aylanaga aylanib qoladi:  $x^2 + y^2 = a^2$ .  $M(x_1; y_1)$  nuqta va  $x^2/a^2 + y^2/b^2 = 1$  ellipsning o'zaro joylanishi quyidagi shartlar bilan aniqlanadi:

agar  $x_1^2/a^2 + y_1^2/b^2 = 1$  bo'lsa, M nuqta ellipsda yotadi; agar  $x_1^2/a^2 + y_1^2/b^2 < 1$  bo'lsa, M nuqta ellipsdan tashqarida; agar  $x_1^2/a^2 + y_1^2/b^2 > 1$  bo'lsa, M nuqta ellips ichida yotadi. Fokal radius-vektorlar ellips nuqtalarining absissasi orqali  $r_1 = a - ex$  (o'ng fokal radius-vektor),  $r_2 = a + ex$  (chap fokal radius-vektor) bilan ifodalanadi.

## Giperbola

Giperbola deb, tekislikdagi shunday nuqtalarning to'plamiga aytiladiki, bu nuqtalarning har biridan fokuslar deb ataluvchi ikki nuqtasigacha bo'lgan masofalar ayirmalarining absolyut qiymatlari o'zgarmas miqdordir. Bu o'zgarmas miqdor  $2a$  bilan belgilanadi, u fokuslar orasidagi masofadan kichik. Agar giperbolaning fokuslarini  $F_1(s,0)$ ,  $F_2(-s,0)$  nuqtalarga joylashtirsak, u holda giperbolaning

$$x^2/a^2 - y^2/b^2 = 1$$

kanonik tenglamasiga ega bo'lamiz, bu erda,  $b^2 = c^2 - a^2$ . Giperbola ikki tarmoqdan iborat va koordinata o'qlariga nisbatan simmetrik joylashgan.  $A_1(a, 0)$ ,  $A_2(-a, 0)$  lar giperbolaning uchlari deb ataladi.  $|A_1A_2| = a$  giperbolaning haqiqiy,  $|B_1B_2| = b$  mavhum o'qi deyiladi.

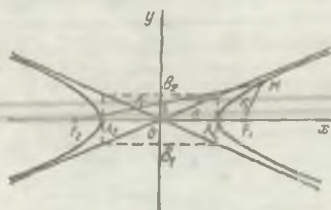

Agar giperbolaning  $M(x, y)$  nuqtasidan biror to'g'ri chiziqqacha bo'lgan masofasi nolga intilsa ( $x \rightarrow +\infty$  yoki  $x \rightarrow -\infty$  da), u to'g'ri chiziq giperbolaning asimptotasi deyiladi. Giperbola ikkita asimptotaga ega, ular  $y = \pm(b/a)x$ . Giperbolaning asimptotalarini yasash uchun tomonlari  $x=a$ ,  $x=-a$ ,  $y=b$ ,  $y=-b$  bo'lgan to'g'ri to'rtburchak chizamiz. Bu to'g'ri to'rtburchakning qarama-qarshi uchlaridan o'tkazilgan to'g'ri chiziq giperbolaning asimptotalari bo'ladi.

$e=c/a>1$  nisbat giperbolaning eksstentrisiteti deyiladi.  $r_1=ex-a$  (o'ng fokal radius-vektor)  $r_1=ex+a$  (chap fokal radius-vektori) giperbola o'ng tarmog'ining fokal radius-vektorlari deyiladi. Xuddi shunday chap tarmog'ining fokal radius-vektorlari  $r_1=-ex+a$ ,  $r_1(-ex-a)$  bo'ladi. Agar  $a=b$  bo'lsa, giperbolaning tenglamasi  $x^2-y^2=a^2$  bo'ladi. Bunday giperbola teng tomonli deb ataladi. Uning asimptotalari to'g'ri burchak hosil qiladi. Agar koordinata o'qlarini asimptotalar deb qarasaq (teng tomonli giperbolada), uning tenglamasi  $xy=m$  ( $m=\pm a^2/2$ ;  $m>0$  bo'lsa, giperbola I va III chorakda,  $m<0$  bo'lsa, II va IV chorakda yotadi.  $xy=m$  tenglamani  $y=m/x$  ko'rinishda yozish mumkin bo'lgani uchun, teng tomonli giperbola  $x,y$  miqdorlar orasidagi teskari proporsional bog'lanishni ifodalaydi.

$x^2/a^2 - y^2/b^2 = 1$  va  $x^2/a^2 - y^2/b^2 = -1$  giperbolalar bir xil yarim o'qqa va bir xil asimptotaga ega, lekin haqiqiy va mavhum o'qlari almashinib keladi. Bunday giperbolalar qo'shma deb ataladi.

## Parabola

Berilgan nuqta va berilgan to'g'ri chiziqdan barobar uzoqlikda turgan nuqtalarning to'plami parabola deb ataladi. Nuqta fokus, to'g'ri chiziq direktrisa deb ataladi. Agar parabolaning direktrisasi  $x=-r/2$ , fokusi  $F(r/2;0)$  nuqta bo'lsa, uning tenglamasi  $y^2=2px$  bo'ladi.

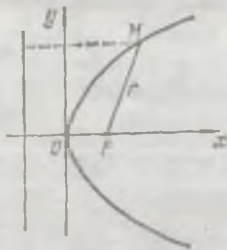

Bu parabola absissa o'qiga nisbatan simmetrik joylashgan ( $p>0$ ).  $x^2=2py$  tenglama ordinata o'qiga nisbatan simmetrik bo'lgan parabola bo'ladi.  $p>0$  da parabola mos o'qlarining musbat tomoniga,  $p<0$  bo'lsa, manfiy tomoniga qaragan

bo'ladi.  $y^2=2px$  parabolaning fokal radius - vektorining uzunligi  $r=x+p/2$  ( $p>0$ ) formula bilan aniqlanadi.

### Fazodagi analitik geometriya. Tekislik va to'g'ri chiziq. Tekislik

Agar  $A^2 + B^2 + C^2 \neq 0$  bo'lsa, har qanday 1-darajali  $Ax+By+Cz+D=0$  ko'rinishdagi tenglama tekislikni aniqlaydi va ixtiyoriy tekislik tenglamasini

$$Ax+By+Cz+D=0$$

ko'rinishda yozish mumkin.  $A, B, C$  lar tekislikka perpendikulyar  $\vec{N}(A, B, C)$  vektorning koordinatalari. Umumiy tenglamani normal holga keltirish uchun uni normallashtiruvchi ko'paytuvchi

$$\mu = \pm \frac{1}{|N|} = \pm \frac{1}{\sqrt{A^2 + B^2 + C^2}}$$

ga ko'paytirish kerak, bu erdagi ishora  $D$  ning ishorasiga teskari bo'ladi.

$Ax+By+Cz+D=0$  umumiy tenglamaning xususiy xollari:

$A=0$ ; bu holda, tekislik  $OX$  o'qiga parallel;

$B=0$ ; bu holda, tekislik  $OY$  o'qiga parallel;

$C=0$ ; bu holda, tekislik  $OZ$  o'qiga parallel;

$D=0$ ; bu holda, tekislik koordinat boshidan o'tadi;

$A=B=0$ ; bu holda, tekislik  $OZ$  o'qiga perpendikulyar ( $XOY$  tekisligiga parallel);

$A=C=0$ ; bu holda, tekislik  $OY$  o'qiga perpendikulyar ( $XOZ$  tekisligiga parallel);

$B=C=0$ ; bu holda, tekislik  $OX$  o'qiga perpendikulyar ( $YOZ$  tekisligiga parallel);

$A=D=0$ ; bu holda, tekislik  $OX$  o'qidan o'tadi;

$B=D=0$ ; bu holda, tekislik  $OY$  o'qidan o'tadi;

$C=D=0$ ; bu holda, tekislik  $OZ$  o'qidan o'tadi;

$A=B=D=0$ ; bu holda, tekislik  $XOY$  ( $Z=0$ ) tekisligi bilan ustma-ust tushadi;

$A=C=D=0$ ; bu holda, tekislik  $XOZ$  ( $Y=0$ ) tekisligi bilan ustma-ust tushadi;



$B=C=D=0$ ; bu holda, tekislik YOZ ( $X=0$ ) tekisligi bilan ustma-ust tushadi.

Agar umumiy tenglamada  $D \neq 0$  bo'lsa, tenglamani  $-D$  ga bo'lib,

$$\frac{x}{a} + \frac{y}{b} + \frac{z}{c} = 1$$

ga ega bo'lamiz.

(bu erda,  $a=-D/A$ ,  $b=-D/B$ ,  $c=-D/C$ .) Bu tekislikning kesmalarga nisbatan tenglamasi deyiladi;  $a$ ,  $b$ ,  $c$  lar tekislikning OX, OY, OZ o'qlar bilan kesishgan nuqtalari.

$A_1x + B_1y + C_1z + D_1 = 0$  va  $A_2x + B_2y + C_2z + D_2 = 0$  tekisliklar orasidagi burchak

$$\cos \varphi = \frac{A_1A_2 + B_1B_2 + C_1C_2}{\sqrt{A_1^2 + B_1^2 + C_1^2} \cdot \sqrt{A_2^2 + B_2^2 + C_2^2}}$$

formula bilan aniqlanadi.

Ikki tekislikning parallellik sharti

$$A_1/A_2 = B_1/B_2 = C_1/C_2.$$

Perpendikulyarlik sharti

$$A_1A_2 + B_1B_2 + C_1C_2 = 0.$$

$M_0(x_0, y_0, z_0)$  nuqtadan  $Ax + By + Cz + D = 0$  tekislikkacha masofa

$$d = \frac{|Ax_0 + By_0 + Cz_0 + D|}{\sqrt{A^2 + B^2 + C^2}}$$

formula bilan aniqlanadi.

Bunda tekislikning normal tenglamasiga  $M_0(x_0, y_0, z_0)$  nuqtaning koordinatalarini qo'yib, natijaning absolyut qiymati olingan.

$M_0(x_0, y_0, z_0)$  nuqtadan o'tib,  $\vec{N} = A\vec{i} + B\vec{j} + C\vec{k}$  vektorga perpendikulyar tekislik tenglamasi

$$A(x-x_0) + B(y-y_0) + C(z-z_0) = 0$$

ko'rinishda bo'ladi.

Berilgan  $M_1(x_1, y_1, z_1)$ ,  $M_2(x_2, y_2, z_2)$ ,  $M_3(x_3, y_3, z_3)$  uch nuqtadan o'tuvchi tekislik tenglamasi

$$\begin{vmatrix} x-x_1 & y-y_1 & z-z_1 \\ x_2-x_1 & y_2-y_1 & z_2-z_1 \\ x_3-x_1 & y_3-y_1 & z_3-z_1 \end{vmatrix} = 0$$

### To'g'ri chiziq

To'g'ri chiziqni ikki tekislikning kesishgan chizig'i deb qarash mumkin:

$$\begin{cases} A_1x + B_1y + C_1z + D_1 = 0 \\ A_2x + B_2y + C_2z + D_2 = 0 \end{cases}$$

Ikki  $M_1(x_1, y_1, z_1)$ ,  $M_2(x_2, y_2, z_2)$  nuqtadan o'tuvchi to'g'ri chiziq tenglamasi:

$$\frac{x-x_1}{x_2-x_1} = \frac{y-y_1}{y_2-y_1} = \frac{z-z_1}{z_2-z_1}$$

$M_1(x_1, y_1, z_1)$  nuqtadan o'tib,  $\vec{S} = \vec{l} + m\vec{j} + n\vec{k}$  vektorga parallel to'g'ri chiziqning kanonik tenglamasi:

$$\frac{x-x_1}{l} = \frac{y-y_1}{m} = \frac{z-z_1}{n}$$

Xususiyl holda, uni quyidagicha:

$$\frac{x-x_1}{\cos\alpha} = \frac{y-y_1}{\cos\beta} = \frac{z-z_1}{\cos\gamma}$$

yo'zish mumkin, bu erda,  $\alpha, \beta, \gamma$  to'g'ri chiziqning o'qlar bilan tashkil qilgan burchaklari. To'g'ri chiziqning yo'naltiruvchi kosinuslari

$$\cos\alpha = \frac{l}{\sqrt{l^2 + m^2 + n^2}}, \quad \cos\beta = \frac{m}{\sqrt{l^2 + m^2 + n^2}}, \quad \cos\gamma = \frac{n}{\sqrt{l^2 + m^2 + n^2}}$$

formulalar bilan aniqlanadi.

Kanonik tenglamalarga  $t$  parametr kiritib, parametrik tenglamalarga kelish mumkin:

$$\begin{cases} x = lt + x_1 \\ y = mt + y_1 \\ z = nt + z_1 \end{cases}$$

Kanonik tenglamalar bilan berilgan ikki to'g'ri chiziq orasidagi burchak

$$\cos \varphi = \frac{l_1 l_2 + m_1 m_2 + n_1 n_2}{\sqrt{l_1^2 + m_1^2 + n_1^2} \cdot \sqrt{l_2^2 + m_2^2 + n_2^2}}$$

Ikki to'g'ri chiziqning parallellik sharti:

$$l_1 / l_2 = m_1 / m_2 = n_1 / n_2.$$

Ikki to'g'ri chiziqning perpendikulyarlik sharti:

$$l_1 l_2 + m_1 m_2 + n_1 n_2 = 0.$$

$(x-x_1)/l=(y-y_1)/m=(z-z_1)/n$  to'g'ri chiziq va  $Ax+By+Cz+D=0$  tekislik orasidagi burchak formulasi

$$\sin \varphi = \frac{Al + Bm + Cn}{\sqrt{A^2 + B^2 + C^2} \cdot \sqrt{l^2 + m^2 + n^2}}$$

tenglikdan topiladi.

To'g'ri chiziq va tekislikning perpendikulyarlik sharti:

$$Al+Bm+Cn=0.$$

To'g'ri chiziq va tekislikning parallellik sharti:

$$A/l=B/m=C/n.$$

$$\frac{x-x_1}{l} = \frac{y-y_1}{m} = \frac{z-z_1}{n} \text{ to'g'ri chiziqning } Ax+By+Cz+D=0$$

tekislik bilan kesishish nuqtasini topish uchun ularning tenglamasi birga echiladi, bunda to'g'ri chiziqning

$$\begin{cases} x = lt + x_0 \\ y = mt + y_0 \\ z = nt + z_0 \end{cases}$$

ko'rinishdagi parametrik tenglamasidan foydalaninsh kerak.

a) Agar  $Al+Bm+Cn \neq 0$  bo'lsa, to'g'ri chiziq tekislikni kesadi.

b) Agar  $Al+Bm+Cn=0$ ,  $Ax_0 + By_0 + Cz_0 + D \neq 0$  bo'lsa, to'g'ri chiziq tekislikka parallel.

v) Agar  $Al+Bm+Cn=0$ ,  $Ax_0 + By_0 + Cz_0 + D = 0$  bo'lsa, to'g'ri chiziq tekislikda yotadi.

### **Ikkinchi tartibli sirtlar. Sfera**

Dekart koordinata sistemasida markazi  $C(a,b,c)$  va radiusi  $r$  bo'lgan sfera

$$(x-a)^2+(y-b)^2+(z-c)^2=r^2$$

tenglama bilan aniqlanadi.

Agar markaz koordinata boshida yotsa, tenglama

$$x^2+y^2+z^2=r^2$$

ko'rinishida bo'ladi.

### **Silindrik sirtlar va ikkinchi tartibli konus**

$F(x,y)=0$  tenglama fazoda yasovchisi  $OZ$  o'qiga parallel bo'lgan silindrik sirtни ifodalaydi. Shunga o'xshash  $F(x,z)=0$  yasovchisi  $OY$  o'qiga,  $F(y,z)=0$   $OX$  o'qiga parallel bo'lgan silindrik sirtни ifodalaydi.

Ikkinchi tartibli silindrik sirtlarning kanonik tenglamalari:

$$\frac{x^2}{a^2} + \frac{y^2}{b^2} = 1 \quad \text{--elliptik silindr:}$$

$$\frac{x^2}{a^2} - \frac{y^2}{b^2} = 1 \quad \text{--giperbolik silindr:}$$

$$y^2=2px \quad \text{--parabolik silindr.}$$

Uchala silindrning yasovchilari  $OZ$  o'qiga parallel, yo'naltiruvchisi esa,  $XOY$  tekisligida yotuvchi ikkinchi tartibli egri chiziq (ellips, giperbola, parabola). Fazoda egri chiziqni ikki sirtning kesishgan chizig'i deb qarash mumkin.

Masalan, elliptik silindrning yo'naltiruvchisi, ya'ni  $XOY$  tekisligidagi ellips tenglamasi

$$\frac{x^2}{a^2} + \frac{y^2}{b^2} = 1$$

$z=0$ .

O'qi OZ, uchi koordinata boshida bo'lgan ikkinchi tartibli konus tenglamasi ushbu

$$\frac{x^2}{a^2} + \frac{y^2}{b^2} - \frac{z^2}{c^2} = 0$$

ko'rinishda bo'ladi, xuddi shunga o'xshash,

$$\frac{x^2}{a^2} - \frac{y^2}{b^2} + \frac{z^2}{c^2} = 0, \quad -\frac{x^2}{a^2} + \frac{y^2}{b^2} + \frac{z^2}{c^2} = 0$$

larning o'qlari mos ravishda OY, OX lar hisoblanadi.

### Aylanma sirt. Ikkinchi tartibli sirt

Ellips, giperbola, parabolaning o'z simmetriya o'qi atrofida aylanishidan hosil bo'lgan ikkinchi tartibli aylanma sirt tenglamalarini keltiramiz:

$\frac{x^2}{a^2} + \frac{y^2}{c^2} + \frac{z^2}{c^2} = 1$  - aylanma ellipsoid, bu erda, aylanish o'qi OZ.

$\frac{x^2}{a^2} + \frac{y^2}{c^2} - \frac{z^2}{c^2} = 1$  - aylanma bir pallali giperboloid, aylanish o'qi OZ (OZ giperbolaning mavhum o'qi).

$\frac{x^2}{a^2} + \frac{y^2}{c^2} - \frac{z^2}{c^2} = -1$  - aylanma ikki pallali giperboloid, aylanish o'qi OZ (giperbolaning haqiqiy o'qi).

$x^2 + y^2 = 2pz$  - aylanma paraboloid.

Ikkinchi tartibli aylanma sirtlar umumiy ko'rinishdagi ikkinchi tartibli sirtlarning hususiy holidir:

$$\frac{x^2}{a^2} + \frac{y^2}{b^2} + \frac{z^2}{c^2} = 1 \quad - \text{ellipsoid};$$

$$\frac{x^2}{a^2} + \frac{y^2}{b^2} - \frac{z^2}{c^2} = 1 \quad - \text{bir pallali giperboloid};$$

$$\frac{x^2}{a^2} + \frac{y^2}{b^2} - \frac{z^2}{c^2} = -1 \quad \text{- ikki pallali giperboloid;}$$

$$\frac{x^2}{p} + \frac{y^2}{q} = 2z \quad (p > 0, q > 0) \quad \text{- elliptik paraboloid.}$$

Bu to'rtta ikkinchi tartibli sirtlardan, ikkinchi tartibli uchta silindr (elliptik, giperbolik, parabolik) ikkinchi tartibli konusdan tashqari yana bitta ikkinchi tartibli sirt – giperbolik paraboloid mavjud:

$$\frac{x^2}{p} - \frac{y^2}{q} = 2z \quad (p > 0, q > 0)$$

Shunday qilib, 9 ta ikkinchi tartibli sirt mavjud.

## 2-§. MATEMATIK ANALIZGA KIRISH

### Funksiya. Asosiy elementar funksiyalar va ularning xossalari

Ratsional va irratsional sonlar haqiqiy sonlar deyiladi. Barcha haqiqiy sonlar to'plami  $R$  bilan belgilanadi. Har bir haqiqiy sonni sonlar o'qidagi nuqtada tasvirlash mumkin.

$X$  va  $Y$  ikkita bo'sh bo'lmagan to'plamlar bo'lsin. Agar  $X$  to'plamning har bir  $x$  elementiga biror aniq qoidaga asosan  $Y$  ning yagona elementi  $y$  mos kelsa, u holda,  $X$  to'plamda qiymatlar to'plami  $Y$  bo'lgan funksiya yoki akslantirish berilgan deyiladi. Buni shunday yozish mumkin:

$x \in X, X \xrightarrow{f} Y$  yoki  $f: X \rightarrow Y$ , bunda  $X$  funksiyaning aniqlanish sohasi,  $Y$  to'plam esa - funksiyaning qiymatlar to'plami deyiladi. Agar  $y$   $x$ -ning funksiyasi bo'lsa, u holda  $y=f(x)$  ko'rinishda ham yoziladi.  $f$  funksiyaning aniqlanish sohasi  $D(f)$  bilan, qiymatlar to'plami esa,  $E(f)$  bilan belgilanadi. Oddiy xollarda funksiyaning aniqlanish sohasi:  $]a, b[$  interval (ochiq oraliq), ya'ni  $a < x < b$  shartini qanoatlantiruvchi  $x$ -ning qiymatlar to'plami;  $[a, b]$  segment (kesma yoki yopiq oraliq) ya'ni  $a \leq x \leq b$  shartni

qanoatlantiruvchi  $x$  ning qiymatlar to'plami;  $]a, b[$  (ya'ni  $a < x \leq b$ ), yoki  $[a, b[$  (ya'ni  $a \leq x < b$ ) yarim interval, cheksiz interval  $[a, +\infty[$  (ya'ni  $a \leq x < \infty$ ) yoki  $]-\infty, b[$  (ya'ni  $-\infty < x \leq b$ ) yoki  $]-\infty, +\infty[$  (ya'ni  $-\infty < x < \infty$ ), bir necha intervallar va segmentlar to'plami va x.k.

Quyidagi funksiyalar asosiy elementar funksiyalar deyiladi:

1.  $u = x^{\alpha}$  darajali funksiya, bunda  $\alpha \in \mathbb{R}$

2.  $u = a^x$  ko'rsatkichli funksiya, bunda  $a$  - birdan farqli ixtiyoriy musbat son:  $a > 0, a \neq 1$

3.  $y = \log_a x$  logarifmik funksiya, bunda  $a$  - birdan farqli xar qanday musbat son:  $a > 0, a \neq 1$ .

4.  $y = \sin x, y = \cos x, y = \operatorname{tg} x, y = \operatorname{ctg} x$ , trigonometrik funksiyalar:

5.  $y = \arcsin x, y = \arccos x, y = \operatorname{arctg} x, y = \operatorname{arcctg} x$  teskari trigonometrik funksiyalar.

Elementar funksiyalar deb asosiy elementar funksiyalardan to'rt arifmetik amal va superpozitsiyalash (ya'ni murakkab funksiyalarni hosil qilish) amalini chekli son marta qo'llash yordamida hosil bo'ladigan funksiyalarga aytiladi.

Haqiqiy son  $x$  ning absolyut qiymati (moduli) elementar bo'lmagan funksiyaga misol bo'lib xizmat qiladi:

$$y = |x| = \begin{cases} x, & x \geq 0 \text{ da} \\ -x, & x < 0 \text{ da} \end{cases}$$

$|x|$  - geometrik nuqtai nazardan sonlar o'qida koordinatasi  $x$  bo'lgan nuqtadan koordinata boshigacha bo'lgan masofaga teng. Koordinatalari  $(x, f(x))$  bo'lgan XOY tekislikdagi nuqtalar to'plami  $y = f(x)$  funksiyaning grafigi deyiladi, bunda  $x \in D(f)$ .

Agar xar qanday  $x \in D(f)$  uchun  $f(-x) = f(x)$  [mos ravishda  $f(-x) = -f(x)$ ] bo'lsa, aniqlanish sohasi nolga nisbatan simmetrik bo'lgan  $f(x)$  funksiya, juft (toq) funksiya deyiladi.

Juft funksiyaning grafigi ordinata o'qiga nisbatan, toq funksiyaning grafigi - koordinata boshiga nisbatan simmetrik bo'ladi. Agar shunday musbat  $T$  son mavjud bo'lsaki,  $x \in D(f)$  va  $(x+T) \in D(f)$  da  $f(x+T) = f(x)$  tenglik bajarilsa,  $f(x)$  funksiya

davriy funksiya deyiladi. Ko'rsatilgan xossaga ega bo'lgan  $\epsilon$  kichik musbat  $\tau$  soniga funksiyaning asosiy davri deyiladi.

### Sonli ketma-ketliklar, ularning limiti

Funksiyaning nuqtadagi chekli limitining ta'rifi:

Agar ixtiyoriy kichik  $\epsilon > 0$  uchun shunday  $\delta(\epsilon) > 0$  son topilsaki,  $|x-a| < \delta$  bo'lganda,  $|f(x)-A| < \epsilon$  tengsizlik kelib chiqsa,  $x \rightarrow a$  da  $A$  soni  $f(x)$  funksiyaning limiti deyiladi va quyidagicha yoziladi:  $\lim_{x \rightarrow a} f(x) = A$ . Agar  $|x| > N$  bo'lganda  $|f(x)-A| < \epsilon$  bo'lsa  $\lim_{x \rightarrow \infty} f(x) = A$  deb yoziladi.

Agar  $\lim_{x \rightarrow a} f(x) = 0$  (yoki  $\lim_{x \rightarrow a} F(x) = \infty$ ) bo'lsa,  $f(x)$  funksiya (yoki  $F(x)$ ) cheksiz kichik (cheksiz katta) deyiladi.

$x \rightarrow a$  bo'lganda, bir vaqtda 0 yoki  $\infty$  ga intiluvchi 2 ta  $f(x)$  va  $\varphi(x)$  funksiyalar uchun  $\lim_{x \rightarrow a} \frac{f(x)}{\varphi(x)} = 1$  bo'lsa, bu funksiyalar

ekvivalent deyiladi va  $f(x) \sim \varphi(x)$  ko'rinishda yoziladi.

Elementar funksiyaning biror nuqtadagi limiti funksiyaning shu nuqtadagi qiymatiga teng:  $\lim_{x \rightarrow a} f(x) = f(a)$ .  $x \rightarrow a$  ( $a=0$  yoki  $a=\infty$ ) bo'lganda funksiyaning limitini hisoblashda quyidagi aniqlasliklarga kelish mumkin:

$$\infty - \infty, \quad \infty \cdot 0, \quad \frac{0}{0}, \quad 1^\infty, \quad 0^0, \quad \infty^0.$$

Bu aniqlasliklarni ochishning oddiy usullari:

- 1) Aniqlaslikka olib keladigan ko'paytuvchiga qisqartirish.
- 2) ( $x \rightarrow \infty$  da ko'phadlarning nisbati berilsa) surat va mahrajni argumentning eng yuqori darajasiga bo'lish.
- 3) Cheksiz kichik va cheksiz katta ekvivalentlarni qo'llash.
- 4) Ikkita ajoyib limitlardan foydalanish



$$\lim_{\alpha(x) \rightarrow 0} \frac{\sin \alpha(x)}{\alpha(x)} = 1 \quad \text{va} \quad \lim_{\alpha(x) \rightarrow 0} (1 + \alpha(x))^{\frac{1}{\alpha(x)}} = e.$$

## Funksiyaning uzluksizligi

Agar

1.  $f(x)$  funksiya  $a$  nuqtada aniqlangan;
2.  $\lim_{x \rightarrow a} f(x) = f(a)$

bo'lsa, u holda,  $f(x)$  funksiya  $a$  nuqtada uzluksiz deyiladi.

Agar  $\lim_{x \rightarrow a-0} f(x) = f(a-0)$  ( $\lim_{x \rightarrow a+0} f(x) = f(a+0)$ ) bo'lsa, u

holda,  $f(x)$  funksiya  $a$  nuqtada chapdan (o'ngdan) uzluksiz deyiladi.

Agarda funksiyaning aniqlanish sohasidagi  $a$  nuqtada uzluksizlik sharti buzilsa, bu nuqta funksiyaning uzulish nuqtasi deyiladi.

Agarda  $\lim_{x \rightarrow a-0} f(x) = f(a-0)$  va  $\lim_{x \rightarrow a+0} f(x) = f(a+0)$

limitlar mavjud bo'lib, lekin  $f(a)$ ,  $f(a-0)$ ,  $f(a+0)$  sonlar o'zaro teng bo'lmasalar bu holda  $a$  nuqta 1-tur uzulish nuqtasi deyiladi.

1-tur uzulish nuqtasi tuzatish mumkin bo'lgan uzulish nuqtasi deyiladi, agarda  $f(a-0) = f(a+0) \neq f(a)$  bo'lsa, 1-tur uzulish nuqtasi sakrash nuqtasi deyiladi agarda  $f(a-0) \neq f(a+0)$  bo'lsa  $f(a-0) - f(a+0)$  ayirmaga funksiyaning  $a$  nuqtadagi sakrash qiymati deyiladi.

1-tur uzulish nuqtasi bo'lmagan boshqa uzulish nuqtalari 2-tur uzulish nuqtalari deyiladi.

## Bir o'zgaruvchili funksiyaning differensial hisobi

$y=f(x)$  funksiyaning  $x$  bo'yicha hosilasi deb, funksiya ortirmasi  $\Delta y$  ning argument ortirmasi  $\Delta x$  ga nisbatining argument ortirmasi  $\Delta x \rightarrow 0$  dagi limitiga aytiladi va ta'rifga asosan quyidagicha yoziladi:

$$f'(x) = \lim_{\Delta x \rightarrow 0} \frac{\Delta y}{\Delta x} = \lim_{\Delta x \rightarrow 0} \frac{f(x + \Delta x) - f(x)}{\Delta x}.$$

Hosilaning geometrik ma'nosi:  $y=f(x)$  funksiya grafigiga  $x$  nuqtada o'tkazilgan urunmaning burchak koeffitsientiga teng, ya'ni  $y' = \text{tg} \alpha$ . Hosila  $y=f(x)$  funksiyaning  $x$  nuqtadagi

O'zgarish tezligidir. Hosilani topish amali funksiyani differensiallash deyiladi.

Hosilaning asosiy qoidalari:

1).  $(u \pm v)' = u' \pm v'$ . 2).  $(Cu)' = Cu'$ . 3).  $(uv)' = u'v + uv'$ .

4).  $\left(\frac{u}{v}\right)' = \frac{u'v - uv'}{v^2}$ . 5).  $f'_x[u(x)] = f'_u[u(x)] \cdot u'_x(x)$

Hosilalar jadvali:

1).  $C' = 0$ ; 2).  $x' = 1$ ;

2).  $(x^m)' = m \cdot x^{m-1}$ .

13.  $(\arcsin x)' = \frac{1}{\sqrt{1-x^2}}$ .

3.  $(\sqrt{x})' = \frac{1}{2\sqrt{x}}$ .

14.  $(\arccos x)' = -\frac{1}{\sqrt{1-x^2}}$ .

4.  $\left(\frac{1}{x}\right)' = -\frac{1}{x^2}$ .

15.  $(\operatorname{arctg} x)' = \frac{1}{1+x^2}$ .

5.  $(e^x)' = e^x$ .

16.  $(\operatorname{arcctg} x)' = -\frac{1}{1+x^2}$ .

6.  $(a^x)' = a^x \ln a$ .

17.  $(\operatorname{sh} x)' = \left(\frac{e^x - e^{-x}}{2}\right)' = \operatorname{ch} x$ .

7.  $(\ln x)' = \frac{1}{x}$ .

18.  $(\operatorname{ch} x)' = \left(\frac{e^x + e^{-x}}{2}\right)' = \operatorname{sh} x$ .

8.  $(\log_a x)' = \frac{1}{x \ln a}$ .

19.  $(\operatorname{th} x)' = \left(\frac{\operatorname{sh} x}{\operatorname{ch} x}\right)' = \frac{1}{\operatorname{ch}^2 x}$ .

9.  $(\sin x)' = \cos x$ .

20.  $(\operatorname{cth} x)' = \left(\frac{\operatorname{ch} x}{\operatorname{sh} x}\right)' = -\frac{1}{\operatorname{sh}^2 x}$ .

10.  $(\cos x)' = -\sin x$ .

11.  $(\operatorname{tg} x)' = \frac{1}{\cos^2 x}$ .

12.  $(\operatorname{ctg} x)' = -\frac{1}{\sin^2 x}$ .

## Oshkormas funksiyaning hosilasi

$F(x,y)=0$  oshkormas funksiyaning hosilasini topish uchun tenglikning ikki tomonidan  $y$ -ni  $x$ -ning funksiyasi ekanligini ko'zda tutgan holda  $x$  bo'yicha hosila olinadi va hosil bo'lgan tenglikdan  $y'$  topiladi.

### Parametrik ko'rinishda berilgan funksiyalarning hosilasi

Agar funksiya quyidagi parametrik ko'rinishda berilgan bo'lsa:

$$x=\varphi(t), y=\psi(t); \text{ u holda } y'_x = \frac{y'_t}{x'_t}.$$

### Urunma tenglamasi

Agar egri chiziq  $y=f(x)$  tenglama orqali berilgan bo'lsa, u holda,  $f'(x_0) = \operatorname{tg}\alpha$ , bu erda  $\alpha$   $OX$  o'qining musbat yo'nalishi bilan  $x_0$  nuqtada egri chiziqqa o'tkazilgan unrunma orasidagi burchak.

$y=f(x)$  egri chiziqqa  $M_0(x_0, y_0)$  nuqtada o'tkazilgan unrunma tenglamasi:  $y - y_0 = f'(x_0)(x - x_0)$ .

### Yuqori tartibli hosilalar

$y=f(x)$  funksiyaning ikkinchi tartibli hosilasi deb uning birinchi tartibli hosilasidan olingan hosilasiga aytiladi va  $y''$  bilan belgilanadi.  $y=f(x)$  funksiyaning uchinchi tartibli hosilasi deb uning ikkinchi tartibli hosilasidan olingan hosilasiga aytiladi hamda  $y'''$  bilan belgilanadi va hokazo.

Agar funksiya quyidagi parametrik ko'rinishda berilgan bo'lsa:

$$x=\varphi(t), y=\psi(t); \text{ u holda, } y''_{xx} = \frac{(y'_x)'_t}{x'_t}, \quad y'''_{xxx} = \frac{(y''_{xx})'_t}{x'_t} \text{ va}$$

hokazo.

## Lopital qoidasi

$\frac{0}{0}$  yoki  $\frac{\infty}{\infty}$  ko'rinishdagi aniqmasliklarni ochish).

2-ta cheksiz kichik miqdor yoki cheksiz katta miqdor nisbatining limiti ularning hosilalari nisbatlarining limitiga teng, ya'ni

$$\lim_{x \rightarrow a} \frac{f(x)}{\varphi(x)} = \lim_{x \rightarrow a} \frac{f'(x)}{\varphi'(x)} = A.$$

## Funksiyani tekshirish

Agar  $x_0$  nuqtaning etarli kichik atrofida  $f(x) < f(x_0)$  yoki  $f(x) > f(x_0)$  tengsizliklar bajarilsa,  $f(x)$  funksiya  $x_0$  nuqtada maksimum yoki minimumga ega bo'ladi (max. yoki min.).

Funksiyaning maksimum va minimumlari funksiyaning ekstremumlari deyiladi. Ekstremumning zaruriy sharti: agar  $x_0$   $f(x)$  funksiyaning ekstremum nuqtasi bo'lsa, u holda,  $f'(x_0) = 0$ , yoki bu nuqtada hosila mavjud bo'lmaydi.

Ekstremumning etarli sharti: agar  $f'(x)$   $x_0$  nuqtaning chap tomonidan o'ng tomoniga o'tishda o'z ishorasini musbatdan manfiyga o'zgartirsa, shu nuqtada funksiya maksimumga ega bo'ladi, agar chapdan o'ngga o'tishda  $f'(x)$  ning ishorasi manfiydan musbatga o'zgarsa, funksiya shu nuqtada minimumga ega bo'ladi.

Agar  $(a,b)$  ning hamma nuqtalarida  $f''(x) < 0$  bo'lsa, shu intervalda  $y = f(x)$  funksiyaning grafigi qavariq bo'ladi, agar  $(a,b)$  ning hamma nuqtalarida  $f''(x) > 0$  bo'lsa, shu intervalda  $y = f(x)$  funksiyaning grafigi botiq bo'ladi. Uzluksiz funksiya

grafigining qavariq qismini botiq qismidan ajratgan nuqta burilish nuqtasi bo'ladi, bu nuqtada  $f''(x) = 0$  bo'ladi.

$y=kx+b$  to'g'ri chiziq  $y=f(x)$  funksiya grafigining og'ma asimptotasi deyiladi. Bu erda,

$$k = \lim_{x \rightarrow \infty} \frac{f(x)}{x}, \quad b = \lim_{x \rightarrow \infty} (f(x) - kx).$$

$k=0$  bo'lganda  $y=b$  bo'ladi, bu gorizontal asimptota deyiladi. Agar  $\lim_{x \rightarrow a-0} f(x) = \infty$  yoki  $\lim_{x \rightarrow a+0} f(x) = \infty$  bo'lsa,  $x=a$  to'g'ri chiziq vertikal asimptota deyiladi.

### 3-§. BIR O'ZGARUVCHILI FUNKSIYANING INTEGRALI

#### Aniqmas integral

Agar  $F'(x) = f(x)$  bo'lsa,  $F(x)$  funksiya  $f(x)$  funksiyaning boshlang'ich funksiyasi deyiladi. ~~Agar  $F(x)$  funksiya  $f(x)$~~  funksiyaning boshlang'ich funksiyasi bo'lsa,  $u$  holda,  $F(x) + C$  ham boshlang'ich funksiyasidir.  $f(x)$  funksiyaning aniqmas integrali deb uning barcha boshlang'ichlari to'plamiga aytiladi va quyidagicha belgilanadi:  $\int f(x)dx = F(x) + C$ .

#### Integrallash qoidalari:

1.  $(\int f(x)dx)' = f(x)$ .
2.  $d(\int f(x)dx) = f(x)dx$ .
3.  $\int dF(x) = F(x) + C$ .
4.  $\int af(x)dx = a \int f(x)dx$ .
5.  $\int [f_1(x) \pm f_2(x)]dx = \int f_1(x)dx \pm \int f_2(x)dx$ .
6. Agar  $\int f(x)dx = F(x) + C$  va  $u = \varphi(x)$  bo'lsa,  $u$  holda,  $\int f(u)du = F(u) + C$ .

## Aniqmas integrallar jadvali

I.  $\int dx = x + C.$

VIII.  $\int \sin x dx = -\cos x + C.$

II.  $\int x^m dx = \frac{x^{m+1}}{m+1} + C \quad m \neq -1.$

IX.  $\int \cos x dx = \sin x + C.$

III.  $\int \frac{dx}{x} = \ln|x| + C.$

X.  $\int \frac{1}{\sin^2 x} dx = \operatorname{tg} x + C.$

IV.  $\int \frac{dx}{1+x^2} = \operatorname{arctg} x + C.$

XI.  $\int \frac{1}{\cos^2 x} dx = -\operatorname{ctg} x + C.$

V.  $\int \frac{dx}{\sqrt{1-x^2}} = \operatorname{arcsin} x + C.$

XII.  $\int \operatorname{sh} x dx = \operatorname{ch} x + C.$

VI.  $\int e^x dx = e^x + C.$

XIII.  $\int \operatorname{ch} x dx = \operatorname{sh} x + C$

VII.  $\int a^x dx = \frac{a^x}{\ln a} + C.$

Ixtiyoriy funksiyalarni integrallashda quyidagi usullardan foydalaniladi:

1. Agar  $\int f(x) dx = F(x) + C$  bo'lsa,  $u$  holda,

$$\int f(ax + b) dx = \frac{1}{a} F(ax + b) + C \text{ bo'ladi, bu erda, } a \text{ va } b \text{ lar}$$

ixtiyoriy o'zgarmaslar.

2. Differensial ostiga kiritish:

$$\int f[\varphi(x)] \cdot \varphi'(x) dx = \int f[\varphi(x)] \cdot d[\varphi(x)] = \int f(u) du \quad \text{chunki}$$

$$\varphi'(x) dx = d\varphi(x), \quad [u = \varphi(x)].$$

3. Bo'laklab integrallash formulasi:  $\int u dv = uv - \int v du.$

Odatda,  $dv$  ifoda integrallashda qiyinchilik tug'dirmaydigan qilib tanlab olinadi. Bo'laklab integrallanadigan funksiyalar sinfiga, xususan:

$$P(x) \cdot e^{\alpha x}, \quad P(x) \cdot \sin \alpha x, \quad P(x) \cdot \cos \alpha x, \quad P(x) \cdot \ln x,$$

$P(x) \cdot \arcsin x$ ,  $P(x) \cdot \arctg x$  lar kiradi, bu erda,  $P(x)$  – ko'phad.

4. Ratsional kasrlarni integrallash:

$R(x) = \frac{P(x)}{Q(x)}$  ko'phadlar nisbati berilgan bo'lsa,  $R(x)$

elementar kasrlarga ajratiladi:

ular  $\frac{A}{(x-a)^m} + \frac{Mx+N}{x^2+px+q}$  ko'rinishda bo'lib, bu erda

$m$  butun musbat son.

$$\int \frac{A}{x-a} dx = A \ln|x-a| + C;$$

$$\int \frac{A dx}{(x-a)^m} = -\frac{A}{m-1} \cdot \frac{1}{(x-a)^{m-1}} + C; \quad m \neq 1.$$

$$\int \frac{dx}{x^2+px+q} = \frac{2}{\sqrt{4q-p^2}} \cdot \arctg \frac{2x+p}{\sqrt{4q-p^2}} + C.$$

5. O'zgaruvchilarni almashtirish usuli:

Bu usulning ma'nosi  $x$  o'zgaruvchidan  $t$  o'zgaruvchiga o'tish:

$x=f(t)$ . Ko'p uchraydigan funksiyalarga standart almashtirishlar ko'rsatish mumkin.

$$\int R\left(x, \sqrt{\frac{ax+b}{cx+d}}\right) dx, \quad \sqrt{\frac{ax+b}{cx+d}} = t;$$

$$\int R(x, \sqrt{a^2-x^2}) dx, \quad x = a \cdot \sin t;$$

$$\int R(x, \sqrt{a^2+x^2}) dx, \quad x = a \cdot \operatorname{tg} t;$$

$$\int R(x, \sqrt{x^2-a^2}) dx, \quad x = \frac{a}{\sin t};$$

$$\int R(\sin x, \cos x) dx, \quad \operatorname{tg}\left(\frac{x}{2}\right) = t;$$

bu erda,  $R$  – ratsional funksiyaning simvoli.

## Aniq integral

Agar  $F'(x) = f(x)$  va  $F(x)$  boshlang'ich  $[a, b]$  kesmada uzluksiz bo'lsa, aniq integralni hisoblashda Nyuton-Leybnis formulasi

$$\int_a^b f(x) dx = F(b) - F(a)$$

ko'rinishda bo'ladi. Aniq integral  $x=a$ ,  $x=b$ ,  $y=0$  to'g'ri chiziqlar va  $y=f(x)$  funksiya grafigi bilan chegaralangan trapetsiyaning yuziga teng, agar  $f(x) \geq 0$  bo'lsa, «+» ishora bilan,  $f(x) \leq 0$  bo'lsa, «-» ishora bilan olinadi.

## Xosmas integrallar.

### Chegarasi cheksiz xosmas integrallar

Agar  $\lim_{b \rightarrow +\infty} \int_a^b f(x) dx$  limit mavjud bo'lsa, bu limit  $f(x)$

funksiyaning  $[a, +\infty)$  dagi xosmas integrali deyiladi va

$$\int_a^{+\infty} f(x) dx = \lim_{b \rightarrow +\infty} \int_a^b f(x) dx \quad \text{ko'rinishda yoziladi.}$$

Xuddi shuningdek, agar  $\lim_{a \rightarrow -\infty} \int_a^b f(x) dx$  limit mavjud bo'lsa,

bu limit  $f(x)$  funksiyaning  $(-\infty, b]$  dagi xosmas integrali

deyiladi va  $\int_{-\infty}^b f(x) dx = \lim_{a \rightarrow -\infty} \int_a^b f(x) dx$  ko'rinishda yoziladi. Agar

o'ng tomonda turgan limit chekli bo'lsa, u holda integral yaqinlashuvchi xosmas integral deyiladi, aks holda, integral uzoqlashuvchi deyiladi.

### Cheksiz funksiylarning xosmas integrallari

$f(x)$  funksiya  $a \leq x < c$  oraliqda aniqlangan va uzluksiz bo'lsin,  $x=c$  bo'lganda esa yoki aniqlanmagan, yoki uzilishga



ega bo'lsin. Bunday holda,  $f(x)$  funksiyaning  $a \leq x < c$  oraliqdagi integrali 
$$\int_a^c f(x) dx = \lim_{\varepsilon \rightarrow 0} \int_a^{c-\varepsilon} f(x) dx$$
 ko'rinishda yoziladi.

Agar  $f(x)$  funksiya  $(a, c)$  ning chap uchida uzlukli bo'lsa, u holda 
$$\int_a^c f(x) dx = \lim_{\varepsilon \rightarrow 0} \int_{a+\varepsilon}^c f(x) dx.$$

Agar o'ng tomonda turgan limit chekli bo'lsa, u holda, integral yaqinlashuvchi xosmas integral deyiladi, aks holda integral uzoqlashuvchi deyiladi. Agar  $f(x)$  funksiya  $[a, c]$  kesma ichidagi biror  $x_0$  nuqtada uzlukli bo'lsa, u holda, integral ikki integral yig'indisi ko'rinishda yoziladi:

$$\int_a^c f(x) dx = \int_a^{x_0} f(x) dx + \int_{x_0}^c f(x) dx.$$

#### 4-§. KO'P O'ZGARUVCHILI FUNKSIYALAR

1. Agar biror  $D$  to'planning har bir  $(x_1, x_2, \dots, x_n)$  elementiga biror qoida bilan  $E$  to'plamdagi yagona  $u$  haqiqiy son mos qo'yilgan bo'lsa, u holda,  $D$  to'plamda  $n$  o'zgaruvchining funksiyasi aniqlangan deyiladi va quyidagicha yoziladi:  $u = u(x_1, x_2, \dots, x_n)$ .

2.  $M(x_1, x_2, \dots, x_n)$  nuqta funksiyaning aniqlanish sohasida  $M_0(x_0, x_0, \dots, x_0)$  nuqtaga ixtiyoriy usulda intilganda

$$\lim_{M \rightarrow M_0} u(M) = u(M_0)$$

tenglik o'rinli bo'lsa,  $u = u(x_1, x_2, \dots, x_n)$  funksiya  $M_0(x_0, x_0, \dots, x_0)$  nuqtada uzluksiz deyiladi.

3.  $u = u(x_1, x_2, \dots, x_n)$  funksiyaning  $x_1$  o'zgaruvchi bo'yicha xususiy hosilasi

$$\frac{\partial u}{\partial x_1} = \lim_{\Delta x_1 \rightarrow 0} \frac{\Delta_{x_1} u}{\Delta x_1} = \lim_{\Delta x_1 \rightarrow 0} \frac{u(x_1 + \Delta x_1, x_2, \dots, x_n) - u(x_1, x_2, \dots, x_n)}{\Delta x_1}$$

tenglik bilan aniqlanadi.

Xuddi shuningdek, qolgan argumentlar bo'yicha ham xususiy hosilalar topiladi.

$$4. \frac{\partial^n u}{\partial x_{i_1}^{k_1} \partial x_{i_2}^{k_2} \dots \partial x_{i_m}^{k_m}}$$

ifoda  $n$  - tartibli xususiy hosilaning umumiy formulasi, bu erda  $k_1+k_2+\dots+k_m=n$  va  $1 \leq i_j \leq n$ ,  $1 \leq j \leq m$ .

## 5-§. ODDIY DIFFERENSIAL TENGLAMALAR

1. Erkli o'zgaruvchi  $x$ , noma'lum funksiya  $y$  va uning hosilalari  $y'$ ,  $y''$ , ...,  $y^{(n)}$  lar orasidagi bog'lanishga differensial tenglama deyiladi va quyidagi ko'rinishda yoziladi:

$$F(x, y, y', y'', \dots, y^{(n)}) = 0.$$

Birinchi tartibli differensial tenglama  $F(x, y, y') = 0$  ko'rinishda yoziladi. Bu tenglamaning  $x=x_0$  dagi  $y=y_0$  boshlang'ich shartni qanoatlantiruvchi xususiy yechimini topish masalasi Koshi masalasi deyiladi.

Berilgan differensial tenglama  $y=\varphi(x)$  yechimining XOY tekislikda chizilgan grafigi bu tenglamaning integral egri chizig'i deyiladi.

2.  $y' + P(x)y = Q(x)$  ko'rinishdagi tenglama birinchi tartibli chizikli differensial tenglama deyiladi. Agar  $Q(x) = 0$  bo'lsa, bir jinsli, agar  $Q(x) \neq 0$  bo'lsa, bir jinsli bo'lmagan differensial tenglama deyiladi. Bir jinsli tenglamaning umumiy yechimi o'zgaruvchilarni ajratish yo'li bilan topiladi. Bir jinsli bo'lmagan tenglamaning umumiy yechimi esa bir jinsli tenglamaning umumiy yechimidan ixtiyoriy o'zgarmas  $C$  ni variatsiyalash yordamida topiladi yoki  $y = u \cdot v$  ko'rinishda almashtirish yordamida topiladi.

3.  $y^{(n)} = f(x, y', \dots, y^{(n-1)})$  tenglama  $n$ -tartibli differensial tenglama bo'lib, uning  $y(x_0) = y_0$ ;  $y'(x_0) = y_0'$ ; .....  $y^{(n-1)}(x_0) = y_0^{(n-1)}$  boshlang'ich shartlarni qanoatlantiruvchi  $y=\varphi(x)$  yechimini topish masalasi Koshi masalasi deyiladi.  $n$ -tartibli differensial tenglamaning umumiy yechimi  $y = \varphi(x, C_1, C_2, \dots, C_n)$  ko'rinishda bo'ladi.

4) O'zgarmas koeffitsientli, n-tartibli, chiziqli, bir jinsli differensial tenglama berilgan bo'lsin:

$$y^{(n)} + a_1 y^{(n-1)} + \dots + a_n y = 0,$$

bu erda,  $a_1, a_2, \dots, a_n$  -lar o'zgarmas sonlar.

Bu tenglamaning umumiy yechimini topish uchun uning fundamental yechimlar sistemasini topish etarli. n - tartibli differensial tenglama bo'lgan holda fundamental sistema n ta chiziqli erkli xususiy yechimlardan iborat bo'ladi. Umumiy yechim  $y_1, y_2, \dots, y_n$  chiziqli erkli xususiy yechimlarning chiziqli kombinatsiyasi sifatida yoziladi:  $y = c_1 y_1 + c_2 y_2 + \dots + c_n y_n$ .

5)  $y^{(n)} + a_1 y^{(n-1)} + a_2 y^{(n-2)} + \dots + a_n y = f(x)$  n-tartibli, o'zgarmas koeffitsientli, bir jinsli bo'lmagan chiziqli tenglama berilgan bo'lsin. Bu tenglamaga mos bir jinsli o'zgarmas koeffitsientli  $y^{(n)} + a_1 y^{(n-1)} + a_2 y^{(n-2)} + \dots + a_n y = 0$  tenglamaning umumiy yechimi  $\tilde{y}$  bo'lsin. U holda o'zgarmas koeffitsientli, bir jinsli

bo'lmagan tenglamaning umumiy yechimi  $y = \tilde{y} + y^0$  ko'rinishda izlanadi, bu erda,  $y^0$  - bir jinsli bo'lmagan tenglamaning xususiy yechimi. O'zgarmas koeffitsientli, bir jinsli bo'lmagan tenglamaning xususiy yechimini topish uchun, noaniq koeffitsientlar usulini qo'llaymiz. Bu usul o'ng tomoni maxsus ko'rinishda bo'lgan tenglamalar uchun tatbiq qilinadi. Bunda xususiy yechimni o'ng tomonning shakliga o'xshash shaklda izlash kerak.

$$6) \begin{cases} \frac{dx}{dt} = f(t, x, y) \\ \frac{dy}{dt} = \varphi(t, x, y) \end{cases}$$

ko'rinishdagi sistemaga differensial tenglamalarning normal sistemasi deyiladi, bu erda,  $x$  va  $y$  lar noma'lum funksiyalar.

O'zgarmas koeffitsientli 2-ta chiziqli differensial tenglamalar sistemasi quyidagi ko'rinishga ega:

$$\begin{cases} \frac{dx}{dt} = a_{11}x + a_{12}y \\ \frac{dy}{dt} = a_{21}x + a_{22}y \end{cases}$$

bu erda,  $a_{ij}$  - lar o'zgarmas sonlar.

Bu sistemani matrisa ko'rinishda quyidagicha:

$$\frac{dX}{dt} = A \cdot X$$

yo'zish mumkin, bu yerda,

$$A = \begin{pmatrix} a_{11} & a_{12} \\ a_{21} & a_{22} \end{pmatrix}, \quad X = \begin{pmatrix} x \\ y \end{pmatrix}, \quad \frac{dX}{dt} = \begin{pmatrix} \frac{dx}{dt} \\ \frac{dy}{dt} \end{pmatrix}.$$

Sistemaning yechimini  $x = p_1 e^{\lambda t}$ ;  $y = p_2 e^{\lambda t}$  ko'rinishda qidiramiz.  $x$  va  $y$  qiymatlarni tenglamalar sistemasiga qo'yib,  $p_1$ ,  $p_2$  larga nisbatan chiziqli algebraik tenglamalar sistemasini hosil qilamiz:

$$\begin{cases} (a_{11} - \lambda)p_1 + a_{12}p_2 = 0 \\ a_{21}p_1 + (a_{22} - \lambda)p_2 = 0 \end{cases}$$

Bu sistema noldan farqli yechimlarga ega bo'lishi uchun uning determinanti nolga teng bo'lishi kerak:

$$\begin{vmatrix} a_{11} - \lambda & a_{12} \\ a_{21} & a_{22} - \lambda \end{vmatrix} = 0$$

Bu esa  $\lambda$  ga nisbatan 2-tartibli algebraik tenglama. Uning ildizlari haqiqiy, har xil, kompleks, karrali bo'lishi mumkin.

Ularning qiymatlariga qarab  $A$  matritsaning xos vektorlari topiladi va ular orqali berilgan sistemaning umumiy yechimlari yoziladi.

## 6-§. SONLI VA FUNKSIONAL QATORLAR

1.  $u_1 + u_2 + \dots + u_n + \dots = \sum_{n=1}^{\infty} u_n$  sonli qator deyiladi.

Agar  $S_n = \sum_{k=1}^n u_k$  qisman yig'indining limiti  $S = \lim_{n \rightarrow \infty} S_n$

mavjud bo'lsa, sonli qator yaqinlashuvchi deyiladi va  $S$ -soni qatorning yig'indisi deyiladi. Agar limit mavjud bo'lmasa,

berilgan sonli qator uzoqlashuvchi deyiladi.  $\lim_{n \rightarrow \infty} u_n = 0$  sonli qator yaqinlashuvchi bo'lishining zaruriy shartidir.

Musbat hadli sonli qatorlar yaqinlashishining etarli shartlari ( $u_n \geq 0$ ):

a) Agar  $\lim_{n \rightarrow \infty} \frac{u_n}{v_n} = k$ , ( $k \neq 0, \infty$ ) bo'lsa, u holda,  $\sum_{n=1}^{\infty} u_n$

va  $\sum_{n=1}^{\infty} v_n$  qatorlar bir vaqtda yaqinlashuvchi va uzoqlashuvchi bo'ladi.

Musbat hadli sonli qatorlar odatda, quyidagi qator

bilan taqqoslanadi:  $\sum_{n=1}^{\infty} \frac{1}{n^\alpha}$  -  $\alpha > 1$  bo'lganda yaqinlashuvchi

va  $\alpha \leq 1$  bo'lganda uzoqlashuvchi qator bo'ladi.

b) Dalamber alomati:

$\lim_{n \rightarrow \infty} \frac{u_{n+1}}{u_n} = q$  bo'lsa,  $\sum_{n=1}^{\infty} u_n$  qator  $q < 1$  bo'lganda

yaqinlashuvchi,  $q > 1$  bo'lganda uzoqlashuvchi bo'ladi. Agar  $q = 1$  bo'lsa, qatorning yaqinlashishini bu alomat bilan aniqlab bo'lmaydi.

Xuddi shunga o'xshash, Koshi alomati mavjud. Bundan tashqari integral alomati bilan ham qatorning yaqinlashuvchiligi tekshiriladi.

2.  $u_1(x) + u_2(x) + \dots + u_n(x) + \dots$  ko'rinishdagi qatorga funksional qator deyiladi,  $a_0 + a_1x + a_2x^2 + \dots + a_nx^n + \dots$  qator darajali qator deyiladi.  $a_n$ -lar qatorning koeffitsientlari. Darajali qatorning yaqinlashish sohasi markazi koordinatalar boshida bo'lgan intervaldan iborat.  $-R$  dan  $+R$  gacha bo'lgan intervalga darajali qatorning yaqinlashish intervali deyiladi, bu interval ichida yotgan har qanday  $x$  nuqtada qator yaqinlashadi, shu bilan birga absolyut yaqinlashadi, uning tashqarisidagi  $x$  nuqtalarda qator uzoqlashadi,  $R$  - darajali qatorning yaqinlashish radiusi deyiladi va

$$R = \lim_{n \rightarrow \infty} \left| \frac{u_n}{u_{n-1}} \right|$$

formula bilan hisoblanadi. Darajali qatorlarni yaqinlashish intervali ichida hadlab differensiallash va integrallash mumkin.

3.  $2\ell$  davrli  $f(x)$  funksiya uchun Fure qatori:

$$f(x) = \frac{a_0}{2} + \sum_{n=1}^{\infty} a_n \cos \frac{n\pi x}{\ell} + b_n \sin \frac{n\pi x}{\ell},$$

bu erda,

$$a_n = \frac{1}{\ell} \int_{-r}^r f(x) \cos \frac{n\pi x}{\ell} dx, \quad n=1,2,3,\dots$$

$$b_n = \frac{1}{\ell} \int_{-r}^r f(x) \sin \frac{n\pi x}{\ell} dx, \quad n=1,2,3,\dots$$

Juft funksiya uchun Fure qatori:

$$f(x) = \frac{a_0}{2} + \sum_{n=1}^{\infty} a_n \cos \frac{n\pi x}{\ell}; \quad b_n=0, \quad a_n = \frac{2}{\ell} \int_0^r f(x) \cos \frac{n\pi x}{\ell} dx,$$

Toq funksiyalar uchun Fure qatori:

$$f(x) = \sum_{n=1}^{\infty} b_n \sin \frac{n\pi x}{\ell}; \quad a_n=0, \quad b_n = \frac{2}{\ell} \int_0^r f(x) \sin \frac{n\pi x}{\ell} dx, .$$

## 7-§. KARRALI, EGRI CHIZIQLI INTEGRALLAR

1.  $\iint_D f(x,y) dx dy$  ifodaga ikki o'lchovli integral deyiladi.

Agar  $D$  soha  $a \leq x \leq b$ ,  $f_2(x) \leq y \leq f_1(x)$  da o'zgarsa, ikki o'lchovli integralni hisoblash

$$\iint_D f(x,y) dx dy = \int_a^b dx \int_{f_2(x)}^{f_1(x)} f(x,y) dy$$

ko'rinishdagi ikki karrali integralni hisoblashga olib kelinadi.

Agar D soha  $c \leq y \leq d$ ,  $\varphi_2(y) \leq x \leq \varphi_1(y)$  da o'zgarsa, ikki o'lchovli integralni hisoblash 
$$\iint_D f(x,y) dx dy = \int_c^d dy \int_{\varphi_2(y)}^{\varphi_1(y)} f(x,y) dx$$

ko'rinishdagi ikki karrali integralni hisoblashga olib kelinadi.

$$\int_c^d dy \int_{\varphi_2(y)}^{\varphi_1(y)} f(x,y) dx = \int_{\alpha}^{\beta} dx \int_{\varphi_2(x)}^{\varphi_1(x)} f(x,y) dy. \text{ Bu erda } y = \varphi_{1,2}^{-1}(x)$$

funksiya  $x = \varphi_{1,2}(y)$  funksiyaga teskari funksiyadir.

Bu tenglik bilan integrallash tartibini o'zgartirish mumkin.

2.  $\Omega$  sohada aniqlangan  $f(x,y,z)$  funksiyadan olingan uch o'lchovli integralni hisoblash

$$\iiint_{\Omega} f(x,y,z) dx dy dz = \iint_{\Omega_{xy}} dx dy \int_{\psi_1(x,y)}^{\psi_2(x,y)} f(x,y,z) dz \text{ ko'rinishdagi}$$

integralni hisoblashga keltiriladi, bu erda,  $\Omega_{xy}$   $\Omega$  - sohaning

XOY-tekislikdagi proeksiyasi,  $z = \psi_1(x,y)$  va  $z = \psi_2(x,y)$  lar  $\Omega$  soxani yuqoridan va pastdan chegaralagan sirtlar tenglamalari. Ikki o'lchovli integralga o'xshash uch o'lchovli integralda ham integrallash tartibini o'zgartirish mumkin.

3. Birinchi tur egri chiziqli integral  $\int_{(\ell)} f(x,y,z) ds$  berilgan

bo'lib, agar  $\ell$  egri chiziq  $x=x(t)$ ,  $y=y(t)$ ,  $z=z(t)$  ( $\alpha \leq t \leq \beta$ ) parametrik holda berilgan bo'lsa, unda,

$$\int_{(\ell)} f(x,y) ds = \int_{\alpha}^{\beta} f(x(t), y(t), z(t)) \cdot \sqrt{x'^2(t) + y'^2(t) + z'^2(t)} dt$$

bo'ladi.

Ikkinchi tur egri chiziqli integral

$\int P(x,y,z) dx + Q(x,y,z) dy + R(x,y,z) dz$  berilgan bo'lib, agar (L)

L-egri chiziq  $x=x(t)$ ,  $y=y(t)$ ,  $z=z(t)$  ( $\alpha \leq t \leq \beta$ ) parametrik holda berilgan bo'lsa, u holda

$$\int_{(L)} P(x, y, z)dx + Q(x, y, z)dy + R(x, y, z)dz =$$

$$= \int_{\alpha}^{\beta} P(x(t), y(t), z(t))x'(t)dt + Q(x(t), y(t), z(t))y'(t)dt +$$

$$+ R(x(t), y(t), z(t))z'(t)dt$$

bo'ladi.

4. Uch o'lchovli integrallar yordamida:

a) jismning  $V$  hajmi va uning  $M$  massasi quyidagi formula yordamida hisoblanadi:

$$M = \iiint_{\Omega} \mu(x, y, z) dx dy dz, \quad V = \iiint_{\Omega} dx dy dz, \quad \text{bu erda, } \mu$$

jism massasining zichligi;

b) bir jinsli jism inersiya momenti (masalan, OZ o'qi bo'yicha) quyidagi formula yordamida hisoblanadi:

$$J_z = \iiint_{\Omega} (x^2 + y^2) dx dy dz.$$

## 8-§. KOMPLEKS O'ZGARUVCHILI FUNKSIYALAR NAZARIYASI

Agar xar bir  $z=x+iy$  kompleks songa biror qonun yordamida bir yoki bir necha kompleks son  $w=u+iv$  mos qo'yilgan bo'lsa,

$$w = f(z) = u+iv = u(x, y) + iv(x, y)$$

kompleks o'zgaruvchili funksiya berilgan deyiladi.

Agar  $w = f(z)$  funksiya uzluksiz hosilaga ega bo'lsa, bu funksiyani analitik deyishadi. Analitiklikni tekshirish uchun quyidagi etarli va zaruriy shart mavjud:

$$\frac{\partial u(x, y)}{\partial x} = \frac{\partial v(x, y)}{\partial y}, \quad \frac{\partial u(x, y)}{\partial y} = -\frac{\partial v(x, y)}{\partial x}$$

Bu shartlar bajarilganda hosila quyidagi formula yordamida topiladi:

$$f'(z) = \frac{\partial u}{\partial x} + i \frac{\partial v}{\partial x} = \frac{\partial v}{\partial y} - i \frac{\partial u}{\partial y} = \frac{\partial u}{\partial x} - i \frac{\partial u}{\partial y} = \frac{\partial v}{\partial y} + i \frac{\partial v}{\partial x}$$



## 9-§. EHTIMOLLAR NAZARIYASI

Ehtimollar nazariyasining asosiy tushunchalaridan biri bo'lmish hodisa deb sinov (tajriba) o'tkazish natijasida, ya'ni malum shartlar majmui amalga oshishi natijasida ro'y berishi mumkin bo'lgan har qanday faktga aytiladi. Tajribaning natijasi bir qiymatli aniqlanmagan hollarda hodisa – tasodifiy hodisa deb ataladi, tajriba esa tasodifiy tajriba deb ataladi. Tasodifiy tajribalar haqida so'z yuritganimizda biz faqat etarlicha ko'p marta takrorlash mumkin bo'lgan (hech bo'lmaganda nazari jihatdan) tajribalarni ko'zda tutamiz. Tasodifiy tajribaning matematik modelini qurish quyidagi etaplarni o'z ichiga oladi:

a) elementar hodisalar to'plami  $\Omega$  - ni tuzish;

b) berilgan tajriba uchun etarli bo'lgan hodisalar sinfi  $\mathcal{R}$  ni ajratish;

v) **shu hodisalar sinfi ustida ma'lum shartlarni qanoatlantiruvchi sonli funksiya  $P$  – hodisaning ehtimolini berish.**

Hosil bo'lgan  $(\Omega, \mathcal{R}, P)$  - uchlikni ehtimollar fazosi deb ataymiz.  $\Omega$  - elementar hodisalar to'plami deb berilgan tasodifiy tajribada ro'y berishi mumkin bo'lgan barcha bir-birini rad etuvchi hodisalar to'plamiga aytiladi.  $\Omega$  - ning elementlari  $\omega_i, i=1,2,..,n$  bilan belgilanadi.  $n$  – esa  $\Omega$  - to'plam elementlarining soni.

Ehtimollik hodisadan olingan sonli funksiya. Haqiqiy o'zgaruvchili funksiyalar argumentining barcha qiymatlarida aniqlangan bo'lishi shart bo'lmaganligi kabi,  $\Omega$  to'plamning ixtiyoriy to'plam ostlari uchun ehtimolni aniqlash har doim xam mumkin bo'lmaydi. To'plam ostlari sinflarini cheklashga to'g'ri kelgan hollarda, biz bu sinflardan hodisalar ustidagi amallarga nisbatan yopiqligini talab etamiz.

$\mathcal{R}$  hodisalar sinfini shu shartlarni nazarda tutgan holda,  $\Omega$  to'plamning to'plam ostlaridan tuzamiz.

$P$  ehtimollik tasodifiy hodisadan olingan sonli funksiya bo'lib, u hodisaning ro'y berish imkonining obektiv darajasining sonli xarakteristikasidir.

Murakkab hodisa yoki oddiygina hodisa deb  $\Omega$  - elementar hodisalar to'plamining ixtiyoriy to'plam ostiga aytiladi.

Hodisalar uch turga ajratiladi: muqarrar, ro'y bermaydigan va tasodifiy hodisalar.

2. Ehtimolning klassik ta'rifi: A hodisaning ehtimoli deb, tajribaning bu hodisani ro'y berishiga qulaylik tug'diruvchi elementar hodisalari soni  $m$  ning, tajribaning barcha mumkin bo'lgan teng imkoniyatli elementar hodisalari soni  $n$  ga nisbatiga aytamiz:

$$P(A) = \frac{m}{n}.$$

8. Hodisaning nisbiy chastotasi:

Hodisa ro'y bergan natijalar sonining aslida o'tkazilgan jami tajribalar soniga nisbatiga hodisaning nisbiy chastotasi deyiladi:

$$W(A) = \frac{M}{N}$$

bu erda,  $M$  – hodisalarning ro'y berish soni;

$N$  – tajribalarning jami soni.

8. Ehtimolning geometrik ta'rifi:

$\Omega$  -  $n$  o'lchovli Evklid fazosining cheklangan to'plami oo'lsin. Hodisa deb  $\Omega$  ning o'lchovini aniqlab bo'ladigan to'plam ostini qaraymiz.  $\mathfrak{R}$  deb  $\Omega$  ning barcha o'lchovga ega bo'lgan to'plam ostlari sinfini belgilaymiz. U holda  $A$  hodisaning ehtimoli deb quyidagiga aytamiz:

$$P(A) = \frac{\mu(A)}{\mu(\Omega)},$$

bu erda,  $\mu(A)$  –  $A$  to'plamning o'lchami. ( $n=1$  bo'lganda uzunlik,  $n=2$  bo'lganda yuza,  $n=3$  bo'lganda hajm).

8. Shartli ehtimollik:

$A$  hodisaning  $B$  hodisa ro'y berdi degan shart ostida hisoblangan ehtimolligi  $A$  hodisaning  $P(B) > 0$  dagi shartli ehtimolligi deb ataladi va  $P(A/B)$  bilan belgilanadi:

$$P(A/B) = \frac{P(AB)}{P(B)}.$$

Bundan esa ehtimolliklarni ko'paytirish formulasi kelib chiqadi:

$$P(AB) = P(B)P(A/B).$$

8. To'la ehtimollik formulasi.

$A_1, A_2, \dots, A_n$  lar birgalikda bo'lmagan hodisalarning to'la guruhini tashkil etsin va barcha  $k$ -lar uchun  $R(A_k) > 0$  bo'lsin.  $U$  holda,

$$P(B) = \sum_{k=1}^n P(A_k) \cdot P(B/A_k).$$

8. Hodisalarning bog'liqsizligi:

Agar  $P(B) > 0$  va  $P(A/B) = P(A)$  bo'lsa  $A$  hodisa  $B$  hodisaga bog'liq emas deyiladi. Bundan esa, o'zaro bog'liq bo'lmagan  $A$  va  $B$  hodisalar uchun  $P(AB) = P(A)P(B)$  tenglik kelib chiqadi.

8.  $P_n(k) = \frac{n!}{k!(n-k)!} p^k q^{n-k}$  Bernulli formulasi. Bu erda

$P_n(k)$  –  $A$  hodisaning  $n$ -ta tajribada  $k$ - marta ro'y berish ehtimoli,  $p$ -esa  $A$  hodisaning bitta tajribada ro'y berish ehtimoli:  $q=1-p$ .

9. Diskret tasodifiy miqdor deb, ko'pi bilan sanoqli sondagi qiymatlarni ma'lum ehtimollik bilan qobul qiladigan miqdorga aytiladi. Uzlüksiz tasodifiy miqdor deb, chekli yoki cheksiz oraliqdagi barcha qiymatlarni qobul qilishi mumkin bo'lgan miqdorga aytiladi. Tasodifiy miqdorning qobul qiladigan qiymatlari bilan ularning ehtimollari orasidagi munosabatga tasodifiy miqdorning taqsimot qonuni deyiladi.

6. Diskret tasodifiy miqdorning matematik kutilmasi deb quyidagi tenglik bilan aniqlanadigan skalyar kattalikka aytiladi:

$$M(X) = x_1 p_1 + x_2 p_2 + \dots + x_n p_n$$

bu erda  $x_1, x_2, \dots, x_n$  – tasodifiy miqdorning mumkin bo'lgan qiymatlari,  $p_1, p_2, \dots, p_n$  – mos ehtimolliklar.

$$D(X) = M(x^2) - [M(x)]^2$$

ifodaga dispersiya deyiladi.

$$\sigma(X) = \sqrt{D(X)}$$

ifodaga o'rta kvadratik chetlashish deyiladi.

10.  $X$  tasodifiy miqdorning o'z matematik kutilmasidan chetlanishi absolyut qiymat bo'yicha  $\varepsilon$  musbat sondan kichik bo'lish ehtimoli  $1 - \frac{D(X)}{\varepsilon^2}$  dan kichik emas, ya'ni

$$P(|X - M(X)| < \varepsilon) \geq 1 - \frac{D(X)}{\varepsilon^2}.$$

Bu Chebishev tengsizligi deyiladi.

## 10-§. MATEMATIK STATISTIKA ELEMENTLARI

Statistika tabiatda va jamiyatda bo'ladigan ommaviy hodisalarni o'rganadi. Matematik statistikaning vazifasi statistik ma'lumotlarni to'plash, ularni tahlil qilish va shu asosda xulosalar chiqarishdan iborat.

Biror bir to'plamdan tasodifiy ravishda tanlab olingan ob'ektlar to'plamiga tanlanma deyiladi.

Tanlanma ajratiladigan ob'ektlar to'plami bosh to'plam deyiladi. Tanlanmaning hajmi deb, shu tanlanmadagi ob'ektlar soniga aytiladi.

Olingan ob'ekt kuzatish o'tkazilgandan keyin bosh to'plamga qaytarilsa takror tanlanma, qaytarilmasa notakror tanlanma deyiladi.

Biror  $X$  bosh to'plamdan  $x_1, x_2, \dots, x_n$  - tanlanma olingan bo'lsin. Agar  $x_1, x_2, \dots, x_n$  larni  $x_1^* \leq x_2^* \leq \dots \leq x_n^*$  kabi o'sish tartibida joylashtirsak,  $x_1^*, x_2^*, \dots, x_n^*$  variatsion qator hosil bo'ladi. Tanlanmaning elementlari variantalar deyiladi. Variantalarning har biri bir necha bor takrorlanishi mumkin:

$x_1^*$  varianta  $n_1$  marta,  $x_2^*$  varianta  $n_2$  marta, ...,  $x_k^*$  varianta  $n_k$  marta takrorlansin va  $n = n_1 + n_2 + \dots + n_k$  bo'lsin,  $n_1, n_2, \dots, n_k$  sonlar chastotalar deyiladi.

Har bir chastotaning tanlanma hajmi  $n$  ga nisbati shu variantaning nisbiy chastotasi deyiladi:

$$w_i = \frac{n_i}{n}, \quad i = \overline{1, k}.$$

X:  $x_1, x_2, \dots, x_k$ ;

W:  $w_1, w_2, \dots, w_k$ ;

jadval X tasodifiy miqdorning statistik yoki empirik taqsimoti deyiladi.

Variantalarning  $x$  sonidan kichik bo'lgan qiymatlarining nisbiy chastotasi

$$F_n(x) = \frac{m(x)}{n}$$

empirik taqsimot funksiya deyiladi. Chastotalar poligoni deb,  $(x_1, n_1)$ ;  $(x_2, n_2)$ ; ...;  $(x_k, n_k)$  nuqtalarni tutashtiruvchi siniq chiziqqa aytiladi. Nisbiy chastotalar poligoni deb esa,  $(x_1, w_1)$ ;  $(x_2, w_2)$ ; ...;  $(x_k, w_k)$  nuqtalarni tutashtiruvchi siniq chiziqqa aytiladi. Chastotalar gistogrammasi deb, asoslari  $h$ -uzunlikdagi intervallar, balandliklari esa,  $n_i$  -dan iborat bo'lgan to'g'ri to'rtburchaklardan iborat pog'onasimon shaklga aytiladi, bu erda  $h$ -bosh to'planning kuzatiladigan qiymatlarini o'z ichiga olgan interval uzunligi,  $n_i$  - intervalga tushgan variantalar soni. Matematik statistika o'rganadigan masalalardan biri - taqsimotning turli sonli xarakteristikalarini nuqtaviy baholashdan iborat. Nuqtaviy baho deb, bitta son bilan aniqlanadigan statistik bahoga aytiladi.

Tanlanmaning o'rta arifmetik qiymati:

$$\bar{X} = \frac{\sum_{i=1}^n x_i}{n}$$

bo'ladi, tanlanma dispersiyasi deb,

$$\sigma^2 = \frac{\sum_{i=1}^n n_i (x_i - \bar{x})^2}{\sum_{i=1}^n n_i}$$

ifodaga aytiladi. Bundan tashqari intervalli baholar ham qaraladi. Intervalli baho deb baholanayotgan parametрни qoplaydigan intervalning uchlari bo'lgan ikki son bilan aniqlanadigan bahoga aytiladi.

Statistik gipoteza deb, noma'lum taqsimotning ko'rinishi yoki ma'lum taqsimotlarning parametrlari haqidagi gipotezaga aytiladi. Gipotezalarni tekshirishda birinchi tur xatolik shundan iboratki, bunda, to'g'ri gipoteza rad qilinadi. Ikkinchi tur xatolik shundan iboratki, bunda, noto'g'ri gipoteza qabul qilinadi.

Statistik kriteriy (yoki oddiygina kriteriy) deb, nolinch gipotezani tekshirish uchun xizmat qiladigan tasodifiy miqdorga aytiladi. Bosh to'planning normal taqsimlanganligi haqidagi gipotezani tekshirishda quyidagi Pirson kriteriyasi ishlatiladi:

$$\chi^2 = \sum \frac{(n_i - n'_i)^2}{n'_i}$$

Pirson kriteriyasi yordamida empirik chastotalar  $n_i$  va nazariy chastotalar  $n'_i$  - lar taqqoslanadilar.

Agar  $X$  tasodifiy miqdorning har bir qiymatiga biror qonun asosida  $Y$  tasodifiy miqdorning taqsimoti yoki sonli xarakteristikasi mos kelsa, u holda  $X$  va  $Y$  orasidagi munosabat statistik yoki korrelyatsion munosabat deyiladi. Bu munosabatni jadval ko'rinishda ifodalash mumkin.

Bog'liqlik miqdori bo'lgan korrelyatsion koeffitsientini

$$r_{xy} = \frac{\sum x_i \cdot y_i - n \cdot \bar{x} \cdot \bar{y}}{n \cdot \sigma_x \sigma_y}$$

formula yordamida topish mumkin.

## II BOB. YOZMA ISH VARIANTLARINING NAMUNAVIY YEChIMLARI

### 1-§. BIRINChI YOZMA ISH

1. Biror bazisda  $\vec{a}(a_1, a_2, a_3)$ ,  $\vec{b}(b_1, b_2, b_3)$ ,  $\vec{c}(c_1, c_2, c_3)$  va  $\vec{d}(d_1, d_2, d_3)$  vektorlar berilgan.  $\vec{a}, \vec{b}, \vec{c}$  vektorlar bazis tashkil etishini ko'rsating va bu bazisda  $\vec{d}$  vektorning koordinatalarini toping.

**Berilishi:**

$$\vec{a}(1; -2; 3), \vec{b}(4; 7; 2), \vec{c}(6; 4; 2), \vec{d}(14; 18; 6).$$

$\vec{a}$ ,  $\vec{b}$  va  $\vec{c}$  - lar bazis tashkil etishi uchun ular nokomplanar bo'lishlari kerak.

Agarda  $\vec{a} \cdot \vec{b} \cdot \vec{c} \neq 0$  bo'lsa,  $\vec{a}$ ,  $\vec{b}$ ,  $\vec{c}$  vektorlar nokomplanar bo'ladi. Shuni tekshiramiz:

$$\vec{a} \cdot \vec{b} \cdot \vec{c} = \begin{vmatrix} 1 & -2 & 3 \\ 4 & 7 & 2 \\ 6 & 4 & 2 \end{vmatrix} = 14 - 24 + 48 - 126 + 16 - 8 = -80 \neq 0$$

Demak,  $\vec{a}$ ,  $\vec{b}$ ,  $\vec{c}$  - vektorlar bazis tashkil etadi.  $\vec{d}$  vektorning  $\vec{a}$ ,  $\vec{b}$ ,  $\vec{c}$  bazisdagi yoyilmasi  $\vec{d} = \lambda_1 \vec{a} + \lambda_2 \vec{b} + \lambda_3 \vec{c}$  ko'rinishda bo'ladi. Bunga  $\vec{a}$ ,  $\vec{b}$ ,  $\vec{c}$  va  $\vec{d}$  vektorlarning koordinatalarining qiymatlarini qo'yib quyidagini topamiz:

$$(14; 18; 6) = \lambda_1 (1; -2; 3) + \lambda_2 (4; 7; 2) + \lambda_3 (6; 4; 2);$$

$$(14; 18; 6) = (\lambda_1 + 4\lambda_2 + 6\lambda_3; -2\lambda_1 + 7\lambda_2 + 4\lambda_3; 3\lambda_1 + 2\lambda_2 + 2\lambda_3)$$

$$\begin{cases} \lambda_1 + 4\lambda_2 + 6\lambda_3 = 14 \\ -2\lambda_1 + 7\lambda_2 + 4\lambda_3 = 18 \\ 3\lambda_1 + 2\lambda_2 + 2\lambda_3 = 6 \end{cases} \Rightarrow \begin{cases} \lambda_1 + 4\lambda_2 + 6\lambda_3 = 14 \\ 15\lambda_2 + 16\lambda_3 = 46 \\ 10\lambda_2 + 16\lambda_3 = 36 \end{cases}$$

$$\Rightarrow \begin{cases} \lambda_1 + 4\lambda_2 + 6\lambda_3 = 14 \\ 15\lambda_2 + 16\lambda_3 = 46 \\ 5\lambda_2 = 10 \end{cases} \Rightarrow \begin{cases} \lambda_1 = 0 \\ \lambda_2 = 2; \\ \lambda_3 = 1 \end{cases}$$

Javob:  $\vec{d} = 2\vec{b} + \vec{c}$ ;

2.  $A_1A_2A_3A_4$  piramida uchlarning koordinatalari berilgan.

**Topping:**

- 1)  $A_1A_2$  qirrasining uzunligini.
- 2)  $A_1A_2$  va  $A_1A_4$  qirralari orasidagi burchagini.
- 3)  $A_1A_4$  qirradi bilan  $A_1A_2A_3$  yoqlar orasidagi burchagini.
- 4)  $A_1A_2A_3$  yoqlar yuzasini.
- 5) Piramida hajmini.
- 6)  $A_1A_2$  qirradi yotgan to'g'ri chiziq tenglamasini.
- 7)  $A_1A_2A_3$  tekisligining tenglamasini.
- 8)  $A_4$  uchidan  $A_1A_2A_3$  yoqqa tushirilgan balandlik tengamasini.

**Berilgan:**  $A_1(6,6,5), A_2(4,9,5), A_3(4,6,1), A_4(6,9,3)$

$$1) \overline{A_1A_2} = \{4-6 \quad 9-6 \quad 5-5\} = \{-2; 3; 0\};$$

$$|\overline{A_1A_2}| = \sqrt{(-2)^2 + 3^2 + 0^2} = \sqrt{13};$$

$$2) \overline{A_1A_2} = \{-2; 3; 0\};$$

$$\overline{A_1A_4} = \{6-6 \quad 9-6 \quad 3-5\} = \{0; 3; -2\};$$



$$\cos(\widehat{A_1 A_2; A_1 A_4}) = \frac{\overline{A_1 A_2} \cdot \overline{A_1 A_4}}{|\overline{A_1 A_2}| \cdot |\overline{A_1 A_4}|} = \frac{0 \cdot (-2) + 3 \cdot 3 + (-2) \cdot 0}{\sqrt{(-2)^2 + 3^2 + 0^2} \sqrt{0^2 + 3^2 + (-2)^2}} = \frac{9}{13};$$

$$\widehat{A_1 A_2; A_1 A_4} = \arccos \frac{9}{13} \approx 46^\circ 2';$$

3)  $A_1$  va  $A_4$  nuqtalardan o'tuvchi to'g'ri chiziq tenglamasi:

$$\frac{x - x_1}{x_4 - x_1} = \frac{y - y_1}{y_4 - y_1} = \frac{z - z_1}{z_4 - z_1}$$

Bundan  $\frac{x - 6}{6 - 6} = \frac{y - 6}{9 - 6} = \frac{z - 5}{3 - 5} \Rightarrow \frac{x - 6}{0} = \frac{y - 6}{3} = \frac{z - 5}{-2}$

kelib chiqadi.

Bu to'g'ri chiziqning yo'naltiruvchi vektori  $\vec{S} = \{0; 3; -2\}$ .

$A_1, A_2, A_3$  nuqtalardan o'tuvchi tekislik tenglamasi:

$$\begin{vmatrix} x - x_1 & y - y_1 & z - z_1 \\ x_2 - x_1 & y_2 - y_1 & z_2 - z_1 \\ x_3 - x_1 & y_3 - y_1 & z_3 - z_1 \end{vmatrix} = 0$$

Bundan,

$$\begin{vmatrix} x - 6 & y - 6 & z - 5 \\ 4 - 6 & 9 - 6 & 5 - 5 \\ 4 - 6 & 6 - 6 & 11 - 5 \end{vmatrix} = \begin{vmatrix} x - 6 & y - 6 & z - 5 \\ -2 & 3 & 0 \\ -2 & 0 & 6 \end{vmatrix} =$$

$$= 18(x - 6) + 6(z - 5) + 12(y - 6) =$$

$$= 18x + 12y + 6z - 210 = 0. \text{ yoki}$$

$6x + 4y + 2z - 70 = 0$  kelib chiqadi.

Bu tekislikning normali:  $\vec{n} = \{6; 4; 2\}$ .

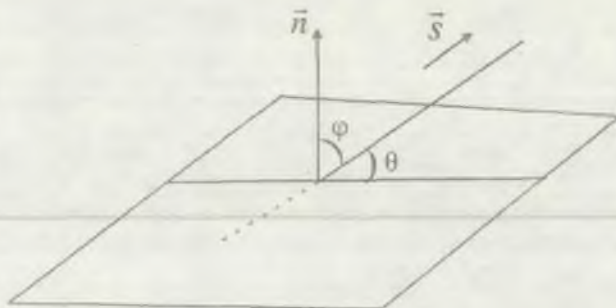

1-chizma

$\vec{n}$  va  $\vec{S}$  orasidagi burchak  $\varphi$  quyidagicha topiladi:

$$\cos \varphi = \frac{\vec{n} \cdot \vec{S}}{|\vec{n}| \cdot |\vec{S}|};$$

$A_1A_4$  va  $A_1A_2A_3$  lar orasidagi burchak  $\theta$  quyidagicha topiladi:

$$\theta = 90^\circ - \varphi \Rightarrow \varphi = 90^\circ - \theta;$$

$$\cos \varphi = \cos(90^\circ - \theta) = \sin \theta;$$

Demak, 
$$\sin \theta = \frac{\vec{n} \cdot \vec{S}}{|\vec{n}| \cdot |\vec{S}|};$$

$$\sin \theta = \frac{0 \cdot 6 + 3 \cdot 4 + (-2) \cdot 2}{\sqrt{0^2 + 3^2 + (-2)^2} \cdot \sqrt{6^2 + 4^2 + 2^2}} = \frac{8}{\sqrt{56} \cdot 13} = \frac{8}{\sqrt{578}};$$

$$\theta = \arcsin \frac{8}{\sqrt{578}};$$

4)  $A_1A_2A_3$  ning yuzini quyidagi formuladan topamiz:

$$S_{A_1A_2A_3} = \frac{1}{2} |\overline{A_1A_2} \times \overline{A_1A_3}|; \quad \overline{A_1A_2} = \{-2; 3; 0\};$$

$$\overline{A_1A_3} = \{4-6 \quad 6-6 \quad 11-5\} = \{-2; 0; 6\};$$

$$\overline{A_1A_2} \times \overline{A_1A_3} = \begin{vmatrix} \vec{i} & \vec{j} & \vec{k} \\ -2 & 3 & 0 \\ -2 & 0 & 6 \end{vmatrix} = \vec{i} \cdot \begin{vmatrix} 3 & 0 \\ 0 & 6 \end{vmatrix} - \vec{j} \cdot \begin{vmatrix} -2 & 0 \\ -2 & 6 \end{vmatrix} + \vec{k} \cdot \begin{vmatrix} -2 & 3 \\ -2 & 0 \end{vmatrix} =$$

$$= 18\vec{i} + 12\vec{j} + 6\vec{k};$$

$$S_{A_1A_2A_3} = \frac{1}{2} |18\vec{i} + 12\vec{j} + 6\vec{k}| = \frac{1}{2} \sqrt{18^2 + 12^2 + 6^2} \approx 11,22.$$

5) Piramidaning hajmini quyidagi formuladan topamiz.

$$V = \frac{1}{6} |\overline{A_1A_2} \cdot \overline{A_1A_3} \cdot \overline{A_1A_4}| = \frac{1}{6} \begin{vmatrix} -2 & 3 & 0 \\ -2 & 0 & 6 \\ 0 & 3 & -2 \end{vmatrix} = \frac{1}{6} |36 - 12| = \frac{24}{6} = 4.$$

6)  $A_1, A_2$  nuqtalardan o'tuvchi to'g'ri chiziq tenglamasi:

$$\frac{x - x_1}{x_2 - x_1} = \frac{y - y_1}{y_2 - y_1} = \frac{z - z_1}{z_2 - z_1}$$

yoki

$$\frac{x - 6}{4 - 6} = \frac{y - 6}{9 - 6} = \frac{z - 5}{5 - 5} \Rightarrow \frac{x - 6}{-2} = \frac{y - 6}{3} = \frac{z - 5}{0};$$

7)  $A_1A_2A_3$  - tekislik tenglamasi 3-bo'limda topildi:

$$6x + 4y + 2z - 70 = 0.$$

8)  $A_4$  uchidan  $A_1A_2A_3$  yoqqa tushirilgan balandlik tenglamasini

tuʻziling.  $A_4(6,9,3)$

$A_1A_2A_3$  - ning tenglamasi:  $6x + 4y + 2z - 70 = 0$ .

$\vec{n} = \{6, 4, 2\}$  - tekislikning normali.

$A_4$  - nuqtadan oʻtib yoʻnaltiruvchisi  $\vec{S} = \{m; n; l\}$  - boʻlgan toʻgʻri chiziqning tenglamasi.

$$\frac{x-6}{m} = \frac{y-9}{n} = \frac{z-3}{l};$$

Toʻgʻri chiziq bilan tekislikning perpendikulyarligidan  $\vec{n} \parallel \vec{S}$  ligi kelib chiqadi va  $m, n$  va  $l$  lar 6, 4, 2 larga proporsional boʻladi. Shuning uchun izlangan balandlik tenglamasi:

$$\frac{x-6}{6} = \frac{y-9}{4} = \frac{z-3}{2} \text{ boʻladi.}$$

3. Berilgan chizikli tenglamalar sistemasining birgalikdaligini koʻrsating va uni eching.

**Berilishi:**

$$\begin{cases} x_1 + x_2 - x_3 = 1 \\ 8x_1 + 3x_2 - 6x_3 = 2 \\ 4x_1 + x_2 - 3x_3 = 3 \end{cases}$$

Sistema birgalikda boʻlishi uchun asosiy determinant  $\Delta \neq 0$  boʻlishi kerak.

$$\Delta = \begin{vmatrix} 1 & 1 & -1 \\ 8 & 3 & -6 \\ 4 & 1 & -3 \end{vmatrix} = -9 - 24 - 8 + 12 + 24 + 6 = 1 \neq 0.$$

Demak, sistema birgalikda va yagona yechimga ega.

**Kramer usuli:**

Yechimlar quyidagi formulalar orqali topiladi:

$$x_1 = \frac{\Delta x_1}{\Delta}; x_2 = \frac{\Delta x_2}{\Delta}; x_3 = \frac{\Delta x_3}{\Delta};$$

$$\Delta x_1 = \begin{vmatrix} 1 & 1 & -1 \\ 2 & 3 & -6 \\ 3 & 1 & -3 \end{vmatrix} = -9 - 18 - 2 + 9 + 6 + 6 = -8;$$

$$\Delta x_2 = \begin{vmatrix} 1 & 1 & -1 \\ 8 & 2 & -6 \\ 4 & 3 & -3 \end{vmatrix} = -6 - 24 - 24 + 8 + 18 + 24 = -4;$$

$$\Delta x_3 = \begin{vmatrix} 1 & 1 & 1 \\ 8 & 3 & 2 \\ 4 & 1 & 3 \end{vmatrix} = 9 + 8 + 8 - 12 - 2 - 24 = 25 - 38 = -13;$$

$$x_1 = \frac{\Delta x_1}{\Delta} = \frac{-8}{1} = -8; \quad x_2 = \frac{\Delta x_2}{\Delta} = \frac{-4}{1} = -4; \quad x_3 = \frac{\Delta x_3}{\Delta} = \frac{-13}{1} = -13;$$

Javob:  $x_1 = -8$ ,  $x_2 = -4$ ,  $x_3 = -13$ .

Gauss usuli:

$$\begin{cases} x_1 + x_2 - x_3 = 1 \\ 8x_1 + 3x_2 - 6x_3 = 2 \\ 4x_1 + x_2 - 3x_3 = 3 \end{cases} \xrightarrow{(1)} \begin{cases} x_1 + x_2 - x_3 = 1 & (2) \\ 5x_2 - 2x_3 = 6 \\ 3x_2 - x_3 = 1 \end{cases}$$

$$\Rightarrow \begin{cases} x_1 + x_2 - x_3 = 1 & (3) \\ 5x_2 - 2x_3 = 6 \\ x_2 = -4 \end{cases} \Rightarrow \begin{cases} x_1 + x_2 - x_3 = 1 & (4) \\ 5 \cdot (-4) - 2 \cdot x_3 = 6 \\ x_2 = -4 \end{cases} \Rightarrow \begin{cases} x_1 = -8 \\ x_3 = -13 \\ x_2 = -4 \end{cases}$$

(1): Ikkinchi qator o'rniga, shu qatordan, birinchi qatorni 8 ga ko'paytirib ayirilgan natijani yozamiz.

(2): Uchinchi qator o'rniga, shu qatorni 3 ga ko'paytirib ikkinchi qatorni ayirilganini yozamiz. Natijada  $x_2 = -4$  qiymat hosil bo'ladi.

(3): Topilgan  $x_2 = -4$  qiymatni ikkinchi qatorga qo'yib  $x_3 = -13$  qiymatni topamiz.

(4): Topilgan  $x_2 = -4$  va  $x_3 = -13$  qiymatlarni birinchi qatorga qo'yib  $x_1 = -8$  qiymatni topamiz.

**Javob:**  $x_1 = -8, x_2 = -4, x_3 = -13$ .

4. Berilgan matritsaning xos son va xos vektorlarini toping:

$$\begin{pmatrix} 1 & 1 & 3 \\ 1 & 5 & 1 \\ 3 & 1 & 1 \end{pmatrix}$$

Xarakteristik tenglamasini tuzamiz:

$$\begin{vmatrix} 1-\lambda & 1 & 3 \\ 1 & 5-\lambda & 1 \\ 3 & 1 & 1-\lambda \end{vmatrix} = 0 \quad \text{yoki} \quad (\lambda+2) \cdot (-\lambda^2 + 9\lambda - 18) = 0.$$

Bundan  $\lambda_1 = -2, \lambda_2 = 3, \lambda_3 = 6$  xos sonlarni hosil qilamiz.

Endi,  $\lambda_1 = -2$  xos songa mos keluvchi xos vektorni topamiz:

Buning uchun quyidagi tenglamalar sistemasini tuzamiz va echamiz:

$$\begin{cases} [1 - (-2)] \cdot x_1 + x_2 + 3x_3 = 0 \\ x_1 + [5 - (-2)] \cdot x_2 + x_3 = 0 \\ 3x_1 + x_2 + [1 - (-2)] \cdot x_3 = 0 \end{cases}$$

yoki

$$\begin{cases} 3x_1 + x_2 + 3x_3 = 0 \\ x_1 + 7x_2 + x_3 = 0 \\ 3x_1 + x_2 + 3x_3 = 0 \end{cases}$$

Bu sistemada birinchi va uchinchi tenglamalar bir xil bo'lgani uchun, bittasini tashlab yozamiz:

$$\begin{cases} 3x_1 + x_2 + 3x_3 = 0 \\ x_1 + 7x_2 + x_3 = 0 \end{cases} \Rightarrow \begin{cases} 3(x_1 + x_3) = -x_2 \\ x_1 + x_3 = -7x_2 \end{cases}$$

Bundan biz quyidagini hosil qilamiz:

$$\begin{cases} x_1 + x_3 = -\frac{x_2}{3} \\ x_1 + x_3 = -7x_2 \end{cases}$$

Chap tomonlar tengligidan, o'ng tomonlar ham teng bo'lishi kerak. Bu esa, faqat  $x_2 = 0$  bo'lganda to'g'ri bo'ladi. Bundan esa  $x_1 = -x_3$  ekanligi kelib chiqadi. Bu erda,  $x_3$  ni erkli o'zgaruvchi deb olamiz.  $x_3 = 1$  desak  $x_1 = -1$ ,  $x_2 = 0$ . ya'ni  $\vec{v}_1(-1;0;1)$  xos vektorni olamiz.  $\lambda_2 = 3$  va  $\lambda_3 = 6$  xos sonlar uchun ham shu usulda xos vektorlarni topamiz:  $\vec{v}_2(1;-1;1)$ ,  $\vec{v}_3(1;2;1)$ .

5. Quyidagi tenglama qanday sirtni ifodalaydi?:

$$x^2 + y^2 = r^2.$$

Berilgan tenglama faqat  $x$  va  $y$  o'zgaruvchilarni o'z ichiga olgan va shuning uchun bu tenglama fazoda yasovchisi OZ o'qiga parallel bo'lgan, yo'naltiruvchisi OXY tekisligidagi  $x^2 + y^2 = r^2$  aylana bo'lgan silindrik sirtni ifodalaydi. Bu xulosani asoslaymiz:

OXY tekisligida berilgan tenglama markazi koordinata boshida bo'lgan va radiusi  $r$  ga teng aylananani aniqlaydi. Bu aylana silindrik sirtning yo'naltiruvchisi bo'lsin, yasovchisi esa OZ o'qiga parallel. Silindrdagi ixtiyoriy  $A(x,y,z)$  nuqtani olamiz va uni OXY tekisligiga proeksiyalaymiz. Koordinatalari  $x,y,0$  bo'lgan B proeksiya nuqta yo'naltiruvchi vazifasini bajaruvchi aylana ustiga tushadi va shuning uchun ham uning

koordinatalari  $x, y$  lar aylana tenglamasi  $x^2 + y^2 = r^2$  ni qanoatlantiradilar. Lekin silindrik sirtidagi  $A(x,y,z)$  nuqtaning absissasi ham, ordinatasi ham aylanaidagi  $B(x,y,0)$  nuqtaning absissasi va ordinatasi bilan aynan bir xil bo'lganlari uchun,  $x^2 + y^2 = r^2$  tenglama  $OZ$  o'zgaruvchini o'z ichiga olmaganini xisobga olgan holda, shuni aytish mumkinki, bu tenglamani silindrik sirtida yotuvchi ixtiyoriy  $A(x,y,z)$  nuqta koordinatalari ham qanoatlantiradi. Shunday qilib, berilgan  $x^2 + y^2 = r^2$  tenglama fazoda to'g'ri aylana silindrni aniqlaydi. Bu silindr yasovchisi  $OZ$  o'qiga parallel yo'naltiruvchisi esa  $OXY$  tekisligida yotuvchi  $x^2 + y^2 = r^2$  aylanaadir (2-chizma).

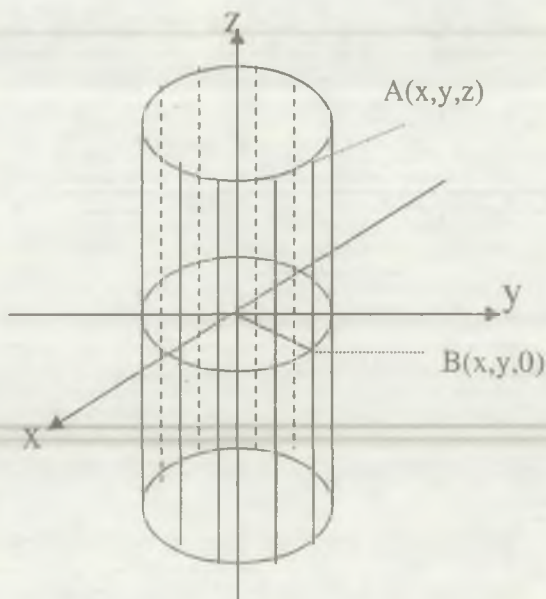

2-chizma

6. Lopital qoidasidan foydalanmay quyidagi funksiyalarning limitini hisoblang:



a)  $\lim_{x \rightarrow \infty} \frac{x - 2x^2 + 5x^4}{2 + 3x^2 + x^4} = \frac{\infty}{\infty}$  ko'rinishdagi aniqmaslik. Surat va mahrajini  $x^4$ -ga bo'lib limitga o'tamiz:

$$\lim_{x \rightarrow \infty} \frac{x - 2x^2 + 5x^4}{2 + 3x^2 + x^4} = \lim_{x \rightarrow \infty} \frac{\frac{x}{x^4} - \frac{2x^2}{x^4} + \frac{5x^4}{x^4}}{\frac{2}{x^4} + \frac{3x^2}{x^4} + \frac{x^4}{x^4}} = \lim_{x \rightarrow \infty} \frac{\frac{1}{x^3} - \frac{2}{x^2} + 5}{\frac{2}{x^4} + \frac{3}{x^2} + 1} =$$

$$= \frac{\lim_{x \rightarrow \infty} \frac{1}{x^3} - \lim_{x \rightarrow \infty} \frac{2}{x^2} + \lim_{x \rightarrow \infty} 5}{\lim_{x \rightarrow \infty} \frac{2}{x^4} + \lim_{x \rightarrow \infty} \frac{3}{x^2} + \lim_{x \rightarrow \infty} 1} = \frac{0 - 0 + 5}{0 + 0 + 1} = 5.$$

b)  $\lim_{x \rightarrow 0} \frac{\sqrt{1+3x^2}-1}{x^2+x^3} = \frac{0}{0}$  ko'rinishdagi aniqmaslik. Surat va mahrajini qo'shma ifoda  $(\sqrt{1+3x^2}+1)$  ga ko'paytiramiz:

$$\lim_{x \rightarrow 0} \frac{\sqrt{1+3x^2}-1}{x^2+x^3} = \lim_{x \rightarrow 0} \frac{(\sqrt{1+3x^2}-1)(\sqrt{1+3x^2}+1)}{(x^2+x^3)(\sqrt{1+3x^2}+1)} =$$

$$\lim_{x \rightarrow 0} \frac{1+3x^2-1}{x^2(1+x)(\sqrt{1+3x^2}+1)} = \lim_{x \rightarrow 0} \frac{3}{(1+x)(\sqrt{1+3x^2}+1)} = \frac{3}{2} = 1,5.$$

$$\lim_{x \rightarrow 0} \frac{1 - \cos 6x}{1 - \cos 2x} = \lim_{x \rightarrow 0} \frac{2 \sin^2 3x}{2 \sin^2 x} = \lim_{x \rightarrow 0} \frac{\sin^2 3x}{3x^2} \cdot \frac{x^2}{\sin^2 x} \cdot 9 =$$

v)

$$= 9 \lim_{x \rightarrow 0} \left( \frac{\sin 3x}{3x} \right)^2 \cdot \left( \frac{x}{\sin x} \right)^2 = 9.$$

Bu erda biz  $\lim_{kx \rightarrow 0} \frac{\sin kx}{kx} = \lim_{x \rightarrow 0} \frac{kx}{\sin kx} = 1$  birinchi ajoyib limitdan foydalandik.

$$\lim_{x \rightarrow \infty} (x-5) [\ln(x-3) - \ln x] = \lim_{x \rightarrow \infty} (x-5) \left[ \ln \frac{(x-3)}{x} \right] =$$

g)

$$\lim_{x \rightarrow \infty} \ln \left[ \left( 1 - \frac{3}{x} \right)^{x-5} \right] = \ln \lim_{x \rightarrow \infty} \left[ \left( 1 + \frac{-3}{x} \right)^{\frac{x-5}{-3}} \right] =$$

$$= \ln \left[ \lim_{x \rightarrow \infty} \left( 1 + \frac{-3}{x} \right)^{\frac{x-5}{-3}} \right]^{\lim_{x \rightarrow \infty} \frac{-3(x-5)}{-3}} = \ln e^{-3} = -3 \ln e = -3$$

Bu erda biz  $\lim_{x \rightarrow \infty} \left( 1 + \frac{1}{x} \right)^x = e$  ikkinchi ajoyib limitdan

foydalandik. Bundan tashqari lagorifm va ko'rsatkichli funksiyalarning uzluksizligidan limitni oldin lagorifm ichiga olib kirildi, so'ngra daraja ko'rsatkichiga olib chiqildi.

7.  $y = f(x)$  funksiya berilgan. Bu funksiyaning uzulish nuqtalarini toping (agar mavjud bo'lsa) va turini aniqlang. Chizmasini chizing.

$$\text{Berilishi: } f(x) = \begin{cases} -(x+1) & x \leq -1 \\ (x+2)^2 & -1 < x \leq 0 \\ x & x < 0 \end{cases}$$

$y = -(x+1)$ ,  $y = (x+2)^2$  va  $y = x$  funksiyalar  $\mathbb{R}$  o'plamda uzluksiz bo'lgani uchun  $y = f(x)$  funksiyani  $x_1 = -1$  va  $x_2 = 0$  nuqtalarda uzluksizlik shartiga tekshiramiz.

**Uzluksizlik sharti:**

$$\lim_{x \rightarrow x_0-0} f(x) = \lim_{x \rightarrow x_0+0} f(x) = f(x_0).$$

1)  $x = -1$  da

$$\lim_{x \rightarrow -1-0} -(x+1) = -(-1-0+1) = 0.$$

$$\lim_{x \rightarrow -1+0} (x+2)^2 = (-1+0+2)^2 = (1+0)^2 = 1.$$

$$f(-1) = -(-1+1) = 0.$$

Bu erda,

$$\lim_{x \rightarrow -1-0} f(x) \neq \lim_{x \rightarrow -1+0} f(x), \text{ va } \lim_{x \rightarrow -1-0} f(x) \neq \infty,$$

$\lim_{x \rightarrow -1+0} f(x) \neq \infty$ ,  $f(-1) \neq \infty$  bo'lgani uchun  $x = -1$  nuqta 1-

tur uzulish nuqtasidir. Funksiyaning sakrashi  $\Delta = |0 - 1| = 1$  bo'ladi.

$$1) \quad x=0 \text{ da } \lim_{x \rightarrow -0} (x+2)^2 = (0-0+2)^2 = (2-0)^2 = 4.$$

$$\lim_{x \rightarrow +0} x = 0.$$

$$f(0) = (0+2)^2 = 4$$

Bu erda  $\lim_{x \rightarrow -0} f(x) \neq \lim_{x \rightarrow +0} f(x)$  va  $\lim_{x \rightarrow -0} f(x) \neq \infty$ ,

$\lim_{x \rightarrow +0} f(x) \neq \infty$ ,  $f(0) \neq \infty$  bo'lgani uchun  $x = 0$  nuqta ham

1-tur uzulish nuqtasidir. Funksiyaning sakrashi  $\Delta = |0 - 4| = 4$  bo'ladi.

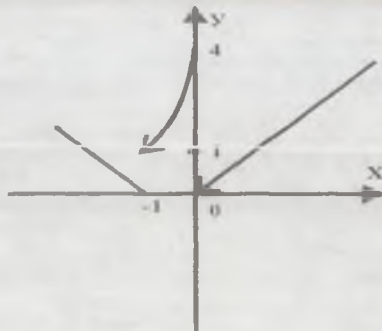

3-chizma

8. Berilgan funksiyalarning xosilasini taping.

a)

$$\begin{aligned}
 y &= \sqrt[3]{\frac{1+x^2}{1-x^2}}; \quad y' = \frac{1}{3} \left( \frac{1+x^2}{1-x^2} \right)^{\frac{1}{3}-1} \cdot \left( \frac{1+x^2}{1-x^2} \right)' = \\
 &= \frac{1}{3} \sqrt[3]{\left( \frac{1-x^2}{1+x^2} \right)^2} \cdot \frac{2x \cdot (1-x^2) + 2x \cdot (1+x^2)}{(1-x^2)^2} = \frac{1}{3} \frac{(1-x^2)^{\frac{2}{3}}}{(1+x^2)^{\frac{2}{3}}} \cdot \frac{4x}{(1-x^2)^2} = \\
 &= \frac{4}{3} \frac{x}{(1+x^2)^{\frac{2}{3}} (1-x^2)^{\frac{2}{3}}} = \frac{4}{3} \frac{x}{(1+x^2)^{\frac{2}{3}} (1-x^2)^{\frac{4}{3}}} = \\
 &= \frac{4x}{3\sqrt[3]{(1+x^2)^2 (1-x^2)} \sqrt{1-x^2}};
 \end{aligned}$$

$$b) \quad y = \frac{1}{2} \operatorname{tg}^2 x + \ln \cos x;$$

$$\begin{aligned}
 y' &= \frac{1}{2} 2 \operatorname{tg} x \cdot \frac{1}{\cos^2 x} + \frac{1}{\cos x} \cdot (-\sin x) = \operatorname{tg} x \left[ \frac{1}{\cos^2 x} - 1 \right] = \operatorname{tg} x \cdot \frac{1 - \cos^2 x}{\cos^2 x} = \\
 &= \operatorname{tg} x \cdot \frac{\sin^2 x}{\cos^2 x} = \operatorname{tg} x \cdot \operatorname{tg}^2 x = \operatorname{tg}^3 x.
 \end{aligned}$$

$$v) \quad y = \operatorname{arctg} \frac{x}{1 + \sqrt{1-x^2}};$$

$$\begin{aligned}
 y' &= \frac{1}{1 + \frac{x^2}{\left(1 + \sqrt{1-x^2}\right)^2}} \cdot \frac{x'(1 + \sqrt{1-x^2}) + x \cdot \frac{2x}{2\sqrt{1-x^2}}}{(1 + \sqrt{1-x^2})^2} = \\
 &= \frac{\left(1 + \sqrt{1-x^2}\right)^2}{1 + 2\sqrt{1-x^2} + 1 - x^2 + x^2} \cdot \frac{\sqrt{1-x^2} + 1 - x^2 + x^2}{\sqrt{1-x^2} (1 + \sqrt{1-x^2})^2} = \\
 &= \frac{1 + \sqrt{1-x^2}}{2(1 + \sqrt{1-x^2})} = \frac{1}{2};
 \end{aligned}$$

$$q) y = (x + x^2)^X; \quad (u^v)' = vu^{v-1}u' + u^v v' \ln u;$$

$$y' = ((x + x^2)^X)' = x(x + x^2)^{X-1}(1 + 2x) + (x + x^2)^X \ln(x + x^2) = \\ = (x + 2x^2)(x + x^2)^{X-1} + (x + x^2)^X \ln(x + x^2).$$

9. Berilgan funksiyalar uchun  $\frac{dy}{dx}$  va  $\frac{d^2y}{dx^2}$  lar topilsin:

a)

$$y = e^x \cos x;$$

$$\frac{dy}{dx} = (e^x \cos x)' = e^x \cos x - e^x \sin x = e^x (\cos x - \sin x).$$

$$\frac{d^2y}{dx^2} = \left( \frac{dy}{dx} \right)' = [e^x (\cos x - \sin x)]' =$$

$$= e^x (\cos x - \sin x) + e^x (-\sin x - \cos x) =$$

$$= e^x [\cos x - \sin x - \sin x - \cos x] = -2e^x \sin x.$$

b)

$$\begin{cases} x = 3t - t^3 \\ y = 3t^2 \end{cases} \Rightarrow \begin{cases} x'_t = 3 - 3t^2 \\ y'_t = 6t \end{cases} \Rightarrow \frac{dy}{dx} = \frac{y'_t}{x'_t} = \frac{6t}{3 - 3t^2} = \frac{2t}{1 - t^2};$$

$$\frac{d^2y}{dx^2} = \frac{\left( \frac{dy}{dx} \right)'_t}{x'_t} = \frac{\left( \frac{2t}{1 - t^2} \right)'_t}{3 - 3t^2} = \frac{2(1 - t^2) - 2t(-2t)}{(1 - t^2)^2 3(1 - t^2)} =$$

$$= \frac{2 - 2t^2 + 4t^2}{(1 - t^2)^3 3} = \frac{2}{3} \cdot \frac{1 + t^2}{(1 - t^2)^3};$$

10. Lopital qoidasidan foydalanib quyidagi limitlarni hisoblang:

a)

$$\lim_{x \rightarrow 0} \frac{e^{\alpha \cdot x} - e^{\beta \cdot x}}{\sin(\alpha \cdot x) - \sin(\beta \cdot x)} = \frac{0}{0} = \lim_{x \rightarrow 0} \frac{\left( e^{\alpha \cdot x} - e^{\beta \cdot x} \right)'}{\left( \sin(\alpha \cdot x) - \sin(\beta \cdot x) \right)'} =$$

$$= \lim_{x \rightarrow 0} \frac{\alpha \cdot e^{\alpha \cdot x} - \beta \cdot e^{\beta \cdot x}}{\alpha \cos(\alpha \cdot x) - \beta \cos(\beta \cdot x)} = \frac{\alpha \cdot e^0 - \beta \cdot e^0}{\alpha \cdot 1 - \beta \cdot 1} = 1.$$

b)

$$\lim_{x \rightarrow 1} \left( \frac{2x-1}{x} \right)^{\frac{1}{\sqrt[3]{x}-1}} = 1^\infty = \lim_{x \rightarrow 1} \frac{1}{\sqrt[3]{x}-1} \cdot \ln \left( \frac{2x-1}{x} \right) = \lim_{x \rightarrow 1} \frac{\ln \left( \frac{2x-1}{x} \right)}{\sqrt[3]{x}-1} =$$

$$= \frac{0}{0} = e \quad \lim_{x \rightarrow 1} \frac{\ln \left( \frac{2x-1}{x} \right)}{\left( \sqrt[3]{x}-1 \right)} = e \quad \lim_{x \rightarrow 1} \frac{x \cdot \frac{2x-2x+1}{x^2}}{\frac{1}{3} x^{-\frac{2}{3}}} = \frac{2}{3} \lim_{x \rightarrow 1} \frac{x^3}{(2x-1)x} = e^{\frac{2}{3}} = e^3,$$

11. Berilgan funksiyani  $x = x_0$  nuqta atrofida Lagranj ko'rinishi qoldiq hadli Teylor formulasi bo'yicha 4-darajali hadgacha yoying.

$$f(x) = x^4 - x + 1, \quad x_0 = -2.$$

$$f(x) = f(x_0) + \frac{f'(x_0)}{1!} (x - x_0) + \frac{f''(x_0)}{2!} (x - x_0)^2 +$$

$$+ \frac{f'''(x_0)}{3!} (x - x_0)^3 + \frac{f^{(4)}(x_0)}{4!} (x - x_0)^4 + R_4$$

$$f(-2) = 15;$$

$$f'(x) = 4x^3 - 1; \quad f'(-2) = -33;$$

$$f''(x) = 12x^2; \quad f''(-2) = 48;$$

$$f'''(x) = 24x; \quad f'''(-2) = -48;$$

$$f^{(4)}(x) = 24; \quad f^{(4)}(-2) = 24;$$

$$f^{(5)}(x) = 0; \quad f^{(5)}(-2) = 0;$$

Demak,

$$x^4 - x + 1 = 15 - 33(x+2) + 24(x+2)^2 - \frac{48}{6}(x+2)^3 + \frac{24}{4!}(x+2)^4 =$$

$$= 15 - 33(x+2) + 24(x+2)^2 - 8(x+2)^3 + (x+2)^4;$$

12. Berilgan funksiyani xosila yordamida tekshiring va tekshirish natijalariga ko'ra funksiyaning grafigini chizing:

$$f(x) = \frac{x^3}{x^2 - 1}$$

Bu funksiya  $x = \pm 1$  nuqtalardan tashqari barcha  $x$  ning qiymatlarida aniqlangan.

$f(-x) = \frac{(-x)^3}{(-x)^2 - 1} = \frac{-x^3}{x^2 - 1} = -\frac{x^3}{x^2 - 1} = -f(x)$  bo'lgani uchun bu funksiya toqdir. Toqligi uchun bu funksiyani  $x \geq 0$  qiymatlarda tekshirish etarlidir.  $x=0$  da  $f(0)=0$ ;  $x=1$  da mavjud emas va qolgan nuqtalarda uzluksiz, shuning uchun  $f(x)$  ning ishorasi quyidagicha aniqlanadi:

|      |             |                  |
|------|-------------|------------------|
| x    | $0 < x < 1$ | $1 < x < \infty$ |
| f(x) | -           | +                |

Demak,  $(0,1)$  oraliqda  $f(x)$  funksiyaning grafigi  $OX$  o'qidan pastda,  $(1,+\infty)$  oraliqda esa  $OX$  o'qidan yuqorida joylashgan. Funksiya grafigi  $x=1$  vertikal asimptotaga ega. Og'ma asimptotalarini  $y=kx+b$  ko'rinishda izlaymiz:

$$k = \lim_{x \rightarrow \infty} \frac{f(x)}{x} = \lim_{x \rightarrow \infty} \frac{\frac{x^3}{x^2-1}}{x} = \lim_{x \rightarrow \infty} \frac{x^2}{x^2-1} = 1$$

$$b = \lim_{x \rightarrow \infty} [f(x) - kx] = \lim_{x \rightarrow \infty} \left( \frac{x^3}{x^2-1} - x \right) = \lim_{x \rightarrow \infty} \frac{x}{x^2-1} = 0$$

$y=x$  og'ma asimptotasi.

Ekstremumlarini topamiz:

$$f'(x) = \frac{3x^2(x^2-1) - 2x \cdot x^3}{(x^2-1)^2} = \frac{x^2(x^2-3)}{(x^2-1)^2} = 0.$$

Bu tenglamaning musbat yechimlari  $x_1 = 0$ ,  $x_2 = \sqrt{3}$ .

$f'(x) > 0$  tengsizlikdan  $x^2 - 3 > 0$  tengsizlikni olamiz va uning musbat yechimlari  $x > \sqrt{3}$  ni hosil qilamiz. Bu oraliqda  $f'(x) > 0$  bo'lgani uchun funksiya o'suvchi.  $0 < x < \sqrt{3}$  oraliqda  $f'(x) < 0$  bo'lgani uchun funksiya bu oraliqda kamayuvchidir.

$x = \sqrt{3}$  da funksiya  $f(\sqrt{3}) = \frac{3\sqrt{3}}{2}$  minimumga ega.

$x=0$  nuqta, funksiya grafigi koordinata boshiga nisbatan simmetrik bo'lgani uchun, burilish nuqtasi bo'ladi.

Botiqlik va qabariqlikni tekshirish uchun ikkinchi hosilani topamiz:

$$f''(x) = \left( \frac{x^2(x^2-3)}{(x^2-1)^2} \right)' = \frac{2x(x^2+3)}{(x^2-1)^3}; \quad \text{Bundan } (1, +\infty)$$

oraliqda



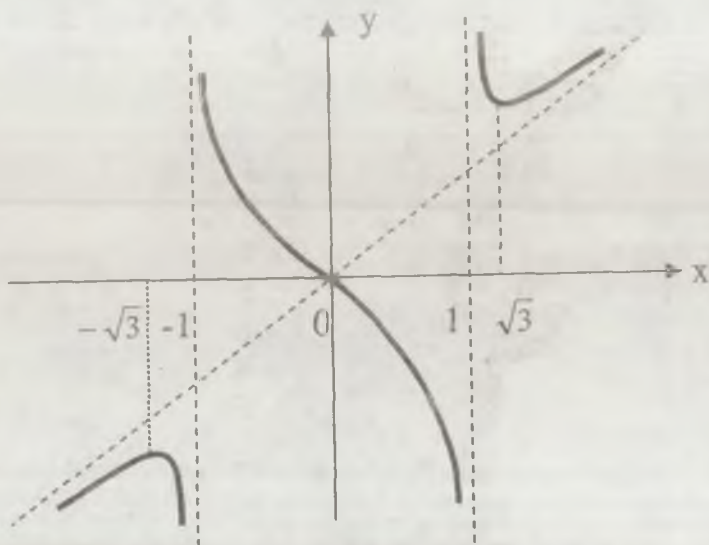

4-chizma

$f''(x) > 0$  bo'lgani uchun bu oraliqda funksiya grafigi botiq bo'ladi.  $(0,1)$  oraliqda  $f''(x) < 0$  bo'lgani uchun bu oraliqda funksiya grafigi qabariq bo'ladi.

Bu ma'lumotlarga asosan biz  $x \geq 0$  da funksiya grafigini yasay olamiz.  $x < 0$  larda esa funksiya grafigi koordinata boshiga nisbatan simmetrikligini nazarda tutib chizamiz (4-chizma).

## 2-§. IKKINCHI YOZMA ISH

1. Quyidagi aniqmas integrallarni hisoblang:

a)

$$\begin{aligned} \int \frac{\sin x dx}{\sqrt[3]{\cos^2 x}} &= \int \frac{-d \cos x}{\sqrt[3]{\cos^2 x}} = - \int (\cos x)^{-\frac{2}{3}} d \cos x = \\ &= \cos x = z \mid = - \int z^{-\frac{2}{3}} dz = - \frac{z^{-\frac{2}{3}+1}}{-\frac{2}{3}+1} + C = - \frac{z^{\frac{1}{3}}}{\frac{1}{3}} + C = \\ &= -3\sqrt[3]{z} + C = -3\sqrt[3]{\cos x} + C; \end{aligned}$$

b)

$$\int x \cdot \arcsin \frac{1}{x} dx = \left. \begin{array}{l} u = \arcsin \frac{1}{x} \quad du = \frac{-\frac{1}{x^2}}{\sqrt{1 - (\frac{1}{x})^2}} dx \\ dv = x dx \quad v = \frac{x^2}{2} \end{array} \right| =$$

$$= \frac{x^2}{2} \arcsin \frac{1}{x} - \int \frac{x^2}{2} \cdot \frac{-\frac{1}{x^2}}{\sqrt{x^2 - 1}} dx = \frac{x^2}{2} \arcsin \frac{1}{x} + \frac{1}{2} \int \frac{x dx}{\sqrt{x^2 - 1}} =$$

$$\frac{x^2}{2} \arcsin \frac{1}{x} + \frac{1}{2} \cdot \frac{1}{2} \cdot \int \frac{d(x^2 - 1)}{\sqrt{x^2 - 1}} = \frac{x^2}{2} \arcsin \frac{1}{x} + \frac{1}{4} \cdot \int (x^2 - 1)^{-\frac{1}{2}} d(x^2 - 1) =$$

$$= \frac{x^2}{2} \arcsin \frac{1}{x} + \frac{1}{4} \cdot \frac{(x^2 - 1)^{-\frac{1}{2} + 1}}{-\frac{1}{2} + 1} + C = \frac{x^2}{2} \arcsin \frac{1}{x} + \frac{1}{2} \cdot \sqrt{x^2 - 1} + C$$

v)

$$\int \frac{x+3}{x^3 + x^2 - 2x} dx = \int \frac{x+3}{x(x^2 + x - 2)} dx = \int \frac{x+3}{x(x-1)(x+2)} dx = I$$

$$\frac{x+3}{x(x-1)(x+2)} = \frac{A}{x} + \frac{B}{x-1} + \frac{C}{x+2} = \frac{Ax^2 + Ax - 2A + Bx^2 + 2Bx + Cx^2 - Cx}{x(x-1)(x+2)}$$

$$\begin{cases} A + B + C = 0 \\ A + 2B - C = 1, A = -\frac{2}{3}, \\ -2A = 3 \end{cases} \Rightarrow \begin{cases} B + C = \frac{3}{2} \\ 2B - C = \frac{5}{2} \end{cases} \Rightarrow 3B = \frac{8}{2} \Rightarrow B = \frac{8}{6};$$

$$C = \frac{3}{2} - \frac{8}{6} = \frac{1}{6};$$

$$\frac{x+3}{x(x-1)(x+2)} = -\frac{3}{2x} + \frac{8}{6(x-1)} + \frac{1}{6(x+2)};$$

$$I = \int \frac{x+3}{x(x-1)(x+2)} dx = -\frac{2}{3} \int \frac{dx}{x} + \frac{8}{6} \int \frac{d(x-1)}{x-1} + \frac{1}{6} \int \frac{d(x+2)}{x+2} =$$

$$= -\frac{3}{2} \ln x + \frac{4}{3} \ln(x-1) + \frac{1}{6} \ln(x+2) + C = \ln \left( \frac{(x-1) \cdot \sqrt[3]{x-1} \cdot \sqrt[6]{x+2}}{x\sqrt{x}} \right) + C.$$

g)

$$\int \frac{(\sqrt[4]{x}+1)dx}{(\sqrt{x}+4) \cdot \sqrt[4]{x^3}} = \left| \begin{array}{l} x=t^4 \quad t=\sqrt[4]{x} \\ dx=4t^3 dt \quad t^2=\sqrt{x} \end{array} \right| = \int \frac{(t+1) \cdot 4t^3 dt}{(t^2+4)t^3} =$$

$$= 4 \cdot \int \frac{t+1}{t^2+4} dt = 4 \left[ \int \frac{t}{t^2+4} dt + \int \frac{dt}{t^2+4} \right] = 4 \cdot \frac{1}{2} \cdot \int \frac{d(t^2+4)}{t^2+4} +$$

$$+ 4 \cdot \operatorname{arctg} \frac{t}{2} + C = 2 \ln |t^2+4| + 4 \operatorname{arctg} \frac{t}{2} + C = \ln |\sqrt{x}+4|^2 +$$

$$+ 4 \operatorname{arctg} \frac{\sqrt{x}}{2} + C.$$

2. Quyidagi xosmas integralni hisoblang yoki uzoqlashuvchiligini ko'rsating:

$$I = \int_{-3}^2 \frac{dx}{(x+3)^2} = \lim_{\varepsilon \rightarrow 0} \int_{-3+\varepsilon}^2 \frac{dx}{(x+3)^2} = \lim_{\varepsilon \rightarrow 0} \int_{-3+\varepsilon}^2 (x+3)^{-2} d(x+3) =$$

$$= \lim_{\varepsilon \rightarrow 0} \frac{(x+3)^{-2+1}}{-2+1} \Big|_{-3+\varepsilon}^2 = \lim_{\varepsilon \rightarrow 0} \left[ -\frac{1}{x+3} \Big|_{-3+\varepsilon}^2 \right] = -\lim_{\varepsilon \rightarrow 0} \left[ \frac{1}{5} - \frac{1}{\varepsilon} \right] =$$

$$= \lim_{\varepsilon \rightarrow 0} \frac{1}{\varepsilon} - \frac{1}{5} = \infty$$

Demak, berilgan integral uzoqlashuvchi.

3. Quyidagi egri chiziqlar bilan chegaralangan tekis shaklning yuzini hisoblang:

$$y = 4 - x^2 \quad \text{va} \quad y = x^2 - 2x; \quad S = S_1 + S_2 + S_3;$$

$$S_1 = \int_{-1}^0 [(4-x^2) - (x^2-2x)] dx = \int_{-1}^0 (4-2x^2+2x) dx =$$

$$= \left(4x - \frac{2x^3}{3} + x^2\right) \Big|_{-1}^0 = -(-4 + \frac{2}{3} + 1) = \frac{12-2-3}{3} = \frac{7}{3} = 2\frac{1}{3}$$

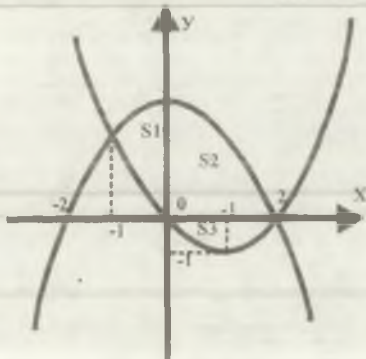

5-chizma

$$S_2 = \int_0^2 (4-x^2) dx = \int_0^2 4 dx - \int_0^2 x^2 dx = 4x \Big|_0^2 - \frac{x^3}{3} \Big|_0^2 = 8 - \frac{8}{3} = \frac{16}{3} = 5\frac{1}{3};$$

$$S_3 = -\int_0^2 (x^2-2x) dx = -\left(\frac{x^3}{3} - x^2\right) \Big|_0^2 = -\left(\frac{8}{3} - 4\right) = \frac{4}{3} = 1\frac{1}{3};$$

$$S = S_1 + S_2 + S_3 = 2\frac{1}{3} + 5\frac{1}{3} + 1\frac{1}{3} = 9;$$

4.  $z = f(x, y)$  - ikki o'zgaruvchili funksiya berilgan.

Quyidagi ayniyatni isbotlang:

$$F(x, y, z, \frac{\partial z}{\partial x}, \frac{\partial z}{\partial y}, \frac{\partial^2 z}{\partial x^2}, \frac{\partial^2 z}{\partial y^2}, \frac{\partial^2 z}{\partial x \partial y}) = 0.$$

$$z = \frac{x}{y}; \quad F = x \frac{\partial^2 z}{\partial x \partial y} - \frac{\partial z}{\partial y};$$

$$\frac{\partial z}{\partial x} = \frac{1}{y}; \quad \frac{\partial z}{\partial y} = -\frac{x}{y^2}; \quad \frac{\partial^2 z}{\partial x \partial y} = -\frac{1}{y^2};$$

$$F = x \cdot \left(-\frac{1}{y^2}\right) - \left(-\frac{x}{y^2}\right) = -\frac{x}{y^2} + \frac{x}{y^2} = 0.$$

5. Berilgan:  $z = \text{arctg}(x, y^2)$ ,  $A(2;3)$ ,  $\vec{a}(4;-3)$   
 a)  $z$  funksiyaning  $A$  nuqtada gradienti topilsin:

$$\text{grad}(z) \Big|_{A(2;3)} = \frac{\partial z}{\partial x} \Big|_{A(2;3)} \vec{i} + \frac{\partial z}{\partial y} \Big|_{A(2;3)} \vec{j};$$

$$\frac{\partial z}{\partial x} \Big|_{A(2;3)} = \frac{y^2}{1+x^2y^4} = \frac{3^2}{1+2^2 \cdot 3^4} = \frac{9}{325};$$

$$\frac{\partial z}{\partial y} \Big|_{A(2;3)} = \frac{2xy}{1+x^2y^4} = \frac{2^2 \cdot 3}{1+2^2 \cdot 3^4} = \frac{12}{325};$$

$$\text{grad}(z) \Big|_{A(2;3)} = \frac{9}{325} \vec{i} + \frac{12}{325} \vec{j};$$

b)  $z$ - funksiyaning  $A$  nuqtada,  $\vec{a}$  yo'nalish bo'ylab hosilasini quyidagi formuladan topamiz:

$$\frac{dz}{d\vec{a}} \Big|_A = \frac{dz}{dx} \Big|_A \cdot \cos\alpha + \frac{dz}{dy} \Big|_A \cdot \cos\beta \quad \text{bu erda } \cos\alpha = \frac{\vec{a}_x}{|\vec{a}|} = \frac{4}{5};$$

$$\cos\beta = \frac{\vec{a}_y}{|\vec{a}|} = -\frac{3}{5}; \quad \frac{dz}{d\vec{a}} \Big|_A = \frac{9}{325} \cdot \frac{4}{5} + \frac{12}{325} \cdot \left(-\frac{3}{5}\right) = 0$$

6. Berilgan differensial tenglamalarning umumiy yechimini toping:

a)

$$y' \cos x = (y+1) \sin x; \Rightarrow \frac{dy}{dx} \cos x = (y+1) \sin x; \Rightarrow$$

$$\Rightarrow \frac{dy}{y+1} = \frac{\sin x}{\cos x} dx \Rightarrow \int \frac{dy}{y+1} = \int \operatorname{tg} x dx; \Rightarrow$$

$$\Rightarrow \ln(y+1) = -\frac{1}{\cos^2 x} + \ln C; \Rightarrow y+1 = e^{-\frac{1}{\cos^2 x}} + C \Rightarrow$$

$$\Rightarrow y = e^{-\frac{1}{\cos^2 x}} + C_1;$$

b)

$$(1+y)y'' - 5(y')^2 = 0;$$

Belgilash kiritamiz:  $y' = p(y); \Rightarrow y'' = p' \cdot y' = p' \cdot p$   
 Tenglamaga qo'yamiz:

$$(1+y)p' \cdot p - 5p^2 = 0; \Rightarrow \frac{dp}{dy} \cdot (1+y) \cdot p = 5p^2; \Rightarrow \frac{p dp}{5p^2} =$$

$$= \frac{dy}{y+1}; \Rightarrow \int \frac{dp}{5p} = \int \frac{dy}{y+1}; \Rightarrow \frac{1}{5} \ln p = \ln C_1(y+1); \Rightarrow$$

$$\Rightarrow \sqrt[5]{p} = C_1(y+1); \Rightarrow p = C_1(y+1)^5; \Rightarrow y' = C_1(y+1)^5; \Rightarrow$$

$$\Rightarrow \frac{dy}{(y+1)^5} = C_1 dx; \Rightarrow \frac{(y+1)^{-4}}{-4} = C_1 x + C_2; \Rightarrow \frac{1}{(y+1)^4} =$$

$$= C_1 x + C_2; \Rightarrow (y+1)^4 = \frac{1}{C_1 x + C_2};$$

7. Berilgan tenglamaning to'la differensialli ekanligini ko'rsating va uning umumiy yechimini toping.

$$(3x^2 y + 2y + 3)dx + (x^3 + 2x + 3y^2)dy = 0;$$

Berilgan tenglamaning chap tomoni  $du = \frac{\partial u}{\partial x} dx + \frac{\partial u}{\partial y} dy$   
 ko'rinishga ega bo'lgani uchun, agar biz

$$\frac{\partial(3x^2y + 2y + 3)}{\partial y} = \frac{\partial(x^3 + 2x + 3y^2)}{\partial x};$$

ekanligini ko'rsatsak berilgan tenglamaning to'la differentsialligini ko'rsatgan bo'lamiz.

$$\frac{\partial(3x^2y + 2y + 3)}{\partial y} = \frac{\partial(3x^2y)}{\partial y} + 2\frac{\partial y}{\partial y} + \frac{\partial 3}{\partial y} = 3x^2 + 2;$$

$$\frac{\partial(x^3 + 2x + 3y^2)}{\partial x} = \frac{\partial(x^3)}{\partial x} + 2\frac{\partial x}{\partial x} + 3\frac{\partial y^2}{\partial x} = 3x^2 + 2;$$

Demak, tenglama to'la differentsialli va biz uning yechimini  $u(x, y) = C$  ko'rinishda izlaymiz:

$$\frac{\partial u}{\partial x} = 3x^2y + 2y + 3;$$

$$u(x, y) = \int(3x^2y + 2y + 3)dx + \varphi(y) = x^3y + 2xy + 3x + \varphi(y);$$

$$\frac{\partial u}{\partial y} = x^3 + 2x + \varphi'(y) = x^3 + 2x + 3y^2;$$

Bundan,

$$\varphi(y) = 3y^2; \Rightarrow \frac{\partial \varphi}{\partial y} = 3y^2 \Rightarrow d\varphi = 3y^2 dy; \Rightarrow \varphi(y) = y^3; \Rightarrow$$

$$\Rightarrow u(x, y) = x^3y + 2xy + 3x + y^3 = C.$$

8. Berilgan differensial tenglamaning umumiy yechimini toping:

$$x^2 y'' + xy' = 1;$$

Quyidagi almashtirishni bajaramiz:

$$y' = p(x), \Rightarrow y'' = p'(x) \Rightarrow$$

$$x^2 p'(x) + xp(x) = 1; \Rightarrow p'(x) = -\frac{1}{x} p(x) + \frac{1}{x};$$

Bu chiziqli tenglamadir.  $p = u(x) \cdot v(x)$  almashtirishni bajaramiz.

U holda,  $p'(x) = u'v + uv'$  va bularni chiziqli tenglamaga qo'yib quyidagini hosil qilamiz:

$$u'v + uv' = -\frac{1}{x} uv + \frac{1}{x}; \Rightarrow$$

$$(u'v + \frac{1}{x} u \cdot v) + (u'v - \frac{1}{x} uv) = 0; \Rightarrow \begin{cases} v \cdot (u' + \frac{1}{x} u) = 0 \\ u \cdot v' - \frac{1}{x} uv = 0 \end{cases}$$

$$u' + \frac{1}{x} u = 0; \Rightarrow \frac{du}{dx} = -\frac{1}{x} u \Rightarrow \frac{du}{u} = -\frac{dx}{x}; \Rightarrow \ln u = -\ln x \Rightarrow$$

$$\Rightarrow u = \frac{1}{x}; \Rightarrow \frac{1}{x} v' - \frac{1}{x} v = 0; \Rightarrow v' = 1 \Rightarrow v = x + C_1; \Rightarrow$$

$$\Rightarrow p = u \cdot v = \frac{1}{x}(x + C_1) = 1 + \frac{C_1}{x}; \Rightarrow y' = p(x) = 1 + \frac{C_1}{x} \Rightarrow$$

$$\Rightarrow dy = (1 + \frac{C_1}{x}) dx \Rightarrow y = x + C_1 \ln x + C_2.$$

9. Berilgan  $y'' - 5y' + 6y = (12x - 7)e^{-x}$  tenglamaning  $y(0) = 0, y'(0) = 0$  boshlang'ich shartlarni qanoatlantiruvchi hususiy yechimini toping.

$y'' - 5y' + 6y = 0$  mos keluvchi bir jinsli tenglama. Berilgan bir jinsli bo'lmagan tenglamaning umumiy yechimini  $y = y_0 + \tilde{y}$  ko'rinishda izlaymiz. Bu erda  $y_0$  -mos bir jinsli tenglamaning umumiy yechimi.  $\tilde{y}$  esa berilgan bir jinsli bo'lmagan tenglamaning biror xususiy yechimi. Bir jinsli



tenglamaning karakteristik tenglamasi  $\lambda^2 - 5\lambda + 6 = 0$ ; Ildizlari  $\lambda_1 = 2$ ,  $\lambda_2 = 3$ ; Demak,  $y_1 = e^{2x}$ ,  $y_2 = e^{3x}$ ; Bundan bir jinsli tenglamaning umumiy yechimi  $y_0(x) = C_1 e^{2x} + C_2 e^{3x}$  ni xosil qilamiz. Xususiy yechim  $\tilde{y}$  ni quyidagi ko'rinishda izlaymiz:  $y = (Ax + B)e^{-x}$ ,

$$y' = Ae^{-x} + (Ax + B)(-e^{-x}) = Ae^{-x} - (Ax + B)e^{-x};$$

$$y'' = -Ae^{-x} - Ae^{-x} + (Ax + B)e^{-x};$$

Berilgan tenglamaga qo'yamiz:

$$\begin{aligned} -2Ae^{-x} + (Ax + B)e^{-x} - 5Ae^{-x} + 5(Ax + B)e^{-x} + (Ax + B)e^{-x} &= \\ = (12x - 7)e^{-x}; \end{aligned}$$

Bundan quyidagilar hosil bo'ladi:

$$\begin{cases} -7A + 7B = -7 \\ 7A = 12 \end{cases} \Rightarrow \begin{cases} -7 \cdot \frac{12}{7} + 7B = -7 \\ A = \frac{12}{7} \end{cases} \Rightarrow \begin{cases} A = \frac{12}{7} \\ 7B = -7 + 12 \end{cases} \Rightarrow$$

$$\begin{aligned} \Rightarrow \begin{matrix} A = \frac{12}{7} \\ B = \frac{5}{7} \end{matrix}; \Rightarrow \tilde{y} = \left(\frac{12}{7}x + \frac{5}{7}\right) \cdot e^{-x} \end{aligned}$$

$$y = y_0 + \tilde{y} = C_1 e^{2x} + C_2 e^{3x} + \left(\frac{12}{7}x + \frac{5}{7}\right)e^{-x}; \quad (1)$$

$$y' = 2C_1 e^{2x} + 3C_2 e^{3x} + \frac{12}{7}e^{-x} - \left(\frac{12}{7}x + \frac{5}{7}\right)e^{-x}; \quad (2)$$

$$(1) \Rightarrow 0 = C_1 + C_2 + \frac{5}{7} \Rightarrow C_1 + C_2 = -\frac{5}{7};$$

$$(2) \Rightarrow 0 = 2C_1 + 3C_2 + \frac{12}{7} - \frac{5}{7} \Rightarrow 2C_1 + 3C_2 = -1;$$

$$\begin{cases} C_1 + C_2 = -\frac{5}{7} \\ 2C_1 + 3C_2 = -1 \end{cases} \times 2 \Rightarrow \begin{cases} 2C_1 + 2C_2 = -\frac{10}{7} \\ 2C_1 + 3C_2 = -1 \end{cases} \Rightarrow C_2 = -1 + \frac{10}{7} = \frac{3}{7}$$

$$C_1 + \frac{3}{7} = -\frac{5}{7} \Rightarrow C_1 = -\frac{3}{7} - \frac{5}{7} = -\frac{8}{7}; \Rightarrow$$

$$\Rightarrow y = -\frac{8}{7} \cdot e^{2x} + \frac{3}{7} \cdot e^{3x} + \left(\frac{12}{7}x + \frac{5}{7}\right) \cdot e^{-x};$$

10. O'zgaras koeffitsientli chiziqli tenglamalar sistemasi berilgan. Xarakteristik tenglamalar usulida sistemaning umumiy yechimini toping.

$$\begin{cases} \frac{dx}{dt} = 3x - 2y \\ \frac{dy}{dt} = 2x + 8y \end{cases} \Rightarrow \begin{vmatrix} 3-\lambda & -2 \\ 2 & 8-\lambda \end{vmatrix} = 0; \Rightarrow (3-\lambda)(8-\lambda) + 4 = 0. \Rightarrow$$

$$\Rightarrow \lambda^2 - 11\lambda + 28 = 0.$$

$$\lambda_{1/2} = \frac{11 \pm \sqrt{121 - 4 \cdot 28}}{2} = \frac{11 \pm 3}{2}; \quad \lambda_1 = \frac{11}{2} + \frac{3}{2} = 7, \quad \lambda_2 = \frac{11}{2} - \frac{3}{2} = 4;$$

$$\begin{cases} (3-\lambda)z_1^\lambda - 2z_2^\lambda = 0 \\ 2z_1^\lambda + (8-\lambda)z_2^\lambda = 0 \end{cases};$$

$$\lambda = \lambda_1 = 7.$$

$$\begin{cases} -4\lambda z_1^\lambda - 2z_2^\lambda = 0 \\ 2z_1^\lambda + \lambda z_2^\lambda = 0 \end{cases} \Rightarrow z_1^\lambda = 1 \Rightarrow z_2^\lambda = -2.$$

Xos vektori:  $z^{\lambda_1} = \begin{pmatrix} z_1^{\lambda_1} \\ z_2^{\lambda_1} \end{pmatrix} = \begin{pmatrix} +1 \\ -2 \end{pmatrix};$

$$\lambda = \lambda_2 = 4$$

$$\begin{cases} -\lambda z_1^{\lambda_2} - 2z_2^{\lambda_2} = 0 \\ 2z_1^{\lambda_2} + z_2^{\lambda_2} = 0 \end{cases} \Rightarrow z_2^{\lambda_2} = 1 \Rightarrow z_1^{\lambda_2} = -2.$$

Xos vektori:  $z^{\lambda_2} = \begin{pmatrix} z_1^{\lambda_2} \\ z_2^{\lambda_2} \end{pmatrix} = \begin{pmatrix} 1 \\ -2 \end{pmatrix};$

$$\begin{pmatrix} x(t) \\ y(t) \end{pmatrix}^{\lambda_1} = \begin{pmatrix} 1 \\ -2 \end{pmatrix} e^{7t}; \quad \begin{pmatrix} x(t) \\ y(t) \end{pmatrix}^{\lambda_2} = \begin{pmatrix} -2 \\ 1 \end{pmatrix} e^{4t};$$

$$\begin{pmatrix} x(t) \\ y(t) \end{pmatrix} = C_1 \begin{pmatrix} 1 \\ -2 \end{pmatrix} e^{7t} + C_2 \begin{pmatrix} -2 \\ 1 \end{pmatrix} e^{4t};$$

### 3-§. UChINChI YOZMA ISH

1.  $\sum_{n=1}^{\infty} U_n$  sonli qatorni yaqinlashishga tekshiring.

Berilgan:

$$U_n = \frac{2n}{n^2 + 1}$$

Dalamber usulini qo'llaymiz:

$$U_{n+1} = \frac{2(n+1)}{(n+1)^2 + 1} = \frac{2n+2}{n^2 + 2n + 2};$$

$$l = \lim_{n \rightarrow \infty} \frac{u_{n+1}}{u_n} = \lim_{n \rightarrow \infty} \frac{2n+2}{\frac{n^2 + 2n + 2}{\frac{2n}{n^2 + 1}}} = \lim_{n \rightarrow \infty} \frac{(2n+2)(n^2 + 1)}{2n(n^2 + 2n + 2)} =$$

$$= \lim_{n \rightarrow \infty} \frac{(2n^3 + 2n + 2n^2 + 2) : n^3}{(2n^3 + 4n^2 + 4n) : n^3} = \lim_{n \rightarrow \infty} \frac{2 + \frac{2}{n^2} + \frac{2}{n} + \frac{2}{n^3}}{2 + \frac{4}{n} + \frac{4}{n^2}} = \frac{2}{2} = 1.$$

$l=1$  bo'lgan holda Dalamber usuli javob bermaydi.  
Integral usulini qo'llaymiz:

$$\int_1^A \frac{2x}{x^2 + 1} dx = \lim_{A \rightarrow \infty} \int_1^A \frac{d(x^2 + 1)}{x^2 + 1} = \lim_{A \rightarrow \infty} \ln(x^2 + 1) \Big|_1^A =$$
$$= \lim_{A \rightarrow \infty} [\ln(A^2 + 1) - \ln 2] = \ln(\infty) - \ln 2 = \infty$$

Demak, berilgan qator uzoqlashuvchi.

2. Berilgan ishoralari almashinuvchi sonli qatorni yaqinlashishga tekshiring:

Berilgan, 
$$\sum_{n=1}^{\infty} (-1)^n \frac{1}{\sqrt[3]{n^4} + \sqrt[4]{n^3}};$$

Bunda Leybnis belgisini qo'llaymiz:

$$U_1 = \frac{1}{1+1} = \frac{1}{2};$$

$$U_2 = \frac{1}{\sqrt[3]{2^4} + \sqrt[4]{2^3}} = \frac{1}{2\sqrt[3]{2} + \sqrt[4]{2^3}} < \frac{1}{2\sqrt[3]{1^4} + \sqrt[4]{1^3}} = \frac{1}{3} < U_1;$$

$$U_3 = \frac{1}{3\sqrt[3]{3} + \sqrt[4]{3^3}} < \frac{1}{2\sqrt[3]{2^4} + \sqrt[4]{2^3}} = U_2$$

.....

$$U_n = \frac{1}{n\sqrt[3]{n} + \sqrt[4]{n^3}} < \frac{1}{(n-1)\sqrt[3]{n-1} + \sqrt[4]{(n-1)^3}} = U_{n-1};$$

.....

Demak,

$$U_1 > U_2 > U_3 > U_4 > \dots > U_n > \dots$$

$$\text{va } \lim_{n \rightarrow \infty} U_n = \lim_{n \rightarrow \infty} \frac{1}{n\sqrt[3]{n} + \sqrt[4]{n^3}} = 0.$$

Demak, berilgan qator yaqinlashuvchi.

3.  $\sum_{n=1}^{\infty} a_n x^n$  darajali qatorning yaqinlashish sohasini

toping:

Berilgan:

$$a_n = \frac{(n!)^2}{(2n)!};$$

Dalamber belgisini qo'llaymiz:

$$\begin{aligned} \lim_{n \rightarrow \infty} \left| \frac{((n+1)!)^2 x^{n+1}}{(2n+2)!} \right| &= \lim_{n \rightarrow \infty} \left| \frac{((n+1)!)^2 x^{n+1} (2n)!}{(2n+2)!(n!)^2 x^n} \right| = \\ &= \lim_{n \rightarrow \infty} \left| \frac{(n+1)^2 x}{(2n+1)(2n+2)} \right| = \lim_{n \rightarrow \infty} \frac{(n+1)^2}{(2n+1)(2n+2)} |x| = \\ &= |x| \cdot \lim_{n \rightarrow \infty} \frac{n^2 + 2n + 1}{4n^2 + 6n + 2} = \frac{1}{4} \cdot |x| < 1 \end{aligned}$$

Bu erdan  $|x| < 4$  ya'ni  $-4 < x < 4$  kelib chiqadi.

Yaqinlashish sohasi:  $-4 < x < 4$ .

4. Differensial tenglamaning berilgan boshlang'ich shartlarni qanoatlantiruvchi yechimining Teylor qatoriga yoyilmasidagi dastlabki noldan farqli 4 hadini toping.

$$\text{Berilgan: } y' = \sin 2x + \cos y. \quad y\left(\frac{\pi}{2}\right) = \pi$$

$$y'\left(\frac{\pi}{2}\right) = \sin 2 \cdot \frac{\pi}{2} + \cos \pi = 0 - 1 = -1$$

$$y'' = 2 \cos 2x - y' \sin y;$$

$$y''\left(\frac{\pi}{2}\right) = 2 \cdot \cos 2 \cdot \frac{\pi}{2} + 1 \cdot \sin \pi = -2;$$

$$y''' = -4 \sin 2x - y'' \sin y - (y')^2 \cdot \cos y;$$

$$y'''\left(\frac{\pi}{2}\right) = -4 \sin 2 \cdot \frac{\pi}{2} - y''\left(\frac{\pi}{2}\right) \sin \pi - \left(y'\left(\frac{\pi}{2}\right)\right)^2 \cos \pi = 2 \cdot 0 + 1 = 1;$$

$$\begin{aligned}
 f(x) &= e^{-x} = \frac{a_0}{2} + \sum_{n=1}^{\infty} (a_n \cos nx + b_n \sin nx) = \\
 &= \frac{1}{\pi} \left( \frac{e^{2\pi} - 1}{e^{\pi}} \right) + \sum_{n=1}^{\infty} \left[ \frac{(-1)^n}{(n^2 + 1)\pi} \cdot \left( \frac{e^{2\pi} - 1}{e^{\pi}} \right) \cdot \cos nx + \right. \\
 &\quad \left. \frac{n \cdot (-1)^n}{(n^2 + 1)\pi} \cdot \left( \frac{e^{2\pi} - 1}{e^{\pi}} \right) \cdot \sin nx \right] = \frac{1}{\pi} \left( \frac{e^{2\pi} - 1}{e^{\pi}} \right) + \\
 &\quad \frac{1}{\pi} \left( \frac{e^{2\pi} - 1}{e^{\pi}} \right) \cdot \sum_{n=1}^{\infty} \left[ \frac{(-1)^n}{n^2 + 1} \cdot \cos nx + \frac{n \cdot (-1)^n}{n^2 + 1} \cdot \sin nx \right]
 \end{aligned}$$

6. Berilgan ikki karrali integralda integrallash tartibini o'zgartiring:

**Berilishi:**

$$\int_0^1 dx \int_{1-x^2}^1 f(x, y) dy + \int_1^e dx \int_{\ln x}^1 f(x, y) dy = I$$

$$x = 0, e; \quad y = 1; \quad y = 1 - x^2; \quad y = \ln x;$$

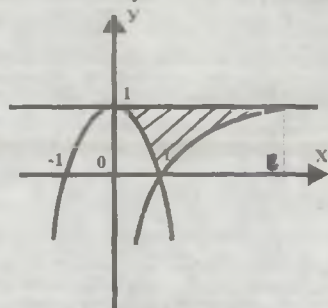

6-chizma

$$y = 1 - x^2 \Rightarrow x^2 = 1 - y \Rightarrow x = \pm \sqrt{1 - y}$$

$$y = \ln x \Rightarrow x = e^y$$

$$I = \int_0^1 dy \int_{\sqrt{1-y}}^{e^y} f(x, y) dx$$

7. Berilgan ikki o'lchamli integralni hisoblang:

Berilishi:

$$\iint_{(D)} (8xy + 9x^2y^2) dx dy ;$$

$$(D) : x = 1, y = \sqrt[3]{x}, y = -x^3 ;$$

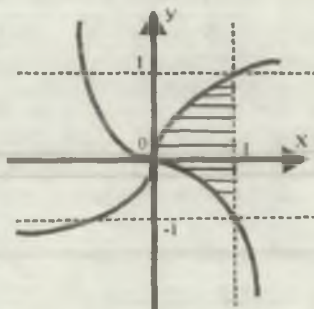

7-chizma

$$\iint_{(D)} (8xy + 9x^2y^2) dx dy =$$

$$\begin{aligned} &= \int_0^1 dx \int_{-x^3}^{\sqrt[3]{x}} (8xy + 9x^2y^2) dy = \int_0^1 \left[ 4xy^2 \Big|_{-x^3}^{\sqrt[3]{x}} + 3x^2y^3 \Big|_{-x^3}^{\sqrt[3]{x}} \right] dx = \\ &= \int_0^1 \left[ 4x^3\sqrt[3]{x^2} - 4xx^6 + 3x^2x + 3x^2x^9 \right] dx = \\ &= \int_0^1 \left[ 4x^{1+\frac{2}{3}} - 4x^7 + 3x^3 + 3x^{11} \right] dx = \frac{4x^{\frac{5}{3}+1}}{\frac{5}{3}+1} \Big|_0^1 - 4 \frac{x^8}{8} \Big|_0^1 + \\ &+ 3 \frac{x^4}{4} \Big|_0^1 + 3 \frac{x^{12}}{12} \Big|_0^1 = \frac{3}{2} - \frac{1}{2} + \frac{3}{4} + \frac{1}{4} = 2 \end{aligned}$$

8. Tenglamasi Dekart koordinatlarida berilgan egri chiziq bilan chegaralangan yassi figuraning yuzini ikki o'lchamli



integral yordamida qutb koordinatalar sistemasiga o'tib hisoblang ( $a > 0$ ).

$$\text{Berilishi: } (x^2 + y^2)^2 = a^2(2x^2 + 3y^2)$$

Bu tenglama - lemniskata deb ataluvchi egri chiziq tenglamasidir. Qutb kordinatalariga o'tamiz:

$$x = \rho \cos \theta, y = \rho \sin \theta.$$

$$(\rho^2 \cos^2 \theta + \rho^2 \sin^2 \theta)^2 = a^2(2\rho^2 \cos^2 \theta + 3\rho^2 \sin^2 \theta)$$

$$\rho^4 = a^2 \rho^2 (2 \cos^2 \theta + 3 \sin^2 \theta)$$

$$\rho^2 = a^2 (2 + \sin^2 \theta)$$

$$\rho = a \cdot \sqrt{2 + \sin^2 \theta}.$$

Demak, qutb koordinatalar sistemasida figuraning chegaralari quyidagi tenglamalar bilan aniqlanadi:

$$\rho = \Phi_1(\theta) = 0, \quad \rho = \Phi_2(\theta) = a\sqrt{2 + \sin^2 \theta};$$

$\theta$  burchakning 0 dan  $\frac{\pi}{2}$  gacha o'zgarishi yassi figuraning

$\frac{1}{4}$  yuzasiga mos keladi.

$$\frac{1}{4} S = \int_0^{\frac{\pi}{2}} d\theta \int_{\Phi_1}^{\Phi_2} \rho d\rho = \int_0^{\frac{\pi}{2}} d\theta \int_0^{a\sqrt{2 + \sin^2 \theta}} \rho d\rho =$$

$$\int_0^{\frac{\pi}{2}} \frac{\rho^2}{2} \Big|_0^{a\sqrt{2 + \sin^2 \theta}} d\theta = \int_0^{\frac{\pi}{2}} \frac{1}{2} a^2 (2 + \sin^2 \theta) d\theta = \frac{2a^2}{2} \theta \Big|_0^{\frac{\pi}{2}} + \frac{1}{2} a^2 \int_0^{\frac{\pi}{2}} \frac{1 - \cos 2\theta}{2} d\theta$$

$$= \frac{\pi a^2}{4} + \frac{1}{2} a^2 \left[ \frac{1}{2} \theta \Big|_0^{\frac{\pi}{2}} - \frac{1}{4} \sin 2\theta \Big|_0^{\frac{\pi}{2}} \right] = \frac{\pi a^2}{4} + \frac{\pi}{8} a^2 = \frac{3\pi a^2}{8}$$

Bundan esa,  $S = \frac{3\pi a^2}{2}$  ekanligi kelib chiqadi.

1. Berilgan sirtlar bilan chegaralangan jismning hajmini uch o'lchamli integral yordamida hisoblang.

**Berilishi:**

$$z = 0, \quad z = 4 - x - y, \quad x = 2, \quad y = 3,$$

$$x = 0, \quad y = 0;$$

Jismning hajmi quyidagi formula yordamida topiladi:

$$V = \int_a^b dx \int_{y_1(x)}^{y_2(x)} \int_{f_1(x,y)}^{f_2(x,y)} dz$$

Berilgan sirtlar bilan chegaralangan jismning ko'rinishi quyidagichadir:

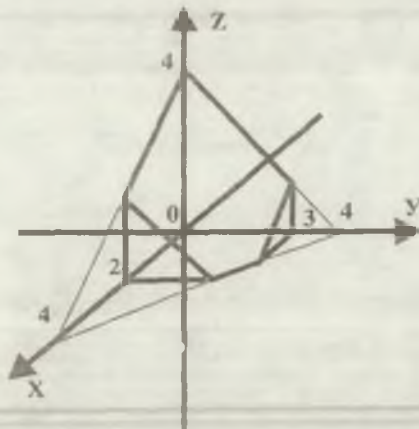

8-chizma

$$f_1(x, y) = 0, \quad f_2(x, y) = 4 - x - y;$$

$$y_1(x) = 3 \quad x = 0 \quad \text{dan}; \quad x = 1 \quad \text{gacha}$$

$$y_1(x) = 4 - x \quad x = 1 \quad \text{dan}; \quad x = 2 \quad \text{gacha}$$

$$a = 0; \quad b = 2;$$

Demak,

$$\begin{aligned}
 V &= \int_0^1 dx \int_0^{4-x} dy \int_0^{4-x-y} dz + \int_0^1 dx \int_0^{4-x} dy \int_0^{4-x-y} dz = \int_0^1 dx \int_0^{4-x} [4-x-y] dy \\
 &= \int_0^1 dx \int_0^{4-x} [4-x-y] dy = \int_0^1 \left( 4y - xy - \frac{y^2}{2} \right) \Big|_0^{4-x} dx + \int_0^1 \left( 4y - xy - \frac{y^2}{2} \right) \Big|_0^{4-x} dx = \\
 &= \int_0^1 \left( 12 - 3x - \frac{9}{2} \right) dx + \int_0^1 \left( 16 - 4x - 4x + x^2 - \frac{16 - 8x + x^2}{2} \right) dx = \\
 &= \int_0^1 (7,5 - 3x) dx + \int_0^1 \left( 8 - 4x + \frac{x^2}{2} \right) dx = (7,5x - 1,5x^2) \Big|_0^1 + \\
 &= \left( 8x - 2x^2 + \frac{1}{6}x^3 \right) \Big|_0^1 = 9 \frac{1}{6};
 \end{aligned}$$

2.  $L: 2x + y = 2$  to'g'ri chiziqning  $A(1;0)$  nuqtasidan  $B(0,2)$  nuqtasigacha bo'lgan kesma bo'ylab berilgan

$\int_L (xy - 1) dx + x^2 y dy$  egri chizikli integralni hisoblang.

$$2x + y = 2 \Rightarrow y = 2 - 2x$$

$$\int_A^B (xy - 1) dx + x^2 y dy = \int_1^0 (x(2-2x) - 1) dx + \int_1^0 x^2 (2-2x) d(2-2x) =$$

$$= \int_1^0 (2x - 2x^2 - 1) dx + \int_1^0 (2x^2 - 2x^3) (-2) dx = \int_1^0 [2x - 2x^2 - 1 + (2x^2 - 2x^3) (-2)] dx =$$

$$= \int_1^0 (2x - 2x^2 - 1 - 4x^2 + 4x^3) dx = \int_1^0 (4x^3 - 6x^2 + 2x - 1) dx = (x^4 - 2x^3 + x^2 - x) \Big|_1^0 =$$

$$-1 + 2 - 1 + 1 = 1$$

#### 4-§. TO'RTINCHI YOZMA ISH

1. Kompleks ifodaning qiymatini hisoblang:

$$W = (-1 - i)^{1+i}$$

$$W = (-1 - i)^{1+i} =$$

$$= e^{(1+i)Ln(-1-i)} = e^{(1+i)\left(\ln\sqrt{2} + i\cdot\left(-\frac{3\pi}{4} + 2\pi k\right)\right)} =$$

$$= e^{(1+i)\left(\frac{1}{2}\ln 2 + i\cdot\left(-\frac{3\pi}{4} + 2\pi k\right)\right)} =$$

$$= e^{\frac{1}{2}\ln 2 + i\left(-\frac{3\pi}{4} + 2\pi k\right) + \frac{i}{2}\ln 2 + i^2\left(-\frac{3\pi}{4} + 2\pi k\right)} =$$

$$= e^{\frac{1}{2}\ln 2 - \left(-\frac{3\pi}{4} + 2\pi k\right) + i\cdot\left(-\frac{3\pi}{4} + 2\pi k + \frac{1}{2}\ln 2\right)} =$$

$$= e^{\frac{1}{2}\ln 2 - \frac{3\pi}{4} + 2\pi k} \cdot \left(\cos\left(\frac{\ln 2}{2} - \frac{3\pi}{4}\right) + i \cdot \sin\left(\frac{\ln 2}{2} - \frac{3\pi}{4}\right)\right);$$

2. Berilgan kompleks o'zgaruvchili  $W = f(z)$ ,  $z = x + iy$  funksiyani  $W = U(x, y) + iV(x, y)$  ko'rinishda yozing va uning analitikligini tekshiring. Agar  $W = f(z)$  funksiya analitik bo'lsa uning berilgan  $z_0$  nuqtada hosilasini toping:

$$W = e^{iz^2}, z_0 = \frac{\sqrt{\pi}}{2}i$$

$$W = e^{i \cdot (x + iy)^2} = e^{i \cdot (x^2 + 2ixy - y^2)} = e^{-2xy + (x^2 - y^2)} \cdot i = e^{-2xy} e^{(x^2 - y^2)} \cdot i = e^{-2xy} \left( \cos(x^2 - y^2) + i \sin(x^2 - y^2) \right).$$

Koshi-Riman shartini tekshiramiz:

$$\frac{\partial U}{\partial x} = \frac{\partial V}{\partial y}; \quad \frac{\partial U}{\partial y} = -\frac{\partial V}{\partial x};$$

$$\begin{aligned} \frac{\partial U}{\partial x} &= \frac{\partial}{\partial x} \left( e^{-2xy} \cos(x^2 - y^2) \right) = -2e^{-2xy} \cos(x^2 - y^2) + \\ &+ e^{-2xy} (-\sin(x^2 - y^2) 2x) = -2e^{-2xy} \left( y \cos(x^2 - y^2) + x \sin(x^2 - y^2) \right); \end{aligned}$$

$$\begin{aligned} \frac{\partial V}{\partial y} &= \frac{\partial}{\partial y} \left( e^{-2xy} \sin(x^2 - y^2) \right) = -2e^{-2xy} \sin(x^2 - y^2) + \\ &+ e^{-2xy} \cos(x^2 - y^2) (-2y) = -2e^{-2xy} \left( x \sin(x^2 - y^2) + y \cos(x^2 - y^2) \right); \end{aligned}$$

$$\text{Demak, } \frac{\partial U}{\partial x} = \frac{\partial V}{\partial y};$$

$$\begin{aligned} \frac{\partial U}{\partial y} &= \frac{\partial}{\partial y} \left( e^{-2xy} \cos(x^2 - y^2) \right) = -2xe^{-2xy} \cos(x^2 - y^2) + \\ &+ e^{-2xy} (-\sin(x^2 - y^2) (-2y)) = 2e^{-2xy} \left( y \sin(x^2 - y^2) + x \cos(x^2 - y^2) \right); \end{aligned}$$

$$\begin{aligned} \frac{\partial V}{\partial x} &= \frac{\partial}{\partial x} \left( e^{-2xy} \sin(x^2 - y^2) \right) = -2ye^{-2xy} \sin(x^2 - y^2) + \\ &+ e^{-2xy} (x \cos(x^2 - y^2) (2x)) = 2e^{-2xy} \left( x \cos(x^2 - y^2) - y \sin(x^2 - y^2) \right); \end{aligned}$$

Demak,

$$\frac{\partial U}{\partial y} = -\frac{\partial V}{\partial x};$$

Bundan kelib chiqadiki berilgan funksiya analitikdir.

$$\begin{aligned} \frac{\partial W}{\partial z} &= \frac{\partial U}{\partial x} + i \frac{\partial v}{\partial x} = -2e^{-2xy} \left( y \cos(x^2 - y^2) + x \sin(x^2 - y^2) \right) + \\ &+ i \left( 2e^{-2xy} \left( \cos(x^2 - y^2) - y \sin(x^2 - y^2) \right) \right) = \\ &- 2ye^{-2xy} \left[ \cos(x^2 - y^2) + i \sin(x^2 - y^2) \right] + \\ &+ 2xe^{-2xy} \left[ i \cos(x^2 - y^2) - \sin(x^2 - y^2) \right] = \\ &= 2xie^{-2xy} \left[ \cos(x^2 - y^2) + i \sin(x^2 - y^2) \right] - \\ &- 2ye^{-2xy} \left[ \cos(x^2 - y^2) + i \sin(x^2 - y^2) \right] = 2xie^{iz^2} - 2ye^{iz^2} \\ &= 2e^{iz^2} (xi - y) = 2ie^{iz^2} (x + iy) = 2ize^{iz^2}. \end{aligned}$$

$$\begin{aligned} \frac{\partial W}{\partial z} \Big|_{z_0} &= \frac{\sqrt{\pi}}{2} \cdot i = 2i \frac{\sqrt{\pi}}{2} ie^{i \cdot \left( \frac{\sqrt{\pi}}{2} \cdot i \right)^2} = -\pi e^{-i \cdot \frac{\pi}{4}} = \\ &= -\pi \left( \cos \frac{\pi}{4} - i \sin \left( \frac{\pi}{4} \right) \right) = -\pi \left( \frac{\sqrt{2}}{2} - \frac{\sqrt{2}}{2} i \right) = -\frac{\sqrt{2}}{2} \pi + \frac{\sqrt{2}}{2} \pi \cdot i \end{aligned}$$

3. Berilgan  $f(z)$  funksiyani  $z_0$  nuqta atrofida Loran qatoriga yoying va uning yaqinlashish sohasini toping:

$$f(z) = \frac{7z - 19}{z^2 - 6z + 5}; \quad z_0 = 1.$$

$$f(z) = \frac{7z - 19}{z^2 - 6z + 5} = \frac{7z - 19}{(z - 5)(z - 1)} = \frac{A}{z - 5} + \frac{B}{z - 1} =$$

$$= \frac{A(z - 1) + B(z - 5)}{(z - 1)(z - 5)}; \Rightarrow A(z - 1) + B(z - 5) = 7z - 19.$$

$$z = 1 \Rightarrow -4B = -12 \Rightarrow B = 3$$

$$z = 5 \Rightarrow 4A = 16 \Rightarrow A = 4$$

$$\text{Demak, } f(z) = \frac{4}{z - 5} + \frac{3}{z - 1};$$

Ma'lumki,

$$\frac{1}{1 - z} = \sum_{n=0}^{\infty} z^n, \quad |z| < 1 \text{ da.}$$

Bundan

$$\frac{4}{z - 5} = \frac{4}{-4 + (z - 1)} = -\frac{4}{4 - (z - 1)} = \frac{-4}{4 \left(1 - \frac{z - 1}{4}\right)} =$$

$$= -\frac{1}{1 - \frac{z - 1}{4}} = -\sum_{n=0}^{\infty} \left(\frac{z - 1}{4}\right)^n = -\sum_{n=0}^{\infty} \frac{(z - 1)^n}{4^n};$$

Demak,

$$f(z) = -\sum_{n=0}^{\infty} \frac{(z - 1)^n}{4^n} + \frac{3}{z - 1}; \quad 0 < |z - 1| < 1$$

doirada yaqinlashuvchidir.

4. Berilgan integralni hisoblang:

$$I = \int_{|z|=7} \frac{e^z}{z^3 - 5z^2} dz;$$

Integrallash sohasining grafigini tuzamiz:

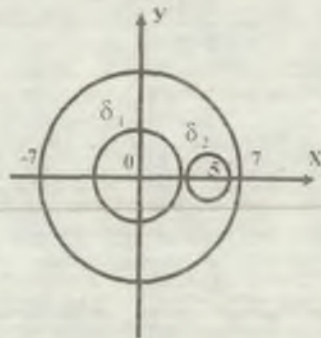

9-chizma

$$\begin{aligned}
 \text{Demak, } \int_{|z|=7} \frac{e^z}{z^3 - 5z^2} dz &= \int_{\delta_1} \frac{e^z}{z^3 - 5z^2} dz + \int_{\delta_2} \frac{e^z}{z^3 - 5z^2} dz = \\
 &= \int_{\delta_1} \frac{e^z}{z^2} dz + \int_{\delta_2} \frac{e^z}{z-5} dz = \frac{2\pi i}{1!} \left( \frac{e^z}{z-5} \right) \Big|_{z=0} + 2\pi i \left( \frac{e^z}{z^2} \right) \Big|_{z=5} = \\
 &= 2\pi i \left( \frac{e^z(z-5) - e^z}{|z-5|^2} \right) \Big|_{z=0} + 2\pi i \left( \frac{e^5}{25} \right) = 2\pi i \left( \frac{-6}{25} \right) + 2\pi i \left( \frac{e^5}{25} \right) = \\
 &= 2\pi i \left( \frac{e^5 - 6}{25} \right) = \frac{2\pi i}{25} (e^5 - 6)
 \end{aligned}$$

5. Agar A hodisining har bir sinovda ro'y berish ehtimoli 0,25 ga teng bo'lsa, bu hodisining 243 ta sinovda rosa 70 marta ro'y berish ehtimolini toping.

Masala shartiga ko'ra  $n=243$ ,  $k=70$ ,  $p=0,25$ ,  $q=0,75$ ;  $n=243$  etarlicha katta son bo'lgani uchun Laplasning ushbu lokal teoremasidan foydalanamiz:

$$P_n(k) = \frac{1}{\sqrt{npq}} \varphi(x),$$



bu erda,

$$x = \frac{k - np}{\sqrt{npq}}$$

x ning qiymatini topamiz:

$$x = \frac{k - np}{\sqrt{npq}} = \frac{70 - 243 \cdot 0,25}{\sqrt{243 \cdot 0,25 \cdot 0,75}} = \frac{9,25}{6,75} = 1,37$$

Jadvaldan (Gmurman, 1-ilova)

$\varphi(1,37) = 0,1561$  ni topamiz.

Izlanayotgan ehtimol

$$P_{243}(70) = \frac{1}{6,75} \cdot 0,1561 = 0,0231$$

6. X diskret tasodifiy miqdor faqat ikkita  $x_1$  va  $x_2$  qiymatga ega bo'lib  $x_1 > x_2$ . X-ning  $x_1$  qiymatni qabul qilish ehtimoli 0,6 ga teng. Matematik kutilish va dispersiya ma'lum:  $M(x) = 1,4$ .  $D(x) = 0,24$ . X ning taqsimot qonunini toping.

Diskret tasodifiy miqdorning barcha mumkin bo'lgan qiymatlarning ehtimollari yig'indisi birga teng, Shuning uchun X ning  $x_2$  qiymatni qabul qilish ehtimoli  $1 - 0,6 = 0,4$  ga teng.

Demak,

$$\begin{array}{l} X: \quad x_1 \quad x_2 \\ P: \quad 0,6 \quad 0,4 \end{array} \quad (1)$$

$x_1$  va  $x_2$  larni topish uchun bu sonlarni o'zaro bog'laydigan ikkita tenglamani tuzish lozim. Shu maqsada biz ma'lum matematik kutilish va dispersiyani  $x_1$  va  $x_2$  orqali ifodalaymiz.

$M(X)$  ni topamiz.

$$M(X) = 0,6 x_1 + 0,4 x_2$$

Shartga ko'ra  $M(X) = 1,4$  demak,  $0,6 x_1 + 0,4 x_2 = 1,4$ .

Ikkinchi tenglamani hosil qilish uchun bizga ma'lum dispersiyani  $x_1$  va  $x_2$  orqali ifodalaymiz. Buning uchun  $X^2$  ning taqsimot qonunini yozamiz:

$$\begin{array}{l} X^2: \quad x_1^2 \quad x_2^2 \\ P: \quad 0,6 \quad 0,4 \end{array}$$

$$M(x^2) = 0,6x_1^2 + 0,4x_2^2;$$

$$Dx = M(x^2) - (M(x))^2 = 0,6x_1^2 + 0,4x_2^2 - (1,4)^2;$$

$$D(x) = 0,24 \text{ bo'lgani uchun: } 0,6x_1^2 + 0,4x_2^2 = 2,2;$$

$$\begin{cases} 0,6x_1^2 + 0,4x_2^2 = 1,4; \\ 0,6x_1^2 + 0,4x_2^2 = 2,2; \end{cases} \Rightarrow \begin{cases} x_1 = 1 \\ x_2 = 2 \end{cases} \cup \begin{cases} x_1 = 1,8 \\ x_2 = 0,8 \end{cases}$$

Shartga ko'ra  $x_1 > x_2$ , shuning uchun masalani faqat birinchi yechim

$$x_1 = 1, \tag{2}$$

$$x_2 = 2$$

qanoatlantiradi. (2) ni (1) ga qo'yib, izlanayotgan taqsimot qonunini hosil qilamiz:

|   |     |     |
|---|-----|-----|
| X | 1   | 2   |
| P | 0,6 | 0,4 |

7.  $\xi$  - tasodifiy miqdorning zichlik funksiyasi berilgan.

$$P_{\xi}(x) = \begin{cases} h, & -2 \leq x \leq 3 \text{ da} \\ 0, & x < -2, x > 3 \text{ da} \end{cases}$$

$h, M_{\xi}, D_{\xi}, P(1 < \xi < 5)$  va  $F_{\xi}(x)$  larni toping:

$$1) \int_{-\infty}^{\infty} P_{\xi}(x) dx = \int_{-\infty}^{-2} P_{\xi}(x) dx + \int_{-2}^3 P_{\xi}(x) dx + \int_3^{\infty} P_{\xi}(x) dx = 5h = 1 \Rightarrow h = 0,2.$$

$$2) M_{\xi} = \int_{-\infty}^{\infty} x P_{\xi}(x) dx = \int_{-2}^3 x P_{\xi}(x) dx = 0,2 \int_{-2}^3 x dx = 0,1x^2 \Big|_{-2}^3 = 0,5$$

$$3) D_{\xi} = \int_{-\infty}^{\infty} (x-0,5)^2 \cdot P_{\xi}(x) dx = \int_{-2}^3 (x-0,5)^2 \cdot 0,2 dx \approx 2,1$$

$$4) P(1 < \xi < 5) = \int_1^5 P_{\xi}(x) dx = \int_1^3 P_{\xi}(x) dx + \int_3^5 P_{\xi}(x) dx = \int_1^3 0,2 dx = 0,4.$$

5) Agar  $x < -2$  bo'lsa,

$$F_{\xi}(x) = \int_{-\infty}^x P_{\xi}(x) dx = 0$$

Agar  $x > 3$  bo'lsa,

$$F_{\xi}(x) = \int_{-\infty}^x P_{\xi}(x) dx = \int_{-\infty}^{-2} P_{\xi}(x) dx + \int_{-2}^3 P_{\xi}(x) dx + \int_3^x P_{\xi}(x) dx = \int_{-2}^3 0,2 dx = 1$$

chunki  $x < -2$  da va  $x > 3$  da  $P_{\xi}(x) = 0$ .

Agar  $-2 \leq x \leq 3$  bo'lsa,

$$F_{\xi}(x) = \int_{-\infty}^x P_{\xi}(x) dx = \int_{-\infty}^{-2} P_{\xi}(x) dx + \int_{-2}^x P_{\xi}(x) dx = \int_{-2}^x 0,2 dx = 0,2 \cdot (x+2)$$

Shunday qilib,

$$F_{\xi}(x) = \begin{cases} 0, & x < -2 \\ 0,2(x+2) & -2 \leq x \leq 3 \\ 1 & x \geq 3 \end{cases}$$

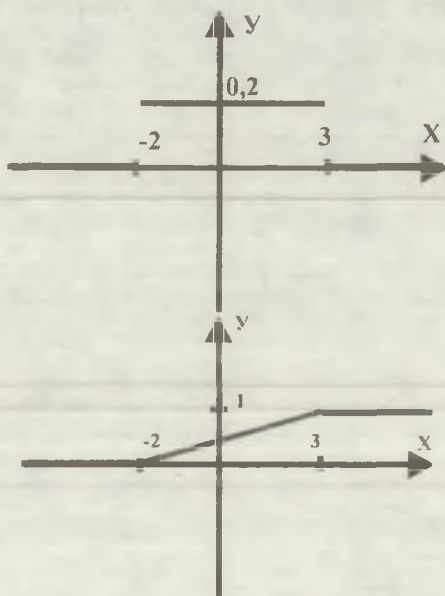

10-chizma

8. Normal taqsimlangan  $X$ - tasodifiy miqdorning matematik kutilishi va dispersiyasi mos ravishda 10 va 2 ga teng. Tajriba natijasida  $X$ - ning (12:14) intervalda yotadigan qiymat qabul qilish ehtimolini toping.

$X$ -ning  $(\alpha, \beta)$  intervalga tegishli qiymat qabul qilish ehtimoli

$$P(\alpha < x < \beta) = \Phi\left(\frac{\beta - a}{\tau}\right) - \Phi\left(\frac{\alpha - a}{\tau}\right); \text{ bu erda,}$$

$$\Phi(x) = \frac{1}{\sqrt{2\pi}} \int_0^x e^{-x^2/2} dx - \text{Laplas funksiyasidir.}$$

Bunga  $\alpha = 12; \beta = 14; a = 10; \tau = 2$  -larni qo'yib

$$\frac{\beta - a}{\tau} = \frac{14 - 10}{2} = 2; \frac{\alpha - a}{\tau} = \frac{12 - 10}{2} = 1$$

va  $P(\alpha < x < \beta) = \Phi(2) - \Phi(1)$ ; -larni hosil qilamiz.

Jadvaldan foydalanib:

$$\Phi(2) = 0,4772, \Phi(1) = 0,3413 \text{ ni topamiz.}$$

Izlanayotgan ehtimol:

$$P(\alpha < x < \beta) = 0,1359 \text{ ga teng.}$$

9. Bosh to'planning normal taqsimlangan  $X$ - belgisining noma'lum  $a$ - matematik kutilishini 0,95 ishonchlik bilan baholash uchun ishonchlik intervalini toping. Bosh o'rtacha kvadratik chetlanish  $\sigma = 5$ , tanlanma o'rtacha qiymat  $\bar{x} = 14$  va tanlanma hajmi  $n = 25$  berilgan.

Ushbu ishonchlik intervalini topish talab etilmoqda:

$$\bar{x} - t \frac{\tau}{\sqrt{n}} < a < \bar{x} + t \frac{\tau}{\sqrt{n}} \quad (1)$$

Bu erda,  $t$ -dan boshqa barcha kattaliklar ma'lum,  $t$  ni tolamiz:

$2\Phi(t) = 0,95$  munosabatdan  $\Phi(t) = 0,475$  ni hosil qilamiz, Jadvaldan  $t=1,96$  ni topamiz,  $t=1,96$ ,  $\tau = 5$ ,  $\bar{x} = 14$ ,  $n = 25$  -larni (1) ga qo'yib uzil-kesil ushbu izlanayotgan ishonchlik intervalini hosil qilamiz:  $12,04 < a < 15,96$ .

### III BOB. YOZMA ISH TOPSHIRIQLARI

#### 1-§. BIRINCHI YOZMA ISH TOPSHIRIQLARI

##### Vektorlar algebra si va analitik geometriya

1.(1-20) Biror bazisda  $\vec{a}(a_1, a_2, a_3)$ ,  $\vec{b}(b_1, b_2, b_3)$ ,  $\vec{c}(c_1, c_2, c_3)$  va  $\vec{d}(d_1, d_2, d_3)$  vektorlar berilgan.  $\vec{a}, \vec{b}, \vec{c}$  vektorlar bazis tashkil etishini ko'rsating va bu bazisda  $\vec{d}$  vektorning koordinatalarini toping:

1.  $\vec{a}(1, 2, 3)$ ,  $\vec{b}(-1, 3, 2)$ ,  $\vec{c}(7, -3, 5)$ ,  $\vec{d}(6, 10, 17)$
2.  $\vec{a}(4, 2, 5)$ ,  $\vec{b}(0, 7, 2)$ ,  $\vec{c}(0, 2, 7)$ ,  $\vec{d}(1, 5, 1)$
3.  $\vec{a}(4, 7, 8)$ ,  $\vec{b}(9, 1, 3)$ ,  $\vec{c}(2, -4, 1)$ ,  $\vec{d}(1, -13, -13)$
4.  $\vec{a}(2, 2, 3)$ ,  $\vec{b}(4, 6, 10)$ ,  $\vec{d}(7, 4, 11)$ ,  $\vec{d}(3, -2, 1)$
5.  $\vec{a}(10, 3, 1)$ ,  $\vec{b}(1, 4, 2)$ ,  $\vec{c}(3, 9, 2)$ ,  $\vec{d}(19, 30, 7)$
6.  $\vec{a}(2, 4, 1)$ ,  $\vec{b}(1, 3, 6)$ ,  $\vec{c}(5, 3, 1)$ ,  $\vec{d}(24, 20, 6)$
7.  $\vec{a}(1, -2, 3)$ ,  $\vec{b}(4, 7, 2)$ ,  $\vec{c}(6, 4, 2)$ ,  $\vec{d}(14, 18, 6)$
8.  $\vec{a}(1, 4, 3)$ ,  $\vec{b}(6, 8, 5)$ ,  $\vec{c}(3, 1, 4)$ ,  $\vec{d}(21, 18, 23)$
9.  $\vec{a}(2, 7, 3)$ ,  $\vec{b}(3, 1, 8)$ ,  $\vec{c}(2, -7, 4)$ ,  $\vec{d}(16, 14, 27)$
10.  $\vec{a}(7, 2, 1)$ ,  $\vec{b}(4, 3, 5)$ ,  $\vec{c}(3, 4, -2)$ ,  $\vec{d}(2, -5, -13)$
11.  $\vec{a}(1, 7, 3)$ ,  $\vec{b}(3, 4, 2)$ ,  $\vec{c}(4, 8, 5)$ ,  $\vec{d}(7, 32, 14)$
12.  $\vec{a}(-1, 0, 2)$ ,  $\vec{b}(1, 1, 1)$ ,  $\vec{c}(4, 3, -1)$ ,  $\vec{d}(1, 3, 3)$
13.  $\vec{a}(1, 3, 2)$ ,  $\vec{b}(-1, 0, 1)$ ,  $\vec{c}(2, -1, 1)$ ,  $\vec{d}(2, 1, -2)$
14.  $\vec{a}(9, 1, 3)$ ,  $\vec{b}(2, -4, 1)$ ,  $\vec{c}(4, 7, 8)$ ,  $\vec{d}(1, -3, -3)$
15.  $\vec{a}(2, 4, 1)$ ,  $\vec{b}(5, 3, 1)$ ,  $\vec{c}(1, 3, 6)$ ,  $\vec{d}(4, 10, 6)$
16.  $\vec{a}(6, 8, 5)$ ,  $\vec{b}(1, 4, 3)$ ,  $\vec{c}(3, 1, 4)$ ,  $\vec{d}(1, 1, 2)$
17.  $\vec{a}(2, 3, 2)$ ,  $\vec{b}(7, 1, -7)$ ,  $\vec{c}(3, 8, 4)$ ,  $\vec{d}(8, 7, 9)$

18.  $\bar{a}(-1,1,2)$ ,  $\bar{b}(0,1,3)$ ,  $\bar{c}(2,1,-1)$ ,  $\bar{d}(3,3,1)$   
 19.  $\bar{a}(1,-1,2)$ ,  $\bar{b}(3,0,-1)$ ,  $\bar{c}(2,1,1)$ ,  $\bar{d}(-2,1,2)$   
 20.  $\bar{a}(2,5,1)$ ,  $\bar{b}(4,3,3)$ ,  $\bar{c}(1,1,6)$ ,  $\bar{d}(2,5,3)$ .

2. (21-40)  $A_1$ ,  $A_2$ ,  $A_3$ ,  $A_4$  piramida uchlarining koordinatalari berilgan. Toping:

- $A_1A_2$  qirrasining uzunligini,  
 $A_1A_2$  va  $A_1A_4$  qirralari orasidagi burchakni,  
 $A_1A_4$  qirrasini bilan  $A_1$ ,  $A_2$ ,  $A_3$  yoq orasidagi burchakni,  
 $A_1$ ,  $A_2$ ,  $A_3$  yoq yuzasini, piramida hajmini,  
 $A_1A_2$  qirrasini yotgan to'g'ri chiziq tenglamasini,  
 $A_1A_2A_3$  tekisligining tenglamasini,  
 $A_4$  uchidan  $A_1A_2A_3$  yoqqa tushirilgan balandlik tenglamasini.
21.  $A_1(4;2;5)$ ,  $A_2(0;7;2)$ ,  $A_3(0;21;7)$ ,  $A_4(1;5;0)$   
 22.  $A_1(4;4;10)$ ,  $A_2(4;10;2)$ ,  $A_3(2;8;4)$ ,  $A_4(9;6;4)$   
 23.  $A_1(4;6;5)$ ,  $A_2(6;9;4)$ ,  $A_3(2;10;10)$ ,  $A_4(7;5;9)$   
 24.  $A_1(3;5;4)$ ,  $A_2(8;7;4)$ ,  $A_3(5;10;4)$ ,  $A_4(4;7;8)$   
 25.  $A_1(10;6;6)$ ,  $A_2(-2;8;2)$ ,  $A_3(6;8;9)$ ,  $A_4(7;10;3)$   
 26.  $A_1(1;8;2)$ ,  $A_2(5;2;6)$ ,  $A_3(5;7;4)$ ,  $A_4(4;10;9)$   
 27.  $A_1(6;6;5)$ ,  $A_2(4;9;5)$ ,  $A_3(4;6;11)$ ,  $A_4(6;9;3)$   
 28.  $A_1(7;2;2)$ ,  $A_2(5;7;7)$ ,  $A_3(5;3;1)$ ,  $A_4(2;3;7)$   
 29.  $A_1(8;6;4)$ ,  $A_2(10;5;5)$ ,  $A_3(5;6;8)$ ,  $A_4(8;10;7)$   
 30.  $A_1(7;7;3)$ ,  $A_2(6;5;8)$ ,  $A_3(3;5;8)$ ,  $A_4(8;4;1)$   
 31.  $A_1(2;3;0)$ ,  $A_2(2;0;-5)$ ,  $A_3(0;3;-5)$ ,  $A_4(2;3;-5)$   
 32.  $A_1(3;3;1)$ ,  $A_2(7;2;7)$ ,  $A_3(5;3;1)$ ,  $A_4(1;1;8)$   
 33.  $A_1(4;9;5)$ ,  $A_2(4;6;11)$ ,  $A_3(6;6;5)$ ,  $A_4(6;9;3)$   
 34.  $A_1(2;2;7)$ ,  $A_2(7;7;5)$ ,  $A_3(3;1;5)$ ,  $A_4(3;7;2)$   
 35.  $A_1(4;6;8)$ ,  $A_2(5;5;10)$ ,  $A_3(8;6;5)$ ,  $A_4(7;10;8)$   
 36.  $A_1(2;-3;2)$ ,  $A_2(7;1;0)$ ,  $A_3(1;2;3)$ ,  $A_4(3;2;7)$

$$37. A_1(1;2;3), A_2(4;2;5), A_3(4;7;8), A_4(2;2;3)$$

$$38. A_1(-1;3;2), A_2(0;7;2), A_3(9;1;3), A_4(4;6;10)$$

$$39. A_1(1;-2;3), A_2(1;4;3), A_3(2;7;3), A_4(7;2;1)$$

$$40. A_1(1;3;2), A_2(9;1;3), A_3(2;4;1), A_4(6;8;5)$$

3. (41-60) Uch noma'lumli uchta chiziqli tenglamalar sistemasi berilgan. Bu tenglamalar sistemasining birgalikdaligini tekshiring va uni quyidagi usullar bilan yeching:

1) Kramer usuli 2) Gauss usuli

$$41. \begin{cases} 3x_1 + 2x_2 + x_3 = 5 \\ 2x_1 + 3x_2 + x_3 = 1 \\ 2x_1 + x_2 + 3x_3 = 11 \end{cases}$$

$$42. \begin{cases} x_1 - 2x_2 + 3x_3 = 6 \\ 2x_1 - 3x_2 - 4x_3 = 20 \\ 3x_1 - 2x_2 - 5x_3 = 6 \end{cases}$$

$$43. \begin{cases} 4x_1 - 3x_2 + 2x_3 = 9 \\ 2x_1 + 5x_2 - 3x_3 = 4 \\ 5x_1 + 6x_2 - 2x_3 = 18 \end{cases}$$

$$44. \begin{cases} x_1 + x_2 + 2x_3 = -1 \\ 2x_1 - x_2 + 2x_3 = -4 \\ 4x_1 + x_2 + 4x_3 = -2 \end{cases}$$

$$45. \begin{cases} 2x_1 - x_2 - x_3 = 4 \\ 3x_1 + 4x_2 - 2x_3 = 11 \\ 3x_1 - 2x_2 + 4x_3 = 11 \end{cases}$$

$$46. \begin{cases} 3x_1 + 4x_2 + 2x_3 = 8 \\ 2x_1 - x_2 - 3x_3 = -4 \\ x_1 + 5x_2 + x_3 = 0 \end{cases}$$

$$47. \begin{cases} x_1 + x_2 + x_3 = 1 \\ 8x_1 + 3x_2 - 6x_3 = 2 \\ 4x_1 + x_2 - 3x_3 = 3 \end{cases}$$

$$48. \begin{cases} x_1 - 4x_2 - 2x_3 = -3 \\ 3x_1 + x_2 + x_3 = 5 \\ 3x_1 - 5x_2 - 6x_3 = -9 \end{cases}$$

$$49. \begin{cases} 7x_1 - 5x_2 = 31 \\ 4x_1 + 11x_3 = -43 \\ 2x_1 + 3x_2 + 4x_3 = -20 \end{cases}$$

$$50. \begin{cases} x_1 + 2x_2 + 4x_3 = 31 \\ 5x_1 + x_2 + 2x_3 = 20 \\ 3x_1 - x_2 + x_3 = 9 \end{cases}$$

$$51. \begin{cases} x_1 - x_2 + x_3 = 6 \\ 2x_1 + x_2 + x_3 = 3 \\ x_1 + x_2 + x_3 = 5 \end{cases}$$

$$52. \begin{cases} x_1 + x_2 - x_3 = 2 \\ -2x_1 + x_2 + x_3 = 3 \\ x_1 + x_2 + x_3 = 6 \end{cases}$$



$$53. \begin{cases} 3x_1 - x_2 = 5 \\ -2x_1 + x_2 + x_3 = 0 \\ 2x_1 - x_2 + 4x_3 = 15 \end{cases}$$

$$54. \begin{cases} 5x_1 + 4x_3 = 1 \\ x_1 - x_2 + 2x_3 = 0 \\ 4x_1 + x_2 + 2x_3 = 1 \end{cases}$$

$$55. \begin{cases} 2x_1 + 2x_2 - x_3 = 4 \\ 3x_1 + x_2 - 3x_3 = 7 \\ x_1 + x_2 + 2x_3 = 3 \end{cases}$$

$$56. \begin{cases} x_1 + x_2 + x_3 = 1 \\ x_1 + 2x_2 + 2x_3 = 2 \\ 2x_1 + 3x_2 + 3x_3 = 3 \end{cases}$$

$$57. \begin{cases} 2x_1 + 3x_2 + 5x_3 = 10 \\ 3x_1 + 7x_2 + 4x_3 = 3 \\ x_1 + 2x_2 + 2x_3 = 3 \end{cases}$$

$$58. \begin{cases} 5x_1 - 6x_2 + 4x_3 = 3 \\ 3x_1 - 3x_2 + 2x_3 = 2 \\ 4x_1 - 5x_2 + 2x_3 = 1 \end{cases}$$

$$59. \begin{cases} 4x_1 - 3x_2 + 2x_3 = -4 \\ 6x_1 - 2x_2 + 3x_3 = -1 \\ 5x_1 - 3x_2 + 2x_3 = -3 \end{cases}$$

$$60. \begin{cases} 5x_1 + 2x_2 + 3x_3 = -2 \\ 2x_1 - 2x_2 + 5x_3 = 0 \\ 3x_1 + 4x_2 + 2x_3 = -10 \end{cases}$$

4. (61-80) Quyidagi tenglamalar qanday sirtni ifodalaydi?

$$61. x^2 + y^2 = 16$$

$$62. \frac{x^2}{6} + \frac{z^2}{4} = 1$$

$$63. x = 2 \cdot z^2$$

$$64. \frac{z^2}{5} - \frac{x^2}{7} = 1$$

$$65. x^2 + y^2 - z^2 = 0$$

$$66. z = x^2 + y^2$$

$$67. y^2 + z^2 - \frac{x^2}{4} = 0$$

$$68. \frac{x^2 + z^2}{6} - \frac{y^2}{15} = -1$$

$$69. \frac{x^2}{6} - \frac{y^2}{5} + \frac{z^2}{1} - 1 = 0$$

$$70. -x^2 + \frac{y^2}{5} + \frac{z^2}{7} = 0$$

$$71. z = -(x^2 + y^2)$$

$$72. z = 1 - x^2 - y^2$$

$$73. 2x^2 - 5y^2 - 8 = 0$$

$$74. 4x^2 - 8y^2 + 16z^2 = 0$$

$$75. y^2 = 6x - 4$$

76.  $3x^2 + 5y^2 = 12z$

77.  $x^2 + 4y^2 - 8 = 0$

78.  $2x^2 - 3z^2 = -12y$

79.  $4x^2 - 12y^2 - 6z^2 = 12$

80.  $z^2 - 4x = 0$

5.(81-100) Berilgan matritsalarining xos son va xos vektorlarini toping:

81. 
$$\begin{pmatrix} 2 & 19 & 30 \\ 0 & -5 & -12 \\ 0 & 2 & 5 \end{pmatrix}$$

82. 
$$\begin{pmatrix} 2 & 19 & 30 \\ 0 & -5 & -12 \\ 0 & 2 & 5 \end{pmatrix}$$

83. 
$$\begin{pmatrix} 2 & 19 & 30 \\ 0 & -5 & -12 \\ 0 & 2 & 5 \end{pmatrix}$$

84. 
$$\begin{pmatrix} 2 & 19 & 30 \\ 0 & -5 & -12 \\ 0 & 2 & 5 \end{pmatrix}$$

85. 
$$\begin{pmatrix} 2 & 19 & 30 \\ 0 & -5 & -12 \\ 0 & 2 & 5 \end{pmatrix}$$

86. 
$$\begin{pmatrix} 2 & 19 & 30 \\ 0 & -5 & -12 \\ 0 & 2 & 5 \end{pmatrix}$$

87. 
$$\begin{pmatrix} 2 & 19 & 30 \\ 0 & -5 & -12 \\ 0 & 2 & 5 \end{pmatrix}$$

88. 
$$\begin{pmatrix} 2 & 19 & 30 \\ 0 & -5 & -12 \\ 0 & 2 & 5 \end{pmatrix}$$

89. 
$$\begin{pmatrix} 2 & 19 & 30 \\ 0 & -5 & -12 \\ 0 & 2 & 5 \end{pmatrix}$$

90. 
$$\begin{pmatrix} 2 & 19 & 30 \\ 0 & -5 & -12 \\ 0 & 2 & 5 \end{pmatrix}$$

91. 
$$\begin{pmatrix} 2 & 19 & 30 \\ 0 & -5 & -12 \\ 0 & 2 & 5 \end{pmatrix}$$

92. 
$$\begin{pmatrix} 2 & 19 & 30 \\ 0 & -5 & -12 \\ 0 & 2 & 5 \end{pmatrix}$$

$$93. \begin{pmatrix} 2 & 19 & 30 \\ 0 & -5 & -12 \\ 0 & 2 & 5 \end{pmatrix}$$

$$94. \begin{pmatrix} 2 & 19 & 30 \\ 0 & -5 & -12 \\ 0 & 2 & 5 \end{pmatrix}$$

$$95. \begin{pmatrix} 2 & 19 & 30 \\ 0 & -5 & -12 \\ 0 & 2 & 5 \end{pmatrix}$$

$$96. \begin{pmatrix} 2 & 19 & 30 \\ 0 & -5 & -12 \\ 0 & 2 & 5 \end{pmatrix}$$

$$97. \begin{pmatrix} 2 & 19 & 30 \\ 0 & -5 & -12 \\ 0 & 2 & 5 \end{pmatrix}$$

$$98. \begin{pmatrix} 2 & 19 & 30 \\ 0 & -5 & -12 \\ 0 & 2 & 5 \end{pmatrix}$$

$$99. \begin{pmatrix} 2 & 19 & 30 \\ 0 & -5 & -12 \\ 0 & 2 & 5 \end{pmatrix}$$

$$100. \begin{pmatrix} 2 & 19 & 30 \\ 0 & -5 & -12 \\ 0 & 2 & 5 \end{pmatrix}$$

### Matematik analizga kirish

6.(101-120) Lopital qoidasidan foydalanmay quyidagi funksiyalarning limitini hisoblang:

$$101. a) \lim_{x \rightarrow \infty} \frac{1-2x}{3x-2};$$

$$b) \lim_{x \rightarrow 0} \frac{1-\cos x}{5x^2};$$

$$102. a) \lim_{x \rightarrow \infty} \frac{x^j+1}{2x^3+1};$$

$$b) \lim_{x \rightarrow 0} \frac{1-\cos x}{5x^2};$$

$$103. a) \lim_{x \rightarrow \infty} \frac{2x^3+x^2-5}{x^3+x-2};$$

$$b) \lim_{x \rightarrow 0} \frac{\sqrt{1+x}-\sqrt{1-x}}{3x};$$

$$c) \lim_{x \rightarrow \infty} \left(\frac{x+3}{x-2}\right)^x;$$

$$b) \lim_{x \rightarrow 7} \frac{\sqrt{2+x}-3}{x-7};$$

$$c) \lim_{x \rightarrow \infty} \left(\frac{2x-1}{2x+1}\right)^x;$$

$$b) \lim_{x \rightarrow 1} \frac{x-\sqrt{x}}{x^2-x};$$

$$\begin{array}{ll}
 \text{104. a) } \lim_{x \rightarrow 0} \frac{\sqrt{1 - \cos 2x}}{|x|}; & \text{z) } \lim_{x \rightarrow x} \left( \frac{4x+1}{4x} \right)^{2x}. \\
 \text{a) } \lim_{x \rightarrow \infty} \frac{3x^4 + x^2 - 6}{2x^4 - x + 2}; & \text{b) } \lim_{x \rightarrow 0} \frac{x}{\sqrt{1+3x-1}}; \\
 \text{b) } \lim_{x \rightarrow 0} \frac{5x}{\arctg x}; & \text{z) } \lim_{x \rightarrow 0} (1+2x)^{\frac{1}{x}}. \\
 \text{105. a) } \lim_{x \rightarrow \infty} \frac{2x^2 + 6x - 5}{5x^2 - x - 1}; & \text{b) } \lim_{x \rightarrow 0} \frac{1 - \sqrt{1-x^2}}{x^2}; \\
 \text{b) } \lim_{x \rightarrow 0} \frac{\cos x - \cos^3 x}{x^2}; & \text{z) } \lim_{x \rightarrow \infty} x [\ln(x+1) - \ln x]. \\
 \text{106. a) } \lim_{x \rightarrow \infty} \frac{3-x+5x^4}{x^4 - 12x + 1}; & \text{b) } \lim_{x \rightarrow 0} \frac{\sqrt{1+3x} - \sqrt{1-2x}}{x+x^2}; \\
 \text{b) } \lim_{x \rightarrow 0} \frac{x^2 \operatorname{ctg} 2x}{\sin 3x}; & \text{z) } \lim_{x \rightarrow \infty} (2x+1) [\ln(x+3) - \ln x]. \\
 \text{107. a) } \lim_{x \rightarrow \infty} \frac{x - 2x^2 + 5x^4}{2 + 3x^2 + x^4}; & \text{b) } \lim_{x \rightarrow 0} \frac{\sqrt{1+3x^2} - 1}{x^2 + x^3}; \\
 \text{b) } \lim_{x \rightarrow 0} \frac{1 - \cos 6x}{1 - \cos 2x}; & \text{z) } \lim_{x \rightarrow \infty} (x-5) [\ln(x-3) - \ln x]. \\
 \text{108. a) } \lim_{x \rightarrow \infty} \frac{5x^2 - 3x + 1}{3x^2 + x - 5}; & \text{b) } \lim_{x \rightarrow 3} \frac{\sqrt{2x-1} - \sqrt{5}}{x-3}; \\
 \text{b) } \lim_{x \rightarrow 0} \frac{\operatorname{tg}^2 \frac{x}{2}}{x^2}; & \text{z) } \lim_{x \rightarrow 1} (7-6x)^{\frac{1}{1-x}}. \\
 \text{109. a) } \lim_{x \rightarrow \infty} \frac{7x^4 - 2x^3 + 2}{x^4 + 3}; & \text{b) } \lim_{x \rightarrow 5} \frac{\sqrt{1+3x} - \sqrt{2x+6}}{x^2 - 5x}; \\
 \text{b) } \lim_{x \rightarrow 0} \frac{1 - \cos 4x}{2x \operatorname{tg} 2x}; & \text{z) } \lim_{x \rightarrow 2} (3x-5)^{\frac{2x}{x^2-1}}.
 \end{array}$$

$$110. a) \lim_{x \rightarrow \infty} \frac{8x^5 - 3x^2 + 9}{2x^5 + 2x^2 + 5};$$

$$b) \lim_{x \rightarrow 0} 5x \operatorname{ctg} 3x;$$

$$b) \lim_{x \rightarrow 2} \frac{x-2}{\sqrt{2x-2}};$$

$$z) \lim_{x \rightarrow 3} (3x-8)^{\frac{1}{x-3}}.$$

$$111. a) \lim_{x \rightarrow \infty} \frac{x^2 + x + 1}{(x-1)^2};$$

$$b) \lim_{x \rightarrow 0} \frac{\sqrt{1+x} - 1}{x};$$

$$z) \lim_{x \rightarrow \infty} \left( \frac{x-3}{x+2} \right)^{2x+1};$$

$$112. a) \lim_{x \rightarrow \infty} \frac{1-x-x^2}{x^3+3};$$

$$b) \lim_{x \rightarrow \infty} (x - \sqrt{x^2 + 5x});$$

$$z) \lim_{x \rightarrow \infty} \left( \frac{2x-5}{2x+1} \right)^{x-1}.$$

$$113. a) \lim_{x \rightarrow -2} \frac{x^3 + 4x^2 + 4x}{x^2 - x - 6};$$

$$b) \lim_{x \rightarrow \infty} (\sqrt{x^2 + 2x} - \sqrt{x^2 + x});$$

$$z) \lim_{x \rightarrow \pi} (1 + 3 \operatorname{tg} x)^{\operatorname{ctg} x}.$$

$$114. a) \lim_{x \rightarrow \infty} \frac{(2x+3)^3(3x-2)^2}{x^5+5};$$

$$b) \lim_{x \rightarrow 4} \frac{3 - \sqrt{5+x}}{1 - \sqrt{5-x}};$$

$$z) \lim_{x \rightarrow \infty} \left( \frac{1}{x^2} \right)^{\frac{2x}{x+1}}.$$

$$115. a) \lim_{x \rightarrow -1} \frac{x^2 - 1}{x^2 + 3x + 2};$$

$$b) \lim_{x \rightarrow 0} \frac{\sqrt{1+x+x^2} - 1}{x};$$

$$z) \lim_{x \rightarrow 1} \frac{\cos \frac{\pi}{2}}{1 - \sqrt{x}};$$

$$z) \lim_{x \rightarrow 1} \left( \frac{x-1}{x^2-1} \right)^{x+1}.$$

$$116. a) \lim_{x \rightarrow \infty} \frac{2x^2 - 3x - 4}{\sqrt{x^4 + 1}};$$

$$b) \lim_{x \rightarrow a} \frac{\sin x - \sin a}{x - a};$$

$$117. a) \lim_{x \rightarrow \infty} \frac{\sqrt{x^2 + 1} + \sqrt{x}}{\sqrt{x^3 + 1} - x};$$

$$b) \lim_{x \rightarrow 2} \frac{x^2 - 4}{\operatorname{arctg}(x + 2)};$$

$$118. a) \lim_{x \rightarrow \infty} \frac{\sqrt{x^2 + 1}}{\sqrt[3]{x^3 + 1}};$$

$$b) \lim_{x \rightarrow -1} \left[ \frac{1}{1-x} - \frac{3}{1-x^3} \right];$$

$$119. a) \lim_{x \rightarrow 2} \left[ \frac{3x^2 + x}{(x-2)(x^2 + x + 1)} - \frac{2}{x-2} \right];$$

$$b) \lim_{x \rightarrow -1} \frac{\sqrt[3]{1+2x+1}}{\sqrt{2+x+x^2}};$$

$$120. a) \lim_{x \rightarrow 1} \frac{x^3 - 6x^2 + 11x - 6}{x^2 - 3x + 2};$$

$$b) \lim_{x \rightarrow 2} \left( \frac{x}{2} \right)^{\frac{1}{x-2}}.$$

7. (121-140)  $y=f(x)$  funksiya berilgan. Bu funksiyaning uzilish nuqtalarini toping (agar mavjud bo'lsa) va turini aniqlang. Chizmasini yasang:

$$121. f(x) = \begin{cases} x+4, & x < -1 \\ x^2+2, & -1 \leq x < 1 \\ 2x, & x \geq 1 \end{cases}$$

$$122. f(x) = \begin{cases} x+2, & x < -1 \\ x^2+1, & -1 \leq x < 1 \\ -x+3, & x \geq 1 \end{cases}$$

$$123. f(x) = \begin{cases} -x, & x \leq 0 \\ -(x-1)^2, & 0 < x < 2 \\ x-3, & x \geq 2 \end{cases}$$

$$124. f(x) = \begin{cases} \cos x, & x \leq 0 \\ x^2+1, & 0 < x < 1 \\ x, & x \geq 1 \end{cases}$$

$$125. f(x) = \begin{cases} -x, & x \leq 0 \\ x^2, & 0 < x \leq 2 \\ x+1, & x > 2 \end{cases}$$

$$126. f(x) = \begin{cases} -x, & x \leq 0 \\ \sin x, & 0 < x \leq \pi \\ x-2, & x > \pi \end{cases}$$

$$127. f(x) = \begin{cases} -(x+1), & x \leq -1 \\ (x+2)^2, & -1 < x \leq 0 \\ x, & x > 0 \end{cases}$$

$$128. f(x) = \begin{cases} -x^2, & x \leq 0 \\ \operatorname{tg} x, & 0 < x \leq \frac{\pi}{4} \\ 2, & x > \frac{\pi}{4} \end{cases}$$

$$129. f(x) = \begin{cases} -2x, & x \leq 0 \\ x^2+1, & 0 < x \leq 1 \\ 2, & x > 1 \end{cases}$$

$$130. f(x) = \begin{cases} -2x, & x \leq 0 \\ \sqrt{x}, & 0 < x < 4 \\ 1, & x \geq 4 \end{cases}$$

$$131. f(x) = \begin{cases} -\frac{1}{2}x^2, & x \leq 2 \\ x, & x > 2 \end{cases}$$

$$132. f(x) = \begin{cases} 2\sqrt{x}, & 0 \leq x \leq 1 \\ 4-2x, & 1 < x < 2,5 \\ 2x-7, & 2,5 \leq x < \infty \end{cases}$$

$$133. f(x) = \begin{cases} 2x+5, & -\infty < x < -1 \\ \frac{1}{x}, & -1 \leq x < \infty \end{cases}$$

$$134. f(x) = \begin{cases} -x, & x \leq -1 \\ \frac{2}{x-1}, & x > -1 \end{cases}$$

$$135. f(x) = \begin{cases} 1-x^2, & x < 0 \\ (x-1)^2, & 0 \leq x \leq 2 \\ 4-x, & x > 2 \end{cases}$$

$$136. f(x) = \begin{cases} x^2, & x \leq 3 \\ 2x+1, & x > 3 \end{cases}$$

$$137. f(x) = \begin{cases} x^2, & x \leq 0 \\ \sin x, & 0 < x \leq \pi \\ x-1, & x > \pi \end{cases}$$

$$138. f(x) = \begin{cases} x^2, & x \leq 0 \\ 1-x, & 0 < x < 4 \\ \sqrt{x}, & x \geq 4 \end{cases}$$

$$140. f(x) = \begin{cases} -x^2, & x \leq 0 \\ x+1, & 0 < x \leq 2 \\ 3, & x > 2 \end{cases}$$

$$139. f(x) = \begin{cases} 2\sqrt{x}, & 0 \leq x < 4 \\ x+1, & 4 \leq x < 5 \\ 6, & x \geq 5 \end{cases}$$

### Bir o'zgaruvchili funksiyaning differensial hisobi

8.(141-160) Berilgan funksiyalarning hosilasini toping:

$$141. a) y = (1 + \sqrt[3]{x})^3;$$

$$b) y = (e^{\cos x} + 3)^2$$

$$b) y = (\ln \sin(2x + 5));$$

$$r) y = x^{x^x}.$$

$$142. a) y = x^2 \sqrt{1-x^2};$$

$$b) y = \frac{4(\sin x)}{\cos^2 x};$$

$$b) y = \arctg(e^{2x});$$

$$r) y = x^{\frac{1}{x}}.$$

$$143. a) y = x \sqrt{\frac{1+x^2}{1-x}};$$

$$b) y = \frac{1}{\operatorname{tg}^2 2x};$$

$$b) y = \arcsin \sqrt{1-3x};$$

$$r) y = x^{\ln x}.$$

$$144. a) y = \frac{3+6x}{\sqrt{3-4x+5x^2}};$$

$$b) y = \sin x - x \cdot \cos x;$$

$$b) y = x^m \cdot \ln x;$$

$$r) y = x^{-\operatorname{tg} x}.$$

$$145. a) y = \frac{x}{\sqrt{a^2 - x^2}};$$

$$b) y = \frac{(\sin^2 x)}{(2 + 3 \cos^2 x)};$$

$$b) y = \frac{x \cdot \ln x}{x-1};$$

$$r) y = (\operatorname{arctg} x)^{\ln x}.$$



$$146. \text{ a) } y = \frac{1}{\sqrt{x^2 + 1}} + 5 \cdot \sqrt[5]{x^3 + 1};$$

$$\text{b) } y = 3^{\arctg x^3};$$

$$147. \text{ a) } y = \sqrt[3]{\frac{1+x^2}{1-x^2}};$$

$$\text{b) } y = \arctg \frac{x}{1 + \sqrt{1-x^2}};$$

$$148. \text{ a) } y = 3 \cdot \sqrt[3]{x^5 + 5x^4 - \frac{5}{x}};$$

$$\text{b) } y = \arctg(\tg^2 x);$$

$$149. \text{ a) } y = 5 \cdot \sqrt[5]{x^5 + x + \frac{1}{x}};$$

$$\text{b) } y = \frac{(\arcsin x)}{\sqrt{1-x^2}};$$

$$150. \text{ a) } y = \sqrt{x^2 + 1} + \sqrt[3]{x^3 + 1};$$

$$\text{b) } y = \arctg \sqrt{\frac{3-x}{x-2}};$$

$$151. \text{ a) } y = \frac{4}{3} \cdot \sqrt[4]{\frac{x-1}{x+2}};$$

$$\text{b) } y = \sin^2(x^3);$$

$$152. \text{ a) } y = \frac{x(x^2 + 1)}{1-x^2};$$

$$\text{b) } y = \arctg \frac{x \cdot \sin \alpha}{1 - x \cdot \cos \alpha};$$

$$153. \text{ a) } y = \frac{x^3}{3 \cdot \sqrt{(1+x^2)^3}};$$

$$\text{б) } y = 2 \cdot \tg^3(x^2 + 1);$$

$$\text{г) } y = (\arctg x)^x.$$

$$\text{б) } y = \frac{1}{2} \tg^2 x + \ln \cos x;$$

$$\text{г) } y = (x + x^2)^x.$$

$$\text{б) } y = \ln \sqrt{\frac{1 - \sin x}{1 + \sin x}};$$

$$\text{г) } y = (\sin x)^{\ln x}.$$

$$\text{б) } y = 2^x \cdot e^{-x};$$

$$\text{г) } y = (\cos x)^x.$$

$$\text{б) } y = \frac{1}{3} \tg^3 x - \tg x + x;$$

$$\text{г) } y = (\cos x)^{x^2}.$$

$$\text{б) } y = \arcsin(\ln x);$$

$$\text{г) } y = (\sin x)^x.$$

$$\text{б) } y = e^{\sin^2 x};$$

$$\text{г) } y = x^{e^x}.$$

$$\text{б) } y = \sqrt{\cos x} \cdot \alpha^{\sqrt{\cos x}};$$

$$b) y = \ln(\arcsin 5x);$$

$$154. a) y = (a+x)\sqrt{a-x};$$

$$b) y = \arccos \sqrt{x};$$

$$155. a) y = \sqrt{\frac{x(x-1)}{x-2}};$$

$$b) y = \arcsin \sqrt{\sin x};$$

$$156. a) y = \sqrt[3]{2+x^4};$$

$$b) y = \arcsin \sqrt{x};$$

$$157. a) y = \frac{2x}{\sqrt{1-x^2}};$$

$$b) y = \sqrt{1 + \arcsin x};$$

$$158. a) y = x^2 \cdot \sqrt[3]{x^2};$$

$$b) y = \frac{1}{\operatorname{arctg} x};$$

$$159. a) y = \frac{(x-1)\sqrt[3]{x+1}}{x-2};$$

$$b) y = \frac{(1+x^2)\operatorname{arctg} x}{2};$$

$$160. a) y = \frac{\sqrt{2x^2 - 2x + 1}}{x};$$

$$b) y = \frac{1}{2}(\arcsin x)^2 \arccos x;$$

$$r) y = \sqrt[x]{x};$$

$$b) y = \frac{1 + \cos 2x}{1 - \cos 2x};$$

$$r) y = x^{x^2};$$

$$b) y = \sqrt{\cos 4x};$$

$$r) y = \left(\frac{x}{a}\right)^{ax};$$

$$b) y = \sin(ax) \cdot \cos \frac{x}{a};$$

$$r) y = \left(1 + \frac{1}{x}\right)^x;$$

$$b) y = \frac{1}{3\cos^2 x} - \frac{1}{\cos x};$$

$$r) y = (\cos x)^{\sin 2x};$$

$$b) y = \sin(x \cdot \cos x);$$

$$r) y = (\sin x)^{\cos x};$$

$$b) y = \sin^2(x^2 - 5x + 1);$$

$$r) y = x^{\sqrt{x}};$$

$$b) y = \operatorname{tg}^2 5x;$$

$$r) y = x^{\ln 3x};$$

9.(161-180) Berilgan funksiyalar uchun  $\frac{dy}{dx}$  va  $\frac{d^2y}{dx^2}$  lar

topilsin:

161. a)  $y = \frac{x}{x^2 - 1}$ ;

б)  $\begin{cases} x = \cos \frac{t}{2} \\ y = t - \sin t \end{cases}$

162. a)  $y = \ln \operatorname{ctg} 2x$ ;

б)  $\begin{cases} x = t^3 + 8t \\ y = t^5 + 2t \end{cases}$

163. a)  $y = x^3 \ln x$ ;

б)  $\begin{cases} x = t - \sin t \\ y = 1 - \cos t \end{cases}$

164. a)  $y = x \cdot \operatorname{arctg} x$ ;

б)  $\begin{cases} x = e^{2t} \\ y = \cos t \end{cases}$

165. a)  $y = \operatorname{arctg} x$ ;

б)  $\begin{cases} x = 3 \cos^2 t \\ y = 2 \sin^3 t \end{cases}$

166. a)  $y = e^{\operatorname{ctg} 3x}$ ;

б)  $\begin{cases} x = 3 \cos t \\ y = 4 \sin^2 t \end{cases}$

167. a)  $y = e^x \cdot \cos x$ ;

б)  $\begin{cases} x = 3t - t^3 \\ y = 3t^2 \end{cases}$

168. a)  $y = e^{-x} \cdot \sin x$ ;

б)  $\begin{cases} x = 2t - t^3 \\ y = 2t^2 \end{cases}$

169. a)  $y = x \cdot \sqrt{1 + x^2}$ ;

б)  $\begin{cases} x = t + \ln \cos t \\ y = t - \ln \sin t \end{cases}$

$$170. \text{ a) } y = x \cdot e^{-x^2};$$

$$\text{б) } \begin{cases} x = \ln t \\ y = \frac{t + \frac{1}{t}}{2} \end{cases}$$

$$171. \text{ a) } y = x^2 + \sin 5x;$$

$$\text{б) } \begin{cases} x = \cos t + t \sin t \\ y = \sin t - t \cos t \end{cases}$$

$$172. \text{ a) } y = x^5 \cdot \ln x;$$

$$\text{б) } \begin{cases} x = a \cdot \cos^3 t \\ y = a \cdot \sin^3 t \end{cases}$$

$$173. \text{ a) } y = x \cdot \sin x;$$

$$\text{б) } \begin{cases} x = \frac{3at}{1+t^3} \\ y = \frac{3at}{1+t^3} \end{cases}$$

$$174. \text{ a) } y = x^2 \cdot e^{3x};$$

$$\text{б) } \begin{cases} x = t^2 + 2t \\ y = \ln(t+1) \end{cases}$$

$$175. \text{ a) } y = \sin x \cdot \cos^2 x;$$

$$\text{б) } \begin{cases} x = a(t - \sin t) \\ y = a(1 - \cos t) \end{cases}$$

$$176. \text{ a) } y = \sin 3x \cdot \sin^2 x;$$

$$\text{б) } \begin{cases} x = 2 \sin t + \sin 2t \\ y = 2 \cos t + \cos 2t \end{cases}$$

$$177. \text{ a) } y = \log(x^2 - 3x + 2);$$

$$\text{б) } \begin{cases} x = \arcsin \sqrt{t} \\ y = \arcsin \sqrt{1-t^2} \end{cases}$$

$$178. \text{ a) } y = x^3 \cdot \lg x;$$

$$\text{б) } \begin{cases} x = a \cos t \\ y = b \sin t \end{cases}$$

$$179. \text{ a) } y = \sin^4 x + \cos^4 x;$$

$$\text{б) } \begin{cases} x = \ln t \\ y = t^3 \end{cases}$$

$$180. a) y = \ln \sqrt[3]{1+x^2};$$

$$b) \begin{cases} x = \arcsin t \\ y = \sqrt{1-t^2} \end{cases}$$

10. (181-200) Lopital qoidasidan foydalanib quyidagi limitlarni hisoblang:

$$181. a) \lim_{x \rightarrow \pi} \frac{2^{\cos^2 x} - 1}{\ln \sin x};$$

$$b) \lim_{x \rightarrow 0} \frac{e^x + e^{-x} - 2}{\sin^2 x};$$

$$b) \lim_{x \rightarrow 1} \left( \frac{3x-1}{x+1} \right)^{\frac{1}{\sqrt{x}-1}};$$

$$182. a) \lim_{x \rightarrow \frac{1}{2}} \frac{(2x-1)^2}{e^{\sin \pi x} - e^{-\sin 3\pi x}};$$

$$b) \lim_{x \rightarrow 0} \frac{1 + x \sin x - \cos 2x}{\sin^2 x};$$

$$b) \lim_{x \rightarrow \alpha} \left( \frac{\sin x}{\sin \alpha} \right)^{\frac{1}{x-\alpha}};$$

$$183. a) \lim_{x \rightarrow 2} \frac{\ln(x - \sqrt[3]{2x-3})}{\sin \frac{\pi x}{2} - \sin[(x-1)\pi]};$$

$$b) \lim_{x \rightarrow -1} \frac{x^3 + 1}{\sin(x+1)};$$

$$b) \lim_{x \rightarrow 1} \left( \frac{2x-1}{x} \right)^{\frac{1}{\sqrt{x}-1}};$$

$$184. a) \lim_{x \rightarrow 2} \frac{\operatorname{tg} x - \operatorname{tg} 2}{\sin \ln(x-1)};$$

$$b) \lim_{x \rightarrow a} \frac{\operatorname{tg} x - \operatorname{tg} a}{\ln x - \ln a};$$

$$b) \lim_{x \rightarrow 2} \left( \frac{\cos x}{\cos a} \right)^{\frac{1}{x-2}};$$

$$185. a) \lim_{x \rightarrow \frac{\pi}{2}} \frac{e^{\operatorname{tg} 2x} - e^{-\sin 2x}}{\sin x - 1};$$

$$b) \lim_{x \rightarrow 0} \frac{\sqrt{1+\operatorname{tg} x} - \sqrt{1+\sin x}}{x^3};$$

$$b) \lim_{x \rightarrow 8} \left( \frac{2x-7}{x+1} \right)^{\frac{1}{\sqrt{x}-2}};$$

$$186. \text{ a) } \lim_{x \rightarrow \frac{\pi}{6}} \frac{\ln \sin 3x}{(6x - \pi)^2};$$

$$\text{ b) } \lim_{x \rightarrow \frac{\pi}{4}} (\operatorname{tg} x) / \cos\left(\frac{3\pi}{4} - x\right).$$

$$\text{ б) } \lim_{x \rightarrow 0} \frac{x^2(e^x - e^{-x})}{e^{x^2-1} - e};$$

$$187. \text{ a) } \lim_{x \rightarrow 3} \frac{\sin(\sqrt{2x^2 - 3x - 5} - \sqrt{1+x})}{\ln(x-1) - \ln(x+1) + \ln 2}; \quad \text{ б) } \lim_{x \rightarrow 0} \frac{e^{\alpha x} - e^{\beta x}}{\sin \alpha x - \sin \beta x};$$

$$\text{ a) } \lim_{x \rightarrow 2} \left( \frac{\cos x}{\cos a} \right)^{\frac{1}{x-2}}.$$

$$188. \text{ a) } \lim_{x \rightarrow 2\pi} \frac{x - 2\pi}{\operatorname{tg}(\cos x - 1)};$$

$$\text{ б) } \lim_{x \rightarrow 0} \frac{\sqrt{1+x} \cdot \sin x - 1}{e^{x^2} - 1};$$

$$\text{ a) } \lim_{x \rightarrow a} \left( 2 - \frac{x}{a} \right)^{\operatorname{tg} \frac{\pi}{2a}}.$$

$$189. \text{ a) } \lim_{x \rightarrow \frac{1}{2}} \frac{\ln(4x-1)}{\sqrt{1-\cos \pi x} - 1};$$

$$\text{ б) } \lim_{x \rightarrow \frac{\pi}{3}} \frac{1 - 2 \cos x}{\sin(\pi - 3x)};$$

$$\text{ b) } \lim_{x \rightarrow 2\pi} (\cos x)^{\frac{\operatorname{ctg} 2x}{\sin 3x}}.$$

$$190. \text{ a) } \lim_{x \rightarrow -2} \frac{\arcsin \frac{x+2}{2}}{\sqrt{2+x+x^2} - 9};$$

$$\text{ б) } \lim_{x \rightarrow 1} \frac{1 - x^2}{\sin \pi x};$$

$$\text{ b) } \lim_{x \rightarrow 2\pi} (\cos x)^{\frac{1}{\sin^2 2x}}.$$

$$191. \text{ a) } \lim_{x \rightarrow 3} \frac{2^{\sin \pi x} - 1}{\ln(x^3 - 6x - 8)};$$

$$\text{ б) } \lim_{x \rightarrow \frac{\pi}{4}} \frac{\sin x - \cos x}{\ln \operatorname{tg} x};$$

$$\text{ b) } \lim_{x \rightarrow 3} \left( \frac{6-x}{3} \right)^{\operatorname{tg} \frac{\pi}{6}}.$$

$$192. \text{ a) } \lim_{x \rightarrow \pi} \frac{\ln \cos 2x}{\left(1 - \frac{\pi}{x}\right)^2};$$

$$\text{ б) } \lim_{x \rightarrow b} \frac{a^x - a^b}{x - b};$$

$$b) \lim_{x \rightarrow 4\pi} (\cos x)^{\frac{c \lg x}{\sin 4x}}$$

$$193. a) \lim_{x \rightarrow 2} \frac{\operatorname{tg} \ln(3x-5)}{e^{x+3} - e^{x^2+1}};$$

$$b) \lim_{x \rightarrow 0} \frac{1 - \cos 2x + \operatorname{tg}^2 x}{x \cdot \sin 3x};$$

$$b) \lim_{x \rightarrow 1} (3 - 2x)^{\operatorname{tg} \frac{\pi x}{2}}$$

$$194. a) \lim_{x \rightarrow 2\pi} \frac{\ln \cos x}{3^{\sin^2 x} - 1};$$

$$b) \lim_{x \rightarrow 0} \frac{\sin 2x - 2 \sin x}{x \cdot \ln \cos 5x};$$

$$b) \lim_{x \rightarrow 4\pi} (\cos x)^{\frac{5}{\lg 5x \sin 2x}}$$

$$195. a) \lim_{x \rightarrow 1} \frac{\sqrt[3]{1 + \ln^2 x} - 1}{1 + \cos \pi x}; \quad b) \lim_{h \rightarrow 0} \frac{\ln(x+h) + \ln(x-h) - 2 \ln x}{h^2};$$

$$b) \lim_{x \rightarrow 3} \left( \frac{9 - 2x}{3} \right)^{\operatorname{tg} \frac{\pi x}{6}}$$

$$196. a) \lim_{x \rightarrow \pi} \frac{\cos \frac{x}{2}}{e^{\sin x} - e^{\sin 4x}};$$

$$b) \lim_{x \rightarrow 1} \frac{1 - x}{\log_2 x};$$

$$b) \lim_{x \rightarrow \frac{\pi}{2}} (\sin x)^{6 \operatorname{tg} x \operatorname{tg} 3x}$$

$$197. a) \lim_{x \rightarrow 3} \frac{\ln(2x-5)}{e^{\sin 5x} - 1};$$

$$b) \lim_{x \rightarrow 0} \frac{e^{\sin 2x} - e^{\sin x}}{\operatorname{tg} x};$$

$$b) \lim_{x \rightarrow 1} (2e^{x-1} - 1)^{\frac{x}{x-1}}$$

$$198. a) \lim_{x \rightarrow \frac{\pi}{3}} \frac{e^{\sin^2 6x} - e^{\sin^2 3x}}{\log_3 \cos 6x};$$

$$b) \lim_{x \rightarrow 1} \frac{2^x - 2}{\ln x};$$

$$b) \lim_{x \rightarrow \frac{\pi}{2}} \left( \operatorname{tg} \frac{x}{2} \right)^{\frac{1}{1 - \frac{x}{2}}}$$

$$199. \text{ a) } \lim_{x \rightarrow \frac{\pi}{2}} \frac{e^{\sin 2x} - e^{\operatorname{tg} 2x}}{\ln \frac{2x}{\pi}}; \quad \text{б) } \lim_{h \rightarrow 0} \frac{\sin(x+h) - \sin(x-h)}{h};$$

$$\text{в) } \lim_{x \rightarrow 1} (2e^{x-1} - 1)^{\frac{3x-1}{x-1}}.$$

$$200. \text{ a) } \lim_{x \rightarrow -2} \frac{\operatorname{tg}(e^{x+2} - e^{x^2-4})}{\operatorname{tg} x + \operatorname{tg} 2};$$

$$\text{б) } \lim_{x \rightarrow 0} \frac{\sqrt{x+2} - \sqrt{2}}{\sin 3x};$$

$$\text{в) } \lim_{x \rightarrow \frac{\pi}{2}} (1 + \cos 3x)^{\sec x}.$$

11. (201-220) Berilgan funksiyani  $x=x_0$  nuqta atrofida Lagranj shaklidagi qoldiq hadli Teylor formulasi bo'yicha 4-darajali hadgacha yoying.

$$201. f(x) = \sqrt{x}; x_0 = 1$$

$$202. f(x) = \sqrt[3]{1-x}; x_0 = 0$$

$$203. f(x) = \ln x; x_0 = 2$$

$$204. f(x) = \sin^2 x; x_0 = 0$$

$$205. f(x) = \cos^2 x; x_0 = 0$$

$$206. f(x) = x^2 \cdot \ln x; x_0 = 1$$

$$207. f(x) = x^4 - x + 1; x_0 = -2$$

$$208. f(x) = \frac{1}{x}; x_0 = 2$$

$$209. f(x) = \operatorname{sh} x; x_0 = 0$$

$$210. f(x) = \operatorname{ch} x; x_0 = 0$$

$$211. f(x) = \sqrt{1+x}; x_0 = 3$$

$$212. f(x) = \sqrt[3]{x}; x_0 = 8$$



$$213. f(x) = 2^x; x_0 = 0$$

$$214. f(x) = \frac{x}{x-1}; x_0 = 2$$

$$215. f(x) = \sqrt[5]{x}; x_0 = 4$$

$$216. f(x) = \sqrt[3]{x+1}; x_0 = 0$$

$$217. f(x) = x \ln x; x_0 = 1$$

$$218. f(x) = \sin 2x; x_0 = 0$$

$$219. f(x) = \cos 2x; x_0 = 0$$

$$220. f(x) = \sqrt[4]{1+x}; x_0 = 0$$

12. (221-240) Berilgan funksiyani hosila yordamida tekshiring va tekshirish natijalariga ko'ra funksiyaning grafigini chizing.

$$221. 1) y = \frac{y^2 + 4}{x^2};$$

$$2) y = (2x + 3) \cdot e^{-2(x+1)};$$

$$3) y = \sqrt[3]{(2-x)(x^2 - 4x + 1)}.$$

$$222. 1) y = \frac{x^2 - x + 1}{x-1};$$

$$2) y = \frac{e^{2 \cdot (x+1)}}{2 \cdot (x+1)};$$

$$3) y = \sqrt[3]{(x+3)(x^2 + 6x + 6)}.$$

$$223. 1) y = \frac{2}{x^2 + 2x};$$

$$2) y = 3 \cdot \ln \frac{x}{x-3} - 1;$$

$$3) y = \sqrt[3]{(x+2)(x^2 + 4x + 1)}.$$

$$224. 1) y = \frac{4x^2}{3+x^2};$$

$$2) y = (3-x) \cdot e^{x-2};$$

$$3) y = \sqrt[3]{(x+1)(x^2 + 2x - 2)}.$$

$$225. 1) y = \frac{12}{9+x^2};$$

$$3) y = \sqrt[3]{(x-1)(x^2-2x-2)}.$$

$$2) y = \frac{e^{2-x}}{2-x};$$

$$226. 1) y = \frac{x^2-3x+3}{x-1};$$

$$3) y = \sqrt[3]{(x-3)(x^2-6x+6)}.$$

$$2) y = \ln \frac{x}{x+2} + 1;$$

$$227. 1) y = \frac{4-x^3}{x^3};$$

$$3) y = \sqrt[3]{(x^2-4x+3)^2}.$$

$$2) y = (x-2) \cdot e^{3-x};$$

$$228. 1) y = \frac{x^2-4x+1}{x-4};$$

$$3) y = \sqrt[3]{x^2(x+2)^2}.$$

$$2) y = \frac{e^2(x-1)}{2(x-1)};$$

$$229. 1) y = \frac{2x^3+1}{x^2};$$

$$3) y = \sqrt[3]{x^2(x-2)^2}.$$

$$2) y = 3 - 3 \ln \frac{x}{x+4};$$

$$230. 1) y = \frac{(x-1)^2}{x^2};$$

$$3) y = \sqrt[3]{(x^2-2x-1)^2}.$$

$$2) y = -(2x+1)e^{2(x+1)};$$

$$231. 1) y = \frac{x^2}{(x-1)^2};$$

$$3) y = \sqrt[3]{x^2(x+4)^2}.$$

$$2) y = \frac{e^2(x+2)}{2(x+2)};$$

$$232. 1)y = \left(1 + \frac{1}{x}\right)^2;$$

$$2)y = \ln \frac{x}{x-2} - 2$$

$$3)y = \sqrt[3]{x^2(x-4)^2}$$

$$233. 1)y = \frac{12-3x^2}{x^2+12}$$

$$2)y = (2x+5) \cdot e^{-2(x+2)};$$

$$3)y = \sqrt[3]{(x+3)x^2}$$

$$234. 1)y = \frac{9+6x-3x^2}{x^2-2x+13};$$

$$2)y = \frac{e^{3-x}}{3-x};$$

$$3)y = \sqrt[3]{(x-1)(x+2)^2}$$

$$235. 1)y = -\frac{8x}{x^2+4}$$

$$2)y = 2 \cdot \ln \frac{x}{x+1} - 1;$$

$$3)y = \sqrt[3]{(x-1)^2} - \sqrt[3]{x^2}$$

$$236. 1)y = \left(\frac{x-1}{x+1}\right)^2;$$

$$2)y = (4-x)e^{x-2};$$

$$3)y = \sqrt[3]{(x+6) \cdot x^2}$$

$$237. 1)y = \frac{9x^4+1}{x^3};$$

$$2)y = -\frac{e^{-2(x+2)}}{2(x+2)};$$

$$3)y = \sqrt[3]{(x-4)(x+2)^2}$$

$$238. 1)y = \frac{4x}{(x+1)^2}$$

$$2)y = 2 \ln \frac{x+3}{x} - 3$$

$$3)y = \sqrt[3]{(x-1)^2} - \sqrt[3]{(x-2)^2}$$

$$239. 1) y = \frac{8(x-1)}{(x+1)^2}$$

$$2) y = (2x-1)e^{2(1-x)}$$

$$3) y = \sqrt[3]{(x+1)(x-2)^2}$$

$$240. 1) y = \frac{1-2x^3}{x^2}$$

$$2) y = -\frac{e^{-(x+2)}}{x+2}$$

$$3) y = \sqrt[3]{(x-3)x^2}$$

## 2-§. IKKINCHI YOZMA ISH TOPSHIRIQLARI

### Bir o'zgaruvchili funksiyaning integral hisobi

1. (241-260) Quyidagi aniqmas integrallarni hisoblang. Misollarning a) va b) bo'limlarida integrallash natijasini differensiallash orqali tekshiring.

$$241. a) \int e^{\sin^2 x} \cdot \sin 2x dx;$$

$$b) \int \arctg \sqrt{x} dx;$$

$$b) \int \frac{dx}{x^3+8};$$

$$r) \int e^x \ln(1+3e^x) dx.$$

$$242. a) \int e^{\sin^2 x} \cdot \sin 2x dx;$$

$$b) \int \frac{dx}{1+\sqrt[3]{x+1}};$$

$$b) \int \frac{2x^2-3x+1}{x^3+1} dx;$$

$$r) \int \frac{dx}{\sin x + \operatorname{tg} x}.$$

$$243. a) \int \frac{x^3 dx}{\sqrt{1-x^2}};$$

$$b) \int x \cdot 3^x dx;$$

$$b) \int \frac{(3x-7)dx}{x^3+4x^2+4x+16};$$

$$r) \int \frac{dx}{\sqrt{x+3} + \sqrt[3]{(x+3)^2}}.$$

$$244. a) \int \frac{dx}{\cos^2 x (3 \operatorname{tg} x + 1)};$$

$$b) \int \frac{x \cdot \arcsin x}{\sqrt{1-x^2}} dx;$$

$$\text{B) } \int \frac{dx}{x^3 + x^2 + 2x + 2};$$

$$\text{r) } \int \frac{x^2 + \sqrt{1+x}}{\sqrt[3]{1+x}} dx.$$

$$245. \text{ a) } \int \frac{\cos 3x dx}{4 + \sin 3x};$$

$$\text{б) } \int x^2 e^{3x} dx;$$

$$\text{B) } \int \frac{x^2 dx}{x^3 + 5x^2 + 8x + 4};$$

$$\text{r) } \int \frac{\cos x dx}{1 + \cos x}.$$

$$246. \text{ a) } \int \frac{\sin x dx}{\sqrt[3]{\cos^2 x}};$$

$$\text{б) } \int x \arcsin \frac{1}{x} dx;$$

$$\text{B) } \int \frac{(x+3)dx}{x^3 + x^2 - 2x};$$

$$\text{r) } \int \frac{(\sqrt[4]{x} + 1)dx}{(\sqrt{x} + 4)\sqrt{x^3}}.$$

$$247. \text{ a) } \int \frac{(x + \arctg x) dx}{1 + x^2};$$

$$\text{б) } \int x \ln(x^2 + 1) dx;$$

$$\text{B) } \int \frac{(x^2 - 3) dx}{x^4 + 5x^2 + 6};$$

$$\text{r) } \int \frac{\sqrt{x+5} dx}{\sqrt[3]{x+5+1}}.$$

$$248. \text{ a) } \int \frac{\arctg \sqrt{x} dx}{\sqrt{x}(1+x)} dx;$$

$$\text{б) } \int x \sin x \cos x dx;$$

$$\text{B) } \int \frac{x^2 dx}{x^4 - 81};$$

$$\text{r) } \int \frac{dx}{3 \cos x + 4 \sin x}.$$

$$249. \text{ a) } \int \frac{3 \sin x dx}{\sqrt[3]{3 + 2 \cos x}};$$

$$\text{б) } \int x^2 \sin 4x dx;$$

$$\text{B) } \int \frac{(x^2 - x + 1) dx}{x^4 + 2x^2 - 3};$$

$$\text{r) } \int \frac{(\sqrt{x} - 1)(\sqrt[6]{x} + 1) dx}{\sqrt[3]{x^2}}.$$

$$250. \text{ a) } \int \frac{\sqrt[3]{4 + \ln x}}{x} dx;$$

$$\text{б) } \int x \ln^2 x dx;$$

$$b) \int \frac{(x^3 - 6) dx}{x^4 + 6x^2 + 8};$$

$$r) \int \frac{dx}{2 \sin x + \cos x + 2};$$

$$251. a) \int \frac{x^3 dx}{\sqrt[4]{x^3 + 1}} dx;$$

$$b) \int e^{2x} x^3 dx;$$

$$b) \int \frac{dx}{(x+1)^2(x^2+1)};$$

$$r) \int \sqrt{\frac{1-x}{1+x}} dx.$$

$$252. a) \int \frac{dx}{\sqrt{x+1} + 1};$$

$$b) \int x^2 \cos x dx;$$

$$b) \int \frac{x^3 + x^2 + 2}{x(x^2 - 1)^2} dx;$$

$$r) \int \frac{dx}{(x-1)\sqrt[3]{x}}.$$

$$253. a) \int \frac{e^x dx}{e^{2x} + 4};$$

$$b) \int \frac{\cos^3 x}{\sin^4 x} dx;$$

$$b) \int \frac{x + \sqrt[3]{x^2} + \sqrt[6]{x}}{x(1 + \sqrt[3]{x})} dx;$$

$$r) \int \sin 2x \cos x dx$$

$$254. a) \int \frac{(2x-3)^{\frac{1}{2}}}{(2x-3)^{\frac{1}{3}}} dx;$$

$$b) \int \sin 5x \cdot \cos 7x dx;$$

$$b) \int \frac{dx}{\sqrt{x^2 - 4x + 6}};$$

$$r) \int \arctg(\sqrt{4x-1}) dx.$$

$$255. a) \int (3x+4)e^{3x} dx;$$

$$b) \int \frac{x^3 - 17}{x^2 - 4x + 3} dx;$$

$$b) \int \frac{2}{(2-x)\sqrt{\frac{2-x}{2+x}}} dx;$$

$$r) \int \sin x \cdot \cos^3 x dx.$$

$$256. a) \int (4x-2) \cos 2x dx;$$

$$b) \int \frac{2x^3 + 5}{x^2 - x - 2} dx;$$

$$B) \int \frac{dx}{\sqrt{(x-1)^3(x+2)^5}};$$

$$r) \int \sin 2x \cdot \cos^4 x dx.$$

$$257. a) \int (4-16x) \sin 4x dx;$$

$$b) \int \frac{2x^3-1}{x^2+x-6} dx;$$

$$B) \int \frac{\sqrt{x+1}+2}{(x+1)^2-\sqrt{x+1}} dx;$$

$$r) \int \sin 2x \cdot \cos^3 x dx.$$

$$258. a) \int \ln(x^2+1);$$

$$b) \int \frac{3x^3+25}{x^2+3x+2} dx;$$

$$B) \int \frac{dx}{\sqrt{x+\sqrt[3]{x}}};$$

$$r) \int \frac{dx}{5+4 \sin x};$$

$$259. a) \int (5x-2)e^{3x} dx;$$

$$b) \int \frac{(x^3+2x^2+3)}{(x-1)(x-2)(x-3)} dx;$$

$$B) \int \sqrt{(x-1)(x-2)} dx;$$

$$r) \int \sin^3 x \cdot \cos 2x dx.$$

$$260. a) \int (1-6x)e^{2x} dx;$$

$$b) \int \frac{3x^3+2x^2+1}{(x^2-4)(x+1)} dx;$$

$$B) \int \frac{dx}{\sqrt[3]{(x-1)(x+1)^2}};$$

$$r) \int \sin 4x \cdot \cos 5x dx.$$

2. (261-280) Xosmas integralni hisoblang yoki uning uzoqlashuvchiligini ko'rsating:

$$261. \int_0^{\infty} x e^{-x^2} dx$$

$$264. \int_0^1 \frac{x^2 dx}{\sqrt{1-x^3}}$$

$$262. \int_{-\infty}^3 \frac{xdx}{(x^2+1)^2}$$

$$265. \int_1^2 \frac{dx}{(x-1)^2}$$

$$263. \int_{-1}^{\infty} \frac{dx}{x^2+x+1}$$

$$266. \int_{-3}^2 \frac{dx}{(x+3)^2}$$

267. 
$$\int_2^{\infty} \frac{dx}{x \ln x}$$

268. 
$$\int_0^3 \frac{dx}{(x-2)^2}$$

269. 
$$\int_0^4 \frac{dx}{\sqrt[3]{(x-3)^2}}$$

270. 
$$\int_{-\infty}^{\infty} \frac{dx}{x^2 + 4x + 5}$$

271. 
$$\int_{-\infty}^{\infty} \frac{dx}{x^2 + 1}$$

272. 
$$\int_0^1 \frac{dx}{x}$$

273. 
$$\int_{-1}^2 \frac{dx}{\sqrt[3]{(x-1)^2}}$$

274. 
$$\int_0^2 \frac{dx}{(x-1)^2}$$

275. 
$$\int_0^1 \ln x dx$$

276. 
$$\int_2^6 \frac{dx}{\sqrt[3]{(4-x)^2}}$$

277. 
$$\int_{-\infty}^0 xe^x dx$$

278. 
$$\int_0^{\infty} e^{-x} dx$$

279. 
$$\int_{-\infty}^{\infty} \frac{dx}{x^2 + 2x + 2}$$

280. 
$$\int_{-\infty}^1 e^t dt$$

3.(281-300) Aniq integral tatbig'iga oid masalalarni yeching:

281.  $y=3x^2+1$  parabola va  $y=3x+7$  to'g'ri chiziq bilan chegaralangan yassi figura yuzini hisoblang.

282.  $x=a(t-\sin t)$ ;  $y=a(1-\cos t)$  ( $0 \leq t \leq 2\pi$ ) sikloidaning bir arkasi va  $Ox$  koordinata o'qi bilan chegaralangan yassi figura yuzini hisoblang.

283.  $r=3(1+\cos\varphi)$  kardioida bilan chegaralangan yassi figura yuzini hisoblang.

284.  $r=\sin 2\varphi$  to'rt yaproqli atirgul bilan chegaralangan yassi figura yuzini hisoblang.



285.  $y=4-x^2$  va  $y=x^2-2x$  parabolalar bilan chegaralangan yassi figura yuzini hisoblang.

286.  $6x=y^3-16y$  va  $24x=y^3-16y$  kubik parabolalar bilan chegaralangan yassi figura yuzini hisoblang.

287.  $x=a\cos t$ ,  $y=a\sin t$  ellips bilan chegaralangan yassi figura yuzini hisoblang.

288.  $r=a\cos 3\varphi$  uch yaproqli atirgul bilan chegaralangan yassi figura yuzini hisoblang.

289.  $y^2=2px$  va  $x=a$  chiziqlar bilan chegaralangan figurani  $Ox$  o'qi atrofida aylantirishdan hosil bo'lgan jismning hajmini hisoblang.

290.  $2y=x^2$  va  $2x+2y-3=0$  chiziqlar bilan chegaralangan figuraning  $Ox$  o'qi atrofida aylantirishdan hosil bo'lgan jismning hajmini hisoblang.

291.  $y=4-x^2$  va  $y=0$  chiziqlar bilan chegaralangan figurani  $x=3$  to'g'ri chiziq atrofida aylantirishdan hosil bo'lgan jismning hajmini hisoblang.

292.  $y=x^2$  va  $y=\sqrt{x}$  chiziqlar bilan chegaralangan figurani  $Ox$  o'qi atrofida aylantirishdan hosil bo'lgan jismning hajmini hisoblang.

293.  $y=3\sqrt{1-x^2}$ ,  $x=\sqrt{1-y}$  chiziqlar va  $Oy$  o'qi bilan chegaralangan figurani  $Ox$  o'qi atrofida aylantirishdan hosil bo'lgan jismning hajmini hisoblang.

294.  $y=\frac{2}{1+x^2}$  va  $y=x^2$  chiziqlar bilan chegaralangan figurani  $Oy$  o'qi atrofida aylantirishdan hosil bo'lgan jismning hajmini hisoblang.

295.  $x = a \cos^3 t$ ,  $y = a \sin^3 t$  astroida bilan chegaralangan figurani  $Ox$  o'qi atrofida aylantirishdan hosil bo'lgan jismning hajmini hisoblang.

296.  $y = \sqrt{(x-2)^3}$  yarim kubik parabolaning  $A(2;-1)$  va  $B(5;-8)$  nuqtalar bilan chegaralangan yoyning uzunligini hisoblang.

297.  $r = 3(1 - \cos \varphi)$  kardioidaning uzunligini hisoblang.

298.  $x = 3(t - \sin t)$ ,  $y = 3(1 - \cos t)$  sikloidaning bir arkasining uzunligini hisoblang ( $0 \leq t \leq 2\pi$ ).

299.  $x = a \cos^3 t$ ,  $e = a \sin^3 t$  astroidaning uzunligini hisoblang.

300. Kesishish nuqtalari  $A(1;1)$  va  $B(-1;1)$  nuqtalarda bo'lgan  $y^3 = x^2$  va  $y = \sqrt{2 - x^2}$  egri chiziqlar bilan chegaralangan figuraning perimetrini hisoblang.

### Ko'p o'zgaruvchili funksiyalar

4. (301-320)  $z = f(x; y)$  funksiya berilgan.

$F\left(x; y; z; \frac{\partial z}{\partial x}; \frac{\partial z}{\partial y}; \frac{\partial^2 z}{\partial x \partial y}; \frac{\partial^2 z}{\partial x^2}; \frac{\partial^2 z}{\partial y^2}\right) = 0$  ayniyatni isbotlang.

$$301. z = \frac{y}{(x^2 - y^2)}; F = \frac{1}{x} \frac{\partial z}{\partial x} + \frac{1}{y} \frac{\partial z}{\partial y} - \frac{z}{y^2};$$

$$302. z = \frac{y^2}{3x} + \arcsin(xy); F = x \frac{\partial z}{\partial x} - xy \frac{\partial z}{\partial y} + y^2;$$

$$303. z = \ln(x^2 + y^2 + 2x + 1); F = \frac{\partial^2 z}{\partial x^2} + \frac{\partial^2 z}{\partial y^2};$$

$$304. z = \frac{y}{(x^2 - y^2)}; F = \frac{1}{x} \frac{\partial z}{\partial x} + \frac{1}{y} \frac{\partial z}{\partial y} - \frac{z}{y^2};$$

$$305. z = \ln(x + e^{-y}); F = \frac{\partial z}{\partial x} \cdot \frac{\partial^2 z}{\partial x \partial y} - \frac{\partial z}{\partial y} \cdot \frac{\partial^2 z}{\partial x^2};$$

$$306. z = \frac{x}{y}; F = x \frac{\partial^2 z}{\partial x \partial y} - \frac{\partial z}{\partial y};$$

$$307. z = x^y; F = \frac{\partial^2 z}{\partial x \partial y} - (1 + y \ln x) \frac{\partial z}{\partial x};$$

$$308. z = x \cdot e^{\frac{y}{x}}; F = x^2 \frac{\partial^2 z}{\partial x^2} + 2xy \frac{\partial^2 z}{\partial x \partial y} + y^2 \frac{\partial^2 z}{\partial y^2};$$

$$309. z = \sin(x + ay); F = \frac{\partial^2 z}{\partial y^2} - a^2 \frac{\partial^2 z}{\partial x^2};$$

$$310. z = \cos y + (y - x) \sin y; F = (x - y) \frac{\partial^2 z}{\partial x \partial y} - \frac{\partial z}{\partial y};$$

$$311. z = x \cdot \ln\left(\frac{y}{x}\right); F = x \frac{\partial z}{\partial x} + y \frac{\partial z}{\partial y} - z$$

$$312. z = 4y(x^2 - y^2); F = \frac{1}{x} \frac{\partial z}{\partial x} + \frac{1}{y} \frac{\partial z}{\partial y} - \frac{z}{y^2}$$

$$313. z = 2 \cos^2\left(y - \frac{x}{2}\right); F = 2 \frac{\partial^2 z}{\partial x^2} + \frac{\partial^2 z}{\partial x \partial y}$$

$$314. z = xy + 3y; F = x \frac{\partial z}{\partial x} + y \frac{\partial z}{\partial y} - xy - z$$

$$315. z = 8y - x^2 - y^2; F = x \frac{\partial z}{\partial x} + y \frac{\partial z}{\partial y} - z + x^2 + y^2$$

$$316. z = 3x(x + y) + 4y(x + y); F = \frac{\partial^2 z}{\partial x^2} - 2 \frac{\partial^2 z}{\partial x \partial y} + \frac{\partial^2 z}{\partial y^2}$$

$$317. z = xy + 7y; F = x \frac{\partial z}{\partial x} + y \frac{\partial z}{\partial y} - xy - z$$

$$318. z = 2x^2 + 7xy + 5y^2; F = \frac{\partial^2 z}{\partial x^2} - 2 \frac{\partial^2 z}{\partial x \partial y} + \frac{\partial^2 z}{\partial y^2}$$

$$319. z = 3y e^{\left( ye^{\frac{x^2}{y^2}} \right)}; F = (x^2 - y^2) \frac{\partial z}{\partial x} + xy \frac{\partial z}{\partial y} - xyz$$

$$320. z = 5x^2 y + \frac{1}{xy^2}; F = x^2 \frac{\partial^2 z}{\partial x^2} + 2xy \frac{\partial^2 z}{\partial x \partial y} + y^2 \frac{\partial^2 z}{\partial y^2} + x \frac{\partial z}{\partial x} + y \frac{\partial z}{\partial y} - 9z$$

5.(321-340)  $z=f(x;y)$  funksiya,  $A(x_0,y_0)$  nuqta va  $\vec{a}$  vektorlar berilgan.

*Toping:*

a)  $z=f(x;y)$  funksiyaning  $A$  nuqtadagi gradientini.

b)  $\vec{a}$  vektor yo'nalishi bo'yicha  $z=f(x;y)$  funksiyaning  $A$  nuqtadagi xosilasini.

$$321. z = x^2 + xy + y^2; A(-1;1), \vec{a}(2;-1)$$

$$322. z = 2x^2 + 3xy + y^2; A(2;1), \vec{a}(3;-4)$$

$$323. z = \ln(5x^2 + 3y^2); A(1;1), \vec{a}(3;2)$$

$$324. z = \ln(5x^2 + 4y^2); A(1;1), \vec{a}(2;-1)$$

$$325. z = 3x^2 + 6xy; A(2;1), \vec{a}(1;2)$$

$$326. z = \arctg(xy^2); A(2;3), \vec{a}(4;-3)$$

$$327. z = \arcsin\left(\frac{x^2}{y}\right); A(1;2), \vec{a}(5;-12)$$

$$328. z = \ln(3x^2 + 4y^2); A(1;3), \vec{a}(2;-1)$$

$$329. z = 3x^4 + 2x^2 y^3; A(-1;2), \vec{a}(4;-3)$$

$$330. z = 3x^2 y^2 + 5xy^2; A(1;1), \vec{a}(2;1)$$

331.  $z = xy + 2y^2 - 2x; A(1;2), \bar{a}(-2;1)$

332.  $z = 2xy + 3y^2 - 5x; A(1;1), \bar{a}(3;-2)$

333.  $z = x^2 - y^2 + 5x + 4y; A(3;2), \bar{a}(1;1)$

334.  $z = 3x^2 + 2y^2 - xy; A(-1;3), \bar{a}(1;2)$

335.  $z = \arcsin\left(\frac{y}{x^2}\right); A(3;2), \bar{a}(-3;4)$

336.  $z = x^2 + y^2 + 2x + y - 1; A(2;4), \bar{a}(3;-4)$

337.  $z = x^2 - y^2 + 6x + 3y; A(2;3), \bar{a}(4;-3)$

338.  $z = \arctg(x^2y); A(3;2), \bar{a}(-3;4)$

339.  $z = x^2 + 3xy - 6y; A(4;1), \bar{a}(2;-1)$

340.  $z = 3x^2 - xy + x + y; A(1;3), \bar{a}(2;-1)$

**Oddiy differensial tenglamalar**

6.(341-360) Berilgan differensial tenglamalarning umumiy yechimini toping.

341. a)  $(x^2 - y^2)y' = 2xy;$  b)  $(1 - x^2)y'' = xy'$

342. a)  $(1 + x^2)y' - 2xy = (1 + x^2)^2;$  b)  $2yy'' + (y')^2 + (y')^4 = 0$

343. a)  $xy' = y \ln\left(\frac{y}{x}\right);$  b)  $y'' + y'tgx = \sin 2x$

344. a)  $xy' + y = 3;$  b)  $y'' + \frac{y'}{x} = x^2$

345. a)  $xy' + xe^{y/x} = y;$  b)  $1 + (y')^2 + yy'' = 0$

346. a)  $y' \cos x = (y + 1) \sin x;$  b)  $(1 + y)y'' - 5(y')^2 = 0$

347. a)  $xy' - y = \sqrt{x^2 + y^2};$  b)  $xy'' + 2y' = x^3$

348. a)  $x^2y' - 2xy = 3;$  b)  $y'' \operatorname{tgy} = 2(y')^2$

349. a)  $x^2y' + y^2 - 2xy = 0$ ;      b)  $3yy'' + (y')^2 = 0$   
 350. a)  $xy' + y = x + 1$ ;      b)  $y'' - 2y'tgx = \sin x$   
 351. a)  $(1 + e^x)y' = ye^x$ ;      b)  $y'' = 128y^3$   
 352. a)  $y(1 + \ln y) + xy' = 0$ ;      b)  $y'' + 2\sin y \cos^2 y = 0$   
 353. a)  $(1 + e^x)yy' = e^x$ ;      b)  $y''y^3 + 49 = 0$   
 354. a)  $y \ln y + xy' = 0$ ;      b)  $y'' = 2y^3$   
 355. a)  $\sqrt{1 - x^2}y' + xy^2 + x = 0$ ;      b)  $y''y^3 + 4 = 0$   
 356. a)  $(3 + e^x)yy' = e^x$ ;      b)  $y''y^3 = 4(y'' - 1)$   
 357. a)  $x - yy' = yx^2y' - xy^2$ ;      b)  $4y^3y'' = y'' - 16$   
 358. a)  $4x - 3yy' = 3x^2yy' - 2xy^2$ ;      b)  $x^2y'' - 2xy' + 2y = 0$   
 359. a)  $\sqrt{4 - x^2}y' + xy^2 + x = 0$ ;      b)  $yy'' - (y')^2 + (y')^3 = 0$   
 360. a)  $(e^x + 8)y' - ye^x = 0$ ;      b)  $y'' + \operatorname{tg}xy' = \sin 2x$

7.(361-380) Berilgan tenglamaning to'la differensial tenglama ekanligini aniqlab, uning umumiy yechimini toping:

361.  $3x^2e^y dx + (x^3e^y - 1)dy = 0$ .

362.  $\left(3x^2 + \frac{2}{y} \cos \frac{2x}{y}\right) dx = \frac{2x}{y^2} \cdot \cos \frac{2x}{y} dy$ .

363.  $(3x^2 + 4y^2) dx + (8xy + e^y) dy = 0$ .

364.  $\left(2x - 1 - \frac{y}{x^2}\right) dx - \left(2y - \frac{1}{x}\right) dy$ .

365.  $(y^2 + y \cdot \sec^2 x) dx + (2xy + \operatorname{tg}x) dy = 0$ .

366.  $(3x^2y + 2y + 3) dx + (x^3 + 2x + 3y^2) dy = 0$ .

$$367. \left( \frac{x}{\sqrt{x^2 + y^2}} + \frac{1}{x} + \frac{1}{y} \right) dx + \left( \frac{y}{\sqrt{x^2 + y^2}} + \frac{1}{y} - \frac{x}{y^2} \right) dy = 0.$$

$$368. [\sin 2x - 2 \cos(x + y)] dx - 2 \cos(x + y) dy = 0.$$

$$369. (x^2 + y^2 + 2x) dx + 2xy dy = 0.$$

$$370. (x + y) dx + (e^y + x + 2y) dy = 0.$$

$$371. xy^2 dx + y(x^2 + y^2) dy = 0.$$

$$372. \left( \frac{x}{\sqrt{x^2 + y^2}} + y \right) dx + \left( x + \frac{y}{\sqrt{x^2 + y^2}} \right) dy = 0.$$

$$373. \frac{1 + xy}{x^2 y} dx + \frac{1 - xy}{xy^2} dy = 0.$$

$$374. \frac{dx}{y} - \frac{x + y^2}{y^2} dy = 0.$$

$$375. \frac{y}{x^2} dx - \frac{xy + 1}{x} dy = 0.$$

$$376. \left( xe^x + \frac{y}{x^2} \right) dx - \frac{dy}{x} = 0.$$

$$377. \left( 10xy - \frac{1}{\sin y} \right) dx + \left( 5x^2 + \frac{x \cos y}{\sin^2 y} - y^2 \sin y^3 \right) dy = 0.$$

$$378. \left( \frac{y}{x^2 + y^2} + e^x \right) dx - \frac{x}{x^2 + y^2} dy = 0.$$

$$379. e^y dx + (\cos y + xe^y) dy = 0.$$

$$380. (y^3 + \cos x) dx + (3xy^2 + e^y) dy = 0.$$

8. (381-400) Masalaning shartiga qarab differensial tenglamaning xususiy yoki umumiy yechimini toping:

$$381. 4y^3y'' = y^4 - 16, y(0) = 2\sqrt{2}; y'(0) = \frac{1}{\sqrt{2}}.$$

$$382. y'' = 128y; y(0) = 1; y'(0) = 8.$$

$$383. y''y^3 + 64 = 0; y(0) = 4; y'(0) = 2.$$

$$384. y'' = 32\sin^3 y \cos y; y(1) = \frac{\pi}{2}; y'(1) = 4.$$

$$385. y'' = 2y^3; y(-1) = 1; y'(1) = 1.$$

$$386. x^2y'' + xy' = 1.$$

$$387. \operatorname{tg}x \cdot y''' = 2y''.$$

$$388. (1 + x^2)y'' + 2xy' = x^3.$$

$$389. y'' + \frac{2x}{1+x^2} \cdot y' = 2x.$$

$$390. x^4y'' + x^3y' = 4.$$

$$391. y''' - 36y' = 299(\cos 7x + \sin 7x).$$

$$392. 2xy''' = y''.$$

$$393. xy''' + y'' = 1.$$

$$394. xy''' + 2y'' = 0.$$

$$395. y'' = 32y^3; y(4) = 1; y'(4) = 4.$$

$$396. y''y^3 + 16 = 0; y(1) = 2; y'(1) = 2.$$

$$397. y'' = 2y^3, y(-1) = 1, y'(-1) = 1.$$

$$398. y''y^3 + y = 0; y(0) = -1; y'(0) = -2.$$

$$399. y^3y'' = 4(y^4 - 1); y(0) = \sqrt{2}; y'(0) = \sqrt{2}.$$

$$400. xy''' = 2.$$



9.(401-420)  $y''+py'+qy=f(x)$  ko'rinishdagi tenglamaning  $y_0=y(x_0)$ ,  $y_0'=y'(x_0)$  boshlang'ich shartlarni qanoatlantiruvchi xususiy yechimini toping:

401.  $y''+4y-12y=8\sin 2x; y(0)=0; y'(0)=0.$

402.  $y''-6y'+9y=x^2-x+3; y(0)=\frac{4}{3}; y'(0)=\frac{1}{27}.$

403.  $y''+4y=e^{-2x}; y(0)=0; y'(0)=0.$

404.  $y''-2y'+5y=xe^{2x}; y(0)=1; y'(0)=0.$

405.  $y''+5y'+6y=12\cos 2x; y(0)=1; y'(0)=3.$

406.  $y''-5y'+6y=(12x-7)\cdot e^{-x}; y(0)=0; y'(0)=0.$

407.  $y''-4y'+13y=26x+5; y(0)=1; y'(0)=0.$

408.  $y''-4y'=6x^2+1; y(0)=2; y'(0)=3.$

409.  $y''-2y'+y=16e^x; y(0)=1; y'(0)=2.$

410.  $y''+6y'+9y=10e^{-3x}; y(0)=3; y'(0)=2.$

411.  $y''+6y'+5y=25x^2-2; y(0)=1; y'(0)=0.$

412.  $y''-6y'-9y=3x-8e^x; y(0)=0; y'(0)=0.$

413.  $y''-2y'+10y=37\cos 3x; y(0)=0; y'(0)=0.$

414.  $y''-4y'+4y=e^{2x}\sin 5x; y(0)=1; y'(0)=0.$

415.  $y''-4y'+8y=e^x(2\cos x-\sin x); y(0)=1; y'(0)=2.$

416.  $y''+2y'+y=e^x\cdot\cos 2x; y(0)=1; y'(0)=0.$

417.  $y''+2y'=4e^x(\sin x+\cos x); y(0)=0; y'(0)=0.$

418.  $y''+2y'+5y=-\sin 2x; y(0)=1; y'(0)=0.$

419.  $y''+y=2\cos 5x+3\sin 5x; y(0)=2; y'(0)=1.$

420.  $y''+2y'+5y=-\cos x; y(0)=1; y'(0)=0.$

10.(421-440) O'zgarmas koeffitsientli chiziqli differensial tenglamalar sistemasi berilgan.

**Topilsin:**

- a) xarakteristik tenglama yordamida sistemaning umumiy yechimini;  
b) berilgan sistemani matritsa usulida yechimini.

$$421. \begin{cases} \frac{dx}{dt} = 4x + 6y \\ \frac{dy}{dt} = 4x + 2y \end{cases}$$

$$427. \begin{cases} \frac{dx}{dt} = -4x - 6y \\ \frac{dy}{dt} = -4x - 2y \end{cases}$$

$$422. \begin{cases} \frac{dx}{dt} = -5x - 4y \\ \frac{dy}{dt} = -2x - 3y \end{cases}$$

$$428. \begin{cases} \frac{dx}{dt} = -5x - 8y \\ \frac{dy}{dt} = -3x - 3y \end{cases}$$

$$423. \begin{cases} \frac{dx}{dt} = 3x + y \\ \frac{dy}{dt} = 8x + y \end{cases}$$

$$429. \begin{cases} \frac{dx}{dt} = -x - 5y \\ \frac{dy}{dt} = -7x - 3y \end{cases}$$

$$424. \begin{cases} \frac{dx}{dt} = 6x + 3y \\ \frac{dy}{dt} = -8x - 5y \end{cases}$$

$$430. \begin{cases} \frac{dx}{dt} = -7x + 5y \\ \frac{dy}{dt} = 4x - 8y \end{cases}$$

$$425. \begin{cases} \frac{dx}{dt} = -x + 5y \\ \frac{dy}{dt} = x + 3y \end{cases}$$

$$431. \begin{cases} \frac{dx}{dt} = 5x - y \\ \frac{dy}{dt} = x + 3y \end{cases}$$

$$426. \begin{cases} \frac{dx}{dt} = 3x - 2y \\ \frac{dy}{dt} = 2x + 8y \end{cases}$$

$$432. \begin{cases} \frac{dx}{dt} = 8x - y \\ \frac{dy}{dt} = x + y \end{cases}$$

$$433. \begin{cases} \frac{dx}{dt} = x - 4y \\ \frac{dy}{dt} = x + y \end{cases}$$

$$437. \begin{cases} \frac{dx}{dt} = -7x + y \\ \frac{dy}{dt} = -2x - 5y \end{cases}$$

$$434. \begin{cases} \frac{dx}{dt} = 3x + y \\ \frac{dy}{dt} = -4x - y \end{cases}$$

$$438. \begin{cases} \frac{dx}{dt} = x + y \\ \frac{dy}{dt} = -2x + 3y \end{cases}$$

$$435. \begin{cases} \frac{dx}{dt} = x - 2y \\ \frac{dy}{dt} = x - y \end{cases}$$

$$439. \begin{cases} \frac{dx}{dt} = 2x - y \\ \frac{dy}{dt} = 4x + 6y \end{cases}$$

$$436. \begin{cases} \frac{dx}{dt} = 12x - 5y \\ \frac{dy}{dt} = 5x + 12y \end{cases}$$

$$440. \begin{cases} \frac{dx}{dt} = x + 3y \\ \frac{dy}{dt} = -x + 5y \end{cases}$$

### 3-§. UCHINCHI YOZMA ISH TOPSHIRIQLARI

#### Sonli va funksional qatorlar

1.(441-460) Berilgan  $\sum_{n=1}^{\infty} u_n$  sonli qatorni yaqinlashishga tekshiring:

$$441. u_n = \frac{n+3}{n^3-2}$$

$$443. u_n = \frac{e^{-\sqrt{n}}}{\sqrt{n}}$$

$$442. u_n = \frac{2n}{n^2+1}$$

$$444. u_n = \frac{2n}{n^4-9}$$

$$445. u_n = \frac{1}{(2n+1)^2 - 1}$$

$$446. u_n = \frac{n^5}{2n}$$

$$447. u_n = \frac{3^n}{(2n)!}$$

$$448. u_n = \frac{3^{2n+1}}{2^{3n-1}}$$

$$449. u_n = \frac{n^3}{e^n}$$

$$450. u_n = \frac{n!}{5^n}$$

$$451. u_n = \frac{1}{(n+1)[\ln(n+1)]^2 7^{3n}}$$

$$452. u_n = \frac{1}{(2n-5)!}$$

$$453. u_n = \frac{2n+1}{\sqrt{n} \cdot 2^n}$$

$$454. u_n = \frac{2n-3}{n(n+1)}$$

$$455. u_n = \frac{n^2}{(3n)!}$$

$$456. u_n = \frac{n+3}{n^3 - 2}$$

$$457. u_n = \frac{1}{(n+1)\ln(n+1)}$$

$$458. u_n = \frac{2n-1}{2^n}$$

$$459. u_n = \frac{n^{n+1}}{(n+1)!}$$

$$460. u_n = \frac{n^3}{(2n)!}$$

2. (461-480) Berilgan ishoralari almashinuvchi sonli qatorni yaqinlashishga tekshiring:

$$461. \sum_{n=2}^{\infty} (-1)^n \frac{\ln n}{\sqrt[3]{n^7}}$$

462.

$$\sum_{n=1}^{\infty} (-1)^n \frac{1}{\sqrt[3]{n^4} + \sqrt[4]{n^3}}$$

$$463. \sum_{n=2}^{\infty} \frac{(-1)^n}{\sqrt[n]{n + \ln n}}$$

$$464. \sum_{n=1}^{\infty} \frac{(-3)^n}{(2n+1)^n}$$

$$465. \sum_{n=1}^{\infty} (-1)^n \frac{\sqrt[3]{n} + 2}{\sqrt[4]{n} + \sqrt{n}}$$

$$466. \sum_{n=1}^{\infty} \frac{(-1)^n}{n\sqrt[3]{1 + \ln n}}$$

$$467. \sum_{n=1}^{\infty} (-1)^n \ln \frac{3n+2}{2n+3}$$

$$468. \sum_{n=1}^{\infty} \frac{(-1)^n}{n \ln(n+1)}$$

469.

$$\sum_{n=1}^{\infty} \frac{(-1)^n}{\sqrt{n}(e^{\sqrt{n}} + e^{-\sqrt{n}})}$$

$$470. \sum_{n=1}^{\infty} (-1)^n \operatorname{tg} \frac{1}{n}$$

$$471. \sum_{n=1}^{\infty} (-1)^n \frac{3^n}{(3n-2)!}$$

$$472. \sum_{n=1}^{\infty} (-1)^n \frac{1}{n \ln 2n}$$

473.

$$\sum_{n=1}^{\infty} (-1)^n \frac{n}{2\sqrt[4]{n^5} + \sqrt[5]{n^4}}$$

$$474. \sum_{n=1}^{\infty} (-1)^n \sin \frac{\pi}{2\sqrt[8]{n^3}}$$

$$475. \sum_{n=2}^{\infty} (-1)^n \frac{1}{n\sqrt{\ln^3 n}}$$

$$476. \sum_{n=2}^{\infty} \frac{(-1)^n}{n^5 \sqrt{\ln n}}$$

$$477. \sum_{n=2}^{\infty} \frac{(-1)^n}{n^3 \sqrt{\ln n}}$$

$$478. \sum_{n=1}^{\infty} \frac{(-1)^n}{\sqrt[5]{n} + \ln n}$$

$$479. \sum_{n=2}^{\infty} \frac{(-1)^n}{n^4 \sqrt{\ln n}}$$

$$480. \sum_{n=1}^{\infty} \frac{(-1)^n \cdot n}{n^2 + \ln n}$$

3.(481-500) Berilgan  $\sum_{n=1}^{\infty} a_n x^n$  darajali qatorning yaqinlashish

sohasini toping:

$$481. a_n = \frac{\sqrt[3]{(n+1)^n}}{n!}$$

$$482. a_n = \frac{(n!)^2}{(2n)!}$$

$$483. a_n = \frac{2n}{n(n+1)}$$

$$484. a_n = n!$$

$$485. a_n = \frac{(2n)!}{n^n}$$

$$486. a_n = \frac{1}{a^n}$$

$$487. a_n = \frac{3^n \cdot n!}{(n+1)^n}$$

$$488. a_n = \frac{1}{n2^n}$$

$$489. a_n = \frac{n}{3^n(n+1)}$$

$$490. a_n = \frac{n}{2^n(n+1)}$$

$$491. a_n = \frac{5n}{\sqrt[n]{n}}$$

$$492. a_n = \frac{n!}{n^n}$$

$$493. a_n = \left(1 + \frac{1}{n}\right)^n$$

$$494. a_n = \frac{(-1)^{n-1}}{n}$$

$$495. a_n = \frac{n+1}{3^n(n+2)}$$

$$496. a_n = \left(\frac{n}{2n+1}\right)^{2n-1}$$

$$497. a_n = \frac{3n}{\sqrt{2^n(3n-1)}}$$

$$498. a_n = \frac{1}{n(n+1)}$$

$$499. a_n = \frac{n+2}{n(n+1)}$$

$$500. a_n = \frac{1}{n \cdot 10^{n-1}}$$

4. (501-520) Differensial tenglamaning berilgan boshlang'ich shartlarni qanoatlantiruvchi yechimining Teylor qatoriga yoyilmasidagi dastlabki to'rtta hadini toping:

$$501. y' = 2x - \ln y + 3, y(3) = 1.$$

$$502. y' = \sin 2x + \cos y, y\left(\frac{\pi}{2}\right) = \pi.$$

$$503. y' = 2 \ln y - xy, y(2) = 1.$$

$$504. y' = x^2 + 2 \ln y, y(-2) = 1.$$

$$505. y' = x - y + 3e^y, y(-5) = 0.$$

$$506. y' = e^y + xy, y(3) = 0.$$

$$507. y' = x - y + \cos 2y, y(-4) = 0.$$

$$508. y' = 2x - \cos y, y(1) = \frac{\pi}{2}.$$

$$509. y' = e^{2y} + 4x, y(-1) = 0.$$

$$510. y' = x^2 + y^3, y(1) = 1.$$

$$511. y' = x^3 - e^{-y}, y(2) = 0.$$

$$512. y' = 2x^2 + y^3 - 5, y(2) = 1.$$

$$513. y' = x^2 + \frac{2}{y} - 5, y(3) = 1.$$

$$514. y' = x^4 - y^4 + 2, y(-1) = 1.$$

$$515. y' = xy - \frac{1}{x} + x, y(-1) = 1.$$

$$516. y' = x^3 + \sin y, y(1) = \frac{\pi}{2}.$$

$$517. y' = x - y + \frac{x}{y}, y(2) = 1.$$

$$518. y' = \sqrt{y} - x, y(1) = 4.$$

$$519. y' = \sin x + \cos y, y\left(\frac{\pi}{2}\right) = \frac{\pi}{2}.$$

$$520. y' = (2x - y)^3, y(2) = 3.$$

5.(521-540) Berilgan  $f(x)$  funksiyani  $(a;b)$  intervalda Fure qatoriga yoyilmasini toping:

521.  $f(x) = x + 1; \quad (-\pi; \pi)$
522.  $f(x) = e^{-x}; \quad (-\pi; \pi)$
523.  $f(x) = x^2 + 1; \quad (-2; 2)$
524.  $f(x) = e^x; \quad (-2; 2)$
525.  $f(x) = \frac{\pi - x}{2}; \quad (-\pi; \pi)$
526.  $f(x) = e^x + 4; \quad (-2; 2)$
527.  $f(x) = 1 + |x|; \quad (-1; 1)$
528.  $f(x) = \begin{cases} 0 & -\pi < x < 0 \\ x & 0 \leq x < \pi; \end{cases} \quad (-\pi; \pi)$
529.  $f(x) = \pi - x; \quad (0; 2\pi)$
530.  $f(x) = |1 - x|; \quad (-2; 2)$
531.  $f(x) = e^x - 1; \quad (0; 2\pi)$
532.  $f(x) = |x|; \quad (-\pi; \pi)$
533.  $f(x) = x^3; \quad (-\pi; \pi)$
534.  $f(x) = x - 1; \quad (-1; 1)$
535.  $f(x) = x^2; \quad (-\pi; \pi)$
536.  $f(x) = x^2; \quad (0; 2\pi)$
537.  $f(x) = \begin{cases} 6, & 0 < x < 2 \\ 3x, & 2 \leq x < 4; \end{cases} \quad (-1; 1)$
538.  $f(x) = \frac{x}{2}; \quad (0; 2\pi)$
539.  $f(x) = x^2; \quad (-1; 1)$
540.  $f(x) = |x| + 2; \quad (-1; 1)$



## Karrali va egri chiziqli integrallar

6. (541-560) Berilgan ikki karrali integralda integrallash tartibini o'zgartiring:

$$541. \int_{-2}^{-1} dy \int_{-\sqrt{2+y}}^0 f(x, y) dx + \int_{-1}^0 dy \int_{-\sqrt{-y}}^0 f(x, y) dx$$

$$542. \int_0^1 dy \int_{-\sqrt{y}}^0 f(x, y) dx + \int_1^{\sqrt{y}} dy \int_{-\sqrt{2-y^2}}^0 f(x, y) dy$$

$$543. \int_0^1 dy \int_0^y f(x, y) dx + \int_1^{\sqrt{2}} dy \int_0^{\sqrt{2-y^2}} f(x, y) dx$$

$$544. \int_0^1 dy \int_0^{\sqrt{y}} f(x, y) dx + \int_1^2 dy \int_0^{\sqrt{2-y}} f(x, y) dx$$

$$545. \int_{-\sqrt{2}}^{-1} dx \int_{-\sqrt{2-x^2}}^0 f(x, y) dy + \int_{-1}^0 dx \int_x^0 f(x, y) dy$$

$$546. \int_0^{\frac{1}{\sqrt{2}}} dy \int_0^{\arcsin y} f(x, y) dx + \int_{\frac{1}{\sqrt{2}}}^1 dy \int_0^{\arccos y} f(x, y) dx$$

$$547. \int_{-2}^{-1} dy \int_0^{\sqrt{2+y}} f(x, y) dx + \int_{-1}^0 dy \int_0^{\sqrt{-y}} f(x, y) dy$$

$$548. \int_0^1 dy \int_{-\sqrt{y}}^0 f(x, y) dx + \int_1^0 dy \int_{-1}^{-\ln y} f(x, y) dx$$

$$549. \int_{-\sqrt{2}}^{-1} dx \int_0^{\sqrt{2-x^2}} f(x, y) dy + \int_{-1}^0 dx \int_0^{x^2} f(x, y) dy$$

$$550. \int_{-2}^{-\sqrt{3}} dx \int_{-\sqrt{4-x^2}}^0 f(x, y) dy + \int_{-\sqrt{3}}^0 dx \int_{\sqrt{4-x^2}-2}^0 f(x, y) dy$$

$$551. \int_0^1 dx \int_{1-x^2}^0 f(x, y) dy + \int_1^e dx \int_{\ln x}^1 f(x, y) dy$$

$$552. \int_0^1 dy \int_0^{\sqrt{y}} f(x, y) dx + \int_1^2 dy \int_0^{2-y} f(x, y) dx$$

$$553. \int_0^{\frac{\pi}{4}} dy \int_0^{\sin y} f(x, y) dx + \int_{\frac{\pi}{4}}^{\frac{\pi}{2}} dy \int_0^{\cos y} f(x, y) dx$$

$$554. \int_{-2}^{-1} dx \int_{-(2+x)}^0 f(x, y) dy + \int_{-1}^0 dx \int_{\sqrt{x}}^0 f(x, y) dy$$

$$555. \int_0^1 dy \int_0^{\sqrt{y}} f(x, y) dx + \int_1^e dy \int_{\ln y}^1 f(x, y) dx$$

$$556. \int_0^1 dy \int_{-\sqrt{y}}^0 f(x, y) dx + \int_1^2 dy \int_{-\sqrt{2-y}}^0 f(x, y) dx$$

$$557. \int_0^1 dy \int_{-y}^0 f(x, y) dx + \int_1^{\sqrt{2}} dy \int_{-\sqrt{2-y^2}}^0 f(x, y) dx$$

$$558. \int_0^1 dy \int_0^{y^2} f(x, y) dx + \int_1^2 dy \int_0^{2-y} f(x, y) dx$$

$$559. \int_0^{\sqrt{3}} dx \int_{\sqrt{4-x^2}-2}^0 f(x, y) dy + \int_{\sqrt{3}}^2 dx \int_{-\sqrt{4-x^2}}^0 f(x, y) dy$$

$$560. \int_{-2}^{-1} dy \int_{-(2+y)}^0 f(x, y) dx + \int_{-1}^0 dy \int_{\sqrt{y}}^0 f(x, y) dx$$

7. (561-580) Berilgan ikki o'lchamli integralni xisoblang:

$$561. \iint_{(D)} (12x^2y^2 + 16x^3y^3) dx dy, (D) x = 1, y = -\sqrt{x}, y = x^2$$

$$562. \iint_{(D)} (9x^2y^2 + 48x^3 + y^3) dx dy, (D) x = 1, y = -x^2, y = \sqrt{x}$$

$$563. \iint_{(D)} (36x^2y^2 - 96x^3y^3) dx dy, (D) x = 1, y = \sqrt[3]{x}, y = -x^3$$

$$564. \iint_{(D)} (18x^2y^2 + 32x^3y^3) dx dy, (D) x = 1, y = x^3, y = -\sqrt[3]{x}$$

$$565. \iint_{(D)} (27x^2y^2 + 48x^3y^3) dx dy, (D) x = 1, y = x^2, y = -\sqrt[3]{x}$$

$$566. \iint_{(D)} (186x^2y^2 + 32x^3y^3) dx dy, (D) x = 1, y = \sqrt[3]{x}, y = -x^2$$

$$567. \iint_{(D)} (18x^2y^2 + 32x^3y^3) dx dy, (D) x = 1, y = x^3, y = -\sqrt[3]{x}$$

$$568. \iint_{(D)} (27x^2y^2 + 48x^3y^3) dx dy, (D) x = 1, y = \sqrt{x}, y = -x^3$$

$$569. \iint_{(D)} (27x^2y^2 + 48x^3y^3) dx dy, (D) x = 1, y = \sqrt[3]{x}, y = -x^3$$

$$570. \iint_{(D)} (12xy + 9x^2y^2) dx dy, (D) x = 1, y = \sqrt{x}, y = -x^2$$

$$571. \iint_{(D)} (8xy + 9x^2y^2) dx dy, (D) x = 1, y = \sqrt[3]{x}, y = -x^3$$

572.  $\iint_{(D)} (24xy + 18x^2y^2) dx dy, (D) \{x = 1, y = x^3, y = -x^3\}$
573.  $\iint_{(D)} (12xy + 27x^2y^2) dx dy, (D) \{x = 1, y = -x^2, y = -\sqrt[3]{x}\}$
574.  $\iint_{(D)} (8x^2y^2 + 18x^2y^2) dx dy, (D) \{x = 1, y = \sqrt[3]{x}, y = -x^2\}$
575.  $\iint_{(D)} \left( \frac{4}{5}xy + \frac{9}{11}x^2y^2 \right) dx dy, (D) \{x = 1, y = x^3, y = -\sqrt{x}\}$
576.  $\iint_{(D)} \left( \frac{4}{3}xy + 9x^2y^2 \right) dx dy, (D) \{x = 1, y = \sqrt{x}, y = -x^3\}$
577.  $\iint_{(D)} (24xy - 48x^3y^3) dx dy, (D) \{x = 1, y = x^2, y = -\sqrt{x}\}$
578.  $\iint_{(D)} (6xy + 24x^3y^3) dx dy, (D) \{x = 1, y = \sqrt{x}, y = -x^2\}$
579.  $\iint_{(D)} (4xy + 16x^3y^3) dx dy, (D) \{x = 1, y = \sqrt[3]{x}, y = -x^3\}$
580.  $\iint_{(D)} (4xy + 16x^3y^3) dx dy, (D) \{x = 1, y = -\sqrt[3]{x}, y = x^3\}$

8. (581-600) Tenglamasi dekart koordinatlarida berilgan egri chiziq bilan chegaralangan yassi figuraning yuzini ikki o'lichamli integral yordamida qutb koordinatlar sistemasiga o'tib hisoblang:

581.  $(x^2 + y^2)^3 = a^2x^2y^2$
582.  $(x^2 + y^2)^2 = a^2(4x^2 + y^2)$
583.  $(x^2 + y^2)^3 = a^2x^2(4x^2 + 3y^2)$
584.  $(x^2 + y^2)^2 = a^2(3x^2 + 2y^2)$
585.  $x^4 = a^2(3x^2 - y^2)$
586.  $x^6 = a^2(x^4 - y^4)$
587.  $x^4 = a^2(x^2 - 3y^2)$
588.  $y^6 = a^2(y^4 - x^4)$
589.  $(x^2 + y^2)^2 = a^2(2x^2 + 3y^2)$
590.  $y^6 = a^2(x^2 + y^2)(3y^2 - x^2)$

591.  $(x^2 + y^2)^2 = 2y^3$

597.  $x^3 + y^3 = 16xy$

592.  $(x^2 + y^2)^2 = a^2(x^4 + y^4)$

598.  $y = 2 - x, y^2 = 4x + 4$

593.  $(x^2 + y^2)^2 = a^2(x^2 - y^2) (x > 0)$

599.  $y + x = 0, x = y^2 - 2y = 0$

594.  $(y - x)^2 = 1 - x^2$

600.  $(x^2 + y^2)^2 = 2a^2xy$

595.  $(3x^2 + y^2)^2 = 3x^2y$

596.  $(x^2 + y^2)^2 = 64xy$

9. (601-620) Berilgan sirtlar bilan chegaralangan jismning hajmini, uch o'lchamli integral yordamida hisoblang. Jismning shaklini va uning XOY tekisligiga proektsiyasini chizing:

601.  $z = 0, z = x, y = 0, y = 4, x = \sqrt{25 - y^2}$

602.  $z = 0, z = 9 - y^2, x^2 + y^2 = 9$

603.  $z = 0, z = 4 - x - y, x^2 + y^2 = 4$

604.  $z = 0, z = y^2, x^2 + y^2 = 9$

605.  $z = 0, z + y = 2, x^2 + y^2 = 4$

606.  $z = 0, 4z = y^2; 2x - y = 0, x + y = 9$

607.  $z = 0, x^2 + y^2 = z, x^2 + y^2 = 4$

608.  $z = 0, z = 1 - y^2, x = y^2; x = 2y^2 + 1$

609.  $z = 0, z = 1 - x^2, y = 0, y = 3 - x$

610.  $z = 0, z = 4 \cdot \sqrt{y}, x = 0, x + y = 4$

611.  $z = 0, z = 4 - x - y, x = 3, y = 2, x = 0, y = 0$

612.  $z = 0, x + y + z = 1, x = 0, y = 0$

613.  $z = 0, z + x = 3, y = 2, x = 0, y = 0$

614.  $z = 0, z = 3, y = 0, x + y = 2, x = 0$

615.  $z = 0, z = 1, 4z^2 = x^2 + y^2, y = 0, x = 0$

$$616. z = 0, z = 3, y = 0, y = 1, x + y = 1, x + y = 2$$

$$617. z = 0, x + 2z = 3, y = 1, y = 3, x = 0$$

$$618. z = 0, x^2 + y^2 + z^2 = 4, x = \frac{1}{2}(x^2 + y^2)$$

$$619. z = 0, z = x^2 + y^2, x + y = 1, y = 0, x = 0$$

$$620. z = 0, z^2 = xy, y = 5, y = 5, x = 5$$

10. (621-640) Egri chiziqli integrallarni hisoblang:

621.  $L : x=5\cos t, y=5\sin t$ , aylana bo'ylab  $A(5;0)$  nuqtadan  $B(0;5)$  nuqttagacha soat strelkasiga teskari yo'nalishda berilgan  $\int_L (x^2 - y)dx - (x - y^2)dy$  egri chiziqli integralni hisoblang.

622.  $L=OAB$  siniq chiziq bo'ylab berilgan  $\int_L (x+y)dx - (x-y)dy$  egri chiziqli integralni hisoblang. Bunda,  $O(0;0), A(2;0), B(4;5)$ . Chizmasini chizing.

623.  $L = ABC$  uchburchak tomonlari bo'ylab soat strelkasiga teskari yo'nalishda berilgan  $\oint \frac{ydx - xdy}{x^2 + y^2}$  egri chiziqli integralni hisoblang. Bunda,  $A(1;0), B(1;1), C(0;1)$ . Chizmasini chizing.

624.  $L : y=x^2$  parabolaning  $A(-1;1)$  nuqtadan  $B(1;1)$  nuqttagacha bo'lgan yoyi bo'ylab berilgan  $\int_L (x^2 - 2xy)dx + (y^2 - 2xy)dy$  egri chiziqli integralni hisoblang. Chizmasini chizing.

625.  $L : x=3\cos t, y=2\sin t$  ellipsning  $OX$  o'qidan yuqori qismi bo'ylab,  $t$ -parametr o'sishi yo'nalishida berilgan  $\int_L (x^2 y - 3x)dx + (y^2 x + 2y)dy$  egri chiziqli integralni hisoblang. Chizmasini chizing.

626.  $L = ABC$  –siniq chiziq bo‘ylab ko‘rsatilgan yo‘nalishda berilgan  $\int_{ABC} (x^2 + y)dx - (y^2 + x)dy$  egri chiziqli integralni hisoblang.

Bunda,  $A(1;2)$ ,  $B(1;5)$ ,  $C(3;5)$ . Chizmasini chizing.

627.  $L: y=e^{-x}$  egri chiziqning  $A(0,1)$  nuqtasidan  $B(-1; e)$  nuqtasigacha bo‘lgan yoyi bo‘ylab ko‘rsatilgan yo‘nalishda berilgan  $\int_L ydx + \frac{x}{y} dy$  egri chiziqli integralni hisoblang.

Chizmasini chizing.

628.  $L=AB$  kesma bo‘ylab berilgan  $\int_{AB} \frac{y^2 + 1}{y} dx - \frac{x}{y^2} dy$  egri chiziqli integralni hisoblang. Bunda,  $A(1;2)$ ,  $V(2;4)$ . Chizmasini chizing.

629.  $L: y=2x^2$  parabolaning  $O(0;0)$  nuqtadan  $A(1;2)$  nuqtasigacha bo‘lgan yoyi bo‘ylab berilgan  $\int_{AB} (xy - x^2) dx + xdy$  egri chiziqli integralni hisoblang. Chizmasini chizing.

630.  $L: y=\ln x$  egri chiziqning  $A(1;0)$  nuqtadan  $B(e;1)$  nuqtasigacha bo‘lgan yoyi bo‘ylab berilgan  $\int_{AB} \frac{y}{x} dx + xdy$  egri chiziqli integralni hisoblang. Chizmasini chizing.

631.  $L: 2x+y=2$  to‘g‘ri chiziqning  $A(1;0)$  nuqtasidan  $B(0;2)$  nuqtasigacha bo‘lgan kesmasi bo‘ylab berilgan  $\int_L (xy - 1)dx + x^2 ydy$  egri chiziqli integralni hisoblang. Chizmasini chizing.

632.  $4x+y^2=4$  parabolaning  $A(1;0)$  nuqtasidan  $B(0;2)$  nuqtasigacha bo‘lgan yoyi bo‘ylab berilgan  $\int_L (xy - 1)dx + x^2 ydy$  egri chiziqli integralni hisoblang. Chizmasini chizing.

633.  $L: x=\cos t, y=2\sin t$  ellipsning  $A(1;0)$  nuqtasidan  $B(0;2)$  nuqtasigacha bo‘lgan yoyi bo‘ylab, ko‘rsatilgan yo‘nalishda

berilgan  $\int_L (xy - 1)dx + x^2 y dy$  egri chiziqli integralni hisoblang.

Chizmasini chizing.

634. L:  $y=2x$  to'g'ri chiziqning  $O(0;0)$  nuqtasidan  $A(1;2)$  nuqtasigacha bo'lgan kesmasi bo'ylab berilgan

$\int_L y(x - y)dx + x dy$  egri chiziqli integralni hisoblang. Chizmasini chizing.

635. L:  $y=2x^2$  parabolaning  $O(0;0)$  nuqtasidan  $A(1;2)$  nuqtasigacha bo'lgan yoyi bo'ylab berilgan  $\int_L y(x - y)dx + x dy$

egri chiziqli integralni hisoblang. Chizmasini chizing.

636. L:  $y^2=4x$  parabolaning  $O(0;0)$  nuqtadan  $A(1;2)$  nuqtasigacha

bo'lgan yoyi bo'ylab berilgan  $\int_L y(x - y)dx + x dy$  egri chiziqli

integralni hisoblang. Chizmasini chizing.

637. L :  $y-2x=2$  to'g'ri chiziqning  $A(-1;0)$  nuqtasidan  $B(0;2)$  nuqtasigacha bo'lgan kesmasi bo'ylab berilgan

$\int_L 2x dx - (x + 2y) dy$  egri chiziqli integralni hisoblang.

Chizmasini chizing.

638. L :  $x=2-y$  to'g'ri chiziqning  $B(0;2)$  nuqtasidan  $S(2;0)$  nuqtasigacha bo'lgan kesmasi bo'ylab berilgan

$\int_L 2x dx - (x + 2y) dy$  egri chiziqli integralni hisoblang. Chizmasini

chizing.

639. L :  $u=0$  to'g'ri chiziqning  $C(2;0)$  nuqtasidan  $A(-1;0)$  nuqtasigacha bo'lgan kesmasi bo'ylab berilgan

$\int_L 2x dx - (x + 2y) dy$  egri chiziqli integralni hisoblang. Chizmasini

chizing.



640.  $L : y=x^2$  parabolaning  $A(-3;9)$  nuqtasidan  $O(0;0)$  nuqtasigacha bo'lgan yoyi bo'ylab berilgan  $\int_L 2x(y-1)dx + x^2 dy$  egri chiziqli integralni hisoblang. Chizmasini chizing.

#### 4-§. TO'RTINCHI YOZMA ISH TOPSHIRIQLARI

##### Kompleks o'zgaruvchili funksiyalar

(641-660) Kompleks ifodaning qiymatini hisoblang.

641.  $(1-i)^{-1+i}$

642.  $(\frac{1-i}{\sqrt{2}})^{i+1}$

643.  $(3+4i)^i$

644.  $(3-4i)^{1+i}$

645.  $(2+2i)^{i+1}$

646.  $(1+\cos \frac{\pi}{3} + i \sin \frac{\pi}{3})^6$

647.  $(1-\sqrt{3}i)^{-1+i}$

648.  $(1+\cos \frac{\pi}{4} + i \sin \frac{\pi}{4})^6$

649.  $(-1-i)^i$

650.  $(-3+4i)^{1+i}$

651.  $(-1+i)^{\sqrt{-4+3i}}$

653.  $(\sqrt{3} - i)^{i+1}$

654.  $(\sqrt{-1})^i$

655.  $(3 + \sqrt{3}i)^{1+i}$

656.  $\sqrt{-1}$

657.  $(5+4i)^{1+i}$

658.  $(-1+i)^{\sqrt{1+i}}$

659.  $(-\sqrt{3}+3i)^i$

660.  $(1+i)^{1-i}$

2. (661-680) Berilgan kompleks o'zgaruvchili  $W=f(Z)$ , ( $Z=X+Yi$ ) funksiyani  $W=U(X,Y)+iV(X,Y)$  ko'rinishda yozing va uning analitikligini tekshiring. Agar  $W=f(Z)$  funksiya analitik bo'lsa, uning berilgan  $Z$  nuqtada hosilasini toping.

661.  $W = (iZ)^3$ ;  $Z_0 = -1 + i.$
662.  $W = i(1 - Z^2) - 2Z$ ;  $Z_0 = 1.$
663.  $W = e^{-z^2}$ ;  $Z_0 = i.$
664.  $W = e^{-1 - 2z}$ ;  $Z_0 = \frac{\pi \cdot i}{3}.$
665.  $W = Z^3 + 3Z - 1$ ;  $Z_0 = -i.$
666.  $W = e^{1 - 2zi}$ ;  $Z_0 = \frac{\pi}{6}.$
667.  $W = 2Z^2 - iZ$ ;  $Z_0 = 1 - i.$
668.  $W = e^{i \cdot z^2}$ ;  $Z_0 = \frac{\sqrt{\pi} \cdot i}{2}.$
669.  $W = Z^3 + Z^2 + i$ ;  $Z_0 = \frac{2 \cdot i}{3}.$
670.  $W = Z \cdot e^Z$ ;  $Z_0 = -1 + i\pi.$
671.  $W = \frac{1}{z}$ ;  $Z_0 = 1 + i.$
672.  $W = Z^3 + Z - 1$ ;  $Z_0 = 1 + i.$
673.  $W = Z^2 - Z$ ;  $Z_0 = 1 - i.$
674.  $W = Z^3$ ;  $Z_0 = 1 + 2i.$
675.  $W = e^{z^2}$ ;  $Z_0 = \frac{\pi \cdot i}{2}.$
676.  $W = \frac{1}{z}$ ;  $Z_0 = 3 - 2i.$

677.  $W=Z^3$ ;  
 678.  $W=Z^2+Z-1$ ;  
 679.  $W=Z^2+1$ ;  
 680.  $W=Z^2+1$ ;

- $Z_0 = 1-i$ .  
 $Z_0 = 1$ .  
 $Z_0 = 2-i$ .  
 $Z_0 = i$ .

3. (681-700) Berilgan  $f(z)$  funksiyani  $Z_0$  nuqta atrofida Loran qatoriga yoying va uning yaqinlashish sohasini toping:

681.  $f(z) = \frac{1}{3z-5}$ ;  $Z_0 = \frac{5}{3}$ .

691.  $f(z) = e^{\frac{z}{z-3}}$ ;  $Z_0 = 3$ .

682.  $f(z) = \text{Sin} \frac{z}{1-z}$ ;  $Z_0 = 1$ .

692.  $f(z) = \frac{1}{(z-1)(z+2)}$ ;  $Z_0 = 1$ .

683.  $f(z) = e^{\frac{1}{z}}$ ;  $Z_0 = 0$ .

693.  $f(z) = \frac{1}{2z+3}$ ;  $Z_0 = 1$ .

684.  $f(z) = e^{\frac{1}{1-z}}$ ;  $Z_0 = 1$ .

694.  $f(z) = \text{Cos} \frac{1}{z-i}$ ;  $Z_0 = i$ .

685.  $f(z) = \frac{1}{(z^2+1)^2}$ ;  $Z_0 = i$ .

695.  $f(z) = \frac{z}{z^2+1}$ ;  $Z_0 = \infty$ .

686.  $f(z) = \text{Ln} \frac{z-1}{z-2}$ ;  $Z_0 = 1$ .

696.  $f(z) = \frac{z}{4+z^2}$ ;  $Z_0 = 2i$ .

687.  $f(z) = \text{Cos} \frac{z}{z-1}$ ;  $Z_0 = 1$ .

697.  $f(z) = \frac{z^2}{z+1}$ ;  $Z_0 = -1$ .

688.  $f(z) = \frac{1}{z(z-1)}$ ;  $Z_0 = 0$ .

698.  $f(z) = \text{Ln} \frac{z}{z-1}$ ;  $Z_0 = 0$ .

689.  $f(z) = -\frac{z}{1+z^2}$ ;  $Z_0 = i$ .

699.  $f(z) = e^{\frac{z+1}{z}}$ ;  $Z_0 = 0$ .

690.  $f(z) = \frac{1}{(z-3)^2}$ ;  $Z_0 = 3$ .

700.  $f(z) = \text{Sin} \frac{1}{z}$ ;  $Z_0 = 0$ .

4. (701-720) Berilgan integralni hisoblang.

$$701. I = \int_{\Gamma} (x^2 + i \cdot y^2) dz, \text{ bu erda } G: Z_0 = 1+i \text{ nuqta bilan}$$

$Z_1 = 2+3i$  nuqtani tutashtiruvchi tug'ri chiziq.

$$702. I = \oint_{|z|=2} \frac{e^z dz}{z^2 - 1}.$$

$$703. I = \int_{\Gamma} (1 + i - z \cdot \bar{z}) dz, \text{ bu erda } \Gamma: y = x^2 \text{ parabolaning}$$

$z_0 = 0$  va  $z_1 = 1 + i$  nuqtalar oralig'idagi yoyi.

$$704. I = \oint_{|z-3|=6} \frac{z dz}{(z-2)^2(z+1)}.$$

$$705. I = \oint_{|z|=3} \frac{e^z \cos z dz}{z^2 + 2z}.$$

$$706. I = \int_{\Gamma} (z\bar{z} - \bar{z}^2) dz, \text{ bu erda } \Gamma: |z|=1, (-\pi \leq \arg z \leq 0).$$

$$707. I = \int_{\Gamma} e^{z^2} \operatorname{Im} z dz, \text{ bu erda } \Gamma: z_0 = 0 \text{ va } z_1 = 1 + i$$

nuqtalarni tutashtiruvchi to'g'ri chiziq.

$$708. I = \oint_{|z-1|=1} \frac{\sin(\pi z) dz}{(z^2 - 1)^2}.$$

$$709. I = \oint_{|z|=2} \frac{\sin z \cdot \sin(z-1) dz}{z^2 + z}.$$

$$710. I = \oint_{|z|=3} \frac{z^2 dz}{z - 2z}.$$

$$711. I = \int_{\Gamma} \frac{e^z}{(z^2 + 9)(z - \frac{1}{2})} dz, \text{ bu yerda } \Gamma: x^2 + y^2 = 2x + 2y + 4.$$

$$712. I = \oint_{\left| \frac{z-1}{2} \right|=1} \frac{\cos 2z dz}{(z-1)(z^2-1)}$$

$$713. I = \int_{|z|=4} \frac{e^{2z}}{z^2+9} dz.$$

$$714. I = \int_{|z+5i|=2} \frac{e^{z^2+5z+6}}{(z^2+16)(z+4i)} dz.$$

$$715. I = \int_{|z-3|=2} \frac{\cos z}{(z-3)(z^2-9)} dz.$$

$$716. I = \int_{|z-i|=2} \frac{\sin(2z^2+5)}{(z^2+4)(z-2i)} dz.$$

$$717. I = \int_{|z-1|=2} \frac{\sin(e^{z^2+3})}{(z^2-4)(z-2)} dz.$$

$$718. I = \int_{|z-8|=3} \frac{e^{z^2+4z}}{(z^2-49)(z-7)} dz.$$

$$719. I = \int_{|z+2|=2} \frac{3z^2-4z+3}{(z^2-9)(z+3)} dz.$$

$$720. I = \int_{|z|=4} \frac{\sin(iz)}{z^2-4z+3} dz.$$

### Ehtimollar nazariyasi va matematik statistika

5.(721-740) Berilgan hodisalarning ehtimolini toping:

721. Talaba dasturdagi 60 savoldan 45 tasini biladi. Har bir imtihon bileti uchta savoldan tashkil topgan. Quyidagi hodisalarning ehtimolini toping:

Talaba tushgan biletning:

- a) barcha uchta savolini biladi;
- b) faqat ikkita savolini biladi;
- v) faqat bitta savolini biladi.

722. Ikkita yashikning birida 5ta oq va ikkinchisida 10 ta qora shar bor. Birinchi yashikdan ikkinchisiga tavakkaliga bir shar olindi, so'ngra ikkinchi yashikdan tavakkaliga bir shar olindi. Olingan shar qora bo'lishligi ehtimolini toping.

723. Uchta mergan bir hil va bog'liqsiz sharoitda bitta mo'ljalga qarab bir martadan o'q uzishdi. Birinchi merganning mo'ljalga o'q tekkizish ehtimoli 0,9 ga, ikkinchisidiki 0,8 ga, uchinchisidiki esa, 0,7 ga teng. Quyidagi xodisalarning ehtimolini toping:

- a) faqat bir mergan mo'ljalga o'q tekkizdi;
- b) faqat ikkita mergan mo'ljalga o'q tekkizdi;
- v) uchta mergan ham mo'ljalga o'q tekkizdi.

724. Bir hil va bog'liqsiz tajribalarning har birida hodisaning ro'y berish ehtimoli 0,8 ga teng. 1600 tajribada hodisa 1200 marta ro'y berish ehtimolini toping.

725. Avariya ro'y berishini bildirish uchun bir-biridan bog'liq bo'lmagan holda ishlovchi uchta qurilma o'rnatilgan. Avariya vaqtida birinchi qurilma ishga tushishining ehtimoli 0,9 ga, ikkinchi qurilma ishga tushishining ehtimoli 0,95ga va uchinchisining ehtimoli 0,85 ga teng. Quyidagi hodisalarning ehtimoli topilsin: - avariya vaqtida:

- a) faqat bitta qurilma ishga tushishi.
- b) faqat ikkita qurilma ishga tushishi.
- v) barcha qurilmalar ishga tushishi.

726. Bir xil va bog'liqsiz tajribalarning har birida hodisaning ro'y berish ehtimoli 0,02 ga teng. 150 ta tajriba o'tkazilganda hodisa 5 marta ro'y berish ehtimolini toping.

727. 1000 dona tovarda 10 ta yaroqsiz tovar uchraydi. Shu 1000 dona tovardan tavakkaliga 50 dona olinganda ularning rosa 3 donasi yaroqsiz bo'lishligi ehtimolini toping.

728. Bir xil va bog'liqsiz tajribalarning har birida hodisaning ro'y berish ehtimoli 0,8 ga teng. 125 ta tajriba o'tkazilganda

hodisa 75 dan kam bo'lmagan va 90 dan ko'p bo'lmagan marta ro'y berish ehtimolini toping.

729. Uchta dastgohda bir xil va bog'liqsiz sharoitda bir turli detal tayyorlanadi. Birinchi dastgohda 10%, ikkinchisida 30% va uchinchisida 60% detal tayyorlanadi. Har bir detalning yaroqli bo'lib tayyorlanish ehtimoli: birinchi dastgohda 0,7 ga, ikkinchisida 0,8 ga va uchinchisida 0,9 ga teng. Barcha tayyorlangan detallardan tavakkaliga olingan detalning yaroqli bo'lishi ehtimolini toping.

730. Aka-uka har biri 12 kishidan iborat ikkita sport komandasiga qatnashadilar. Ikki yashikda 1 dan 12 gacha nomerlangan 12 ta bilet bor. Har bir komanda a'zolari tavakkaliga bittadan biletni aniq bir yashikdan olishadi. Olingan bilet yashik qaytarilmaydi. Ikkala aka-ukaning 6- nomerli bilet olishligi ehtimoli topilsin.

731. Uchta quroldan bir vaqtda mo'ljalga qarab o'q uzishdi. Bir otishda mo'ljalga tekkizish ehtimoli birinchi qurol uchun 0,8 ga, ikkinchisiga 0,7 ga va uchinchisiga esa, 0,9 ga teng. Quyidagi hodisalarning ehtimolini toping:

- a) faqat bir o'qning mo'ljalga tegishi;
- b) faqat ikkita o'qning mo'ljalga tegishi;
- v) barcha uchta o'qning mo'ljalga tegishi;
- g) hech bo'lmaganda bir o'qning mo'ljalga tegishi.

732. Uch mergan bir vaqtda mo'ljalga o'q uzishdi. Mo'ljalga o'q tekkizish ehtimoli birinchi mergan uchun 0,7 ga, ikkinchisiga 0,8 ga, uchinchisiga esa 0,9 ga teng. Quyidagi hodisalarning ehtimolini toping:

- a) faqat bir mergan mo'ljalga o'q tekkizishi;
- b) faqat ikki mergan mo'ljalga o'q tekkizishi;
- v) barcha uchta mergan mo'ljalga o'q tekkizishi;
- g) hech bo'lmaganda bitta mergan mo'ljalga o'q tekkizishi.

733. Talaba dasturning 60 ta savolidan 50 tasini biladi. Imtihon bileti 3 ta savoldan iborat. Quyidagi hodisalarning ehtimolini toping: Talaba:

- a) faqat ikkita savolni biladi;
- b) uchta savolni biladi;
- v) hech bo'lmaganda bitta savolni biladi.

734. Har biri 10 sportchidan iborat ikki komanda musobaqa qatnashchilariga nomer berish uchun qurra tashlashmoqda. Ikki aka-uka turli komandalarning a'zosi dirlar. Aka-ukaning ikkalasi ham musobaqada 5- nomer bilan qatnashish ehtimolini toping.

735. Ikki mergan mo'ljalga bittadan o'q uzishdi. Har bir merganning mo'ljalga o'q tekkizish ehtimoli 0,8 ga teng. Quyidagi hodisalarning ehtimolini toping:

- a) ikkala mergan mo'ljalga o'q tekkizishdi;
- b) ikkala mergan mo'ljalga o'q tekkizishmadi;
- v) hech bo'lmaganda bir mergan mo'ljalga o'q tekkizdi.

736. Ikki o'q otishda hech bo'lmaganda bir marta mo'ljalga o'q tekkizish ehtimoli 0,96 ga teng. To'rt marta o'q otishda uch marta mo'ljalga o'q tekkizish ehtimolini toping.

737. Nashriyot ikkita aloqa bo'limiga gazetalar yuboradi. O'z vaqtida gazeta etib borishi ehtimoli har bir aloqa bo'limi uchun 0,9 ga teng. Quyidagi hodisalarning ehtimolini toping:

- a) ikkala aloqa bo'limiga o'z vaqtida gazeta etib borishi;
- b) faqat bir aloqa bo'limiga o'z vaqtida gazeta etib borishi;
- v) hech bo'lmaganda bitta aloqa bo'limiga o'z vaqtida gazeta etib borishi.

738. Ikkita yashikning har birida 2 ta qora va 8 ta oq shar bor. Birinchi yashikdan tavakkaliga bir shar olinib, ikkinchi yashikka solindi. So'ngra ikkinchi yashikdan bir shar olindi. Ikkinchi yashikdan olingan shar oq bo'lishligining ehtimolini toping.

739. Ikkita harf teruvchilar bir xil hajmda harf terdilar. Birinchi harf teruvchi xatoga yo'l qo'yishining ehtimoli 0,051 ga teng, ikkinchisi xatoga yo'l qo'yishining ehtimoli 0,1 ga teng. Terilgan harflar tekshirilganda xato topishdi. Bu xatoga birinchi harf teruvchi yo'l qo'yanligining ehtimolini toping.

740. Bog'liqsiz tajribalarning har birida hodisaning ro'y berishi ehtimoli 0,8 ga teng. 100 ta tajriba o'tkazilganda hodisaning 70 dan kam bo'lmaganda va 80 dan ortiq bo'lmaganda marta ro'y berishligining ehtimolini toping.

6. (741-760) Diskret tasodifiy miqdor  $X$  faqat ikkita  $x_1$  va  $x_2$  qiymat qabul qiladi va  $x_1 < x_2$ .  $X$  ning  $x_1$  qiymatini qabul qilish



ehtimoli  $p_i$  ma'lum, matematik kutilmasi  $M(X)$  va dispersiyasi  $D(X)$  ma'lum. Bu tasodifiy miqdorning taqsimot qonunini toping.

| No  | $P_i$ | $M(X)$ | $D(X)$ | No  | $P_i$ | $M(X)$ | $D(X)$ |
|-----|-------|--------|--------|-----|-------|--------|--------|
| 741 | 0,1   | 1,9    | 0,09   | 751 | 0,2   | 5,8    | 0,16   |
| 742 | 0,2   | 2,8    | 0,16   | 752 | 0,3   | 6,7    | 0,21   |
| 743 | 0,3   | 3,7    | 0,21   | 753 | 0,4   | 1,6    | 0,24   |
| 744 | 0,4   | 4,6    | 0,24   | 754 | 0,5   | 2,5    | 0,25   |
| 745 | 0,5   | 5,5    | 0,25   | 755 | 0,6   | 3,4    | 0,24   |
| 746 | 0,6   | 6,4    | 0,24   | 756 | 0,7   | 4,3    | 0,21   |
| 747 | 0,7   | 1,3    | 0,21   | 757 | 0,8   | 5,2    | 0,16   |
| 748 | 0,8   | 2,2    | 0,16   | 758 | 0,9   | 6,1    | 0,09   |
| 749 | 0,9   | 3,1    | 0,09   | 759 | 0,1   | 1,2    | 0,36   |
| 750 | 0,1   | 4,9    | 0,09   | 760 | 0,2   | 3,8    | 0,16   |

7. (761-780)  $X$  – tasodifiy miqdor o'zining taqsimot funksiyasi  $F(x)$  bilan berilgan. Uning zichlik funksiyasi, matematik kutilmasi va dispersiyasi topilsin. Taqsimot va zichlik funksiyalarining grafigi chizilsin.

$$761. F(x) = \begin{cases} 0 & \text{agar } x \leq 0 \\ x^2 & \text{agar } 0 < x \leq 1 \\ 1 & \text{agar } x > 1 \end{cases}$$

$$762. F(x) = \begin{cases} 0 & \text{agar } x \leq 1 \\ \frac{1}{10}(3x^2 + x - 4) & \text{agar } 1 < x \leq 2 \\ 1 & \text{agar } x > 2 \end{cases}$$

$$763. F(x) = \begin{cases} 0 & \text{agar } x \leq -0,2 \\ 5x + 1 & \text{agar } -0,2 < x \leq 0 \\ 1 & \text{agar } x > 0 \end{cases}$$

$$764. F(x) = \begin{cases} 0 & \text{agar } x \leq -\pi \\ \sqrt{2} \cos \frac{x}{2} & \text{agar } -\pi < x \leq \frac{\pi}{2} \\ 1 & \text{agar } x > \frac{\pi}{2} \end{cases}$$

$$765. F(x) = \begin{cases} 0 & \text{agar } x \leq 0 \\ \frac{\sqrt{x}}{2} & \text{agar } 0 < x \leq 4 \\ 1 & \text{agar } x > 4 \end{cases}$$

$$766. F(x) = \begin{cases} 0 & \text{agar } x \leq 4 \\ \ln \frac{x}{2} & \text{agar } 4 < x \leq 4e \\ 1 & \text{agar } x > 4e \end{cases}$$

$$767. F(x) = \begin{cases} 0 & \text{agar } x \leq 0 \\ \frac{1}{3}(2x^2 + x) & \text{agar } 0 < x \leq 1 \\ 1 & \text{agar } x > 1 \end{cases}$$

$$768. F(x) = \begin{cases} 0 & \text{agar } x \leq 0 \\ \frac{1}{2}(x^3 + x) & \text{agar } 0 < x \leq 1 \\ 1 & \text{agar } x > 1 \end{cases}$$

$$769. F(x) = \begin{cases} 0 & \text{agar } x \leq 0 \\ 3x^2 + 2x & \text{agar } 0 < x \leq \frac{1}{3} \\ 1 & \text{agar } x > \frac{1}{3} \end{cases}$$

$$770. F(x) = \begin{cases} 0 & \text{agar } x \leq 0 \\ 2 \sin x & \text{agar } 0 < x \leq \frac{\pi}{6} \\ 1 & \text{agar } x > \frac{\pi}{6} \end{cases}$$

$$771. F(x) = \begin{cases} 0 & \text{agar } x \leq 1 \\ \frac{1}{6}(x^2 + 3x - 4) & \text{agar } 1 < x \leq 2 \\ 1 & \text{agar } x > 2 \end{cases}$$

$$772. F(x) = \begin{cases} 0 & \text{agar } x \leq \frac{1}{3} \\ \frac{1}{5}(3x-1) & \text{agar } \frac{1}{3} < x \leq 2 \\ 1 & \text{agar } x > 2 \end{cases}$$

$$773. F(x) = \begin{cases} 0 & \text{agar } x \leq 0 \\ x^3 & \text{agar } 0 < x \leq 1 \\ 1 & \text{agar } x > 1 \end{cases}$$

$$774. F(x) = \begin{cases} 0 & \text{agar } x \leq -1 \\ \sqrt{x+1} & \text{agar } -1 < x \leq 0 \\ 1 & \text{agar } x > 0 \end{cases}$$

$$775. F(x) = \begin{cases} 0 & \text{agar } x \leq 3 \\ \text{Ln} \frac{x}{3} & \text{agar } 3 < x \leq 3e \\ 1 & \text{agar } x > 3e \end{cases}$$

$$776. F(x) = \begin{cases} 0 & \text{agar } x \leq \frac{3\pi}{4} \\ \cos 2x & \text{agar } \frac{3\pi}{4} < x \leq \pi \\ 1 & \text{agar } x > \pi \end{cases}$$

$$777. F(x) = \begin{cases} 0 & \text{agar } x \leq -1 \\ x^2 & \text{agar } -1 < x \leq 1 \\ 1 & \text{agar } x > 1 \end{cases}$$

$$778. F(x) = \begin{cases} 0 & \text{agar } x \leq 0 \\ \frac{x^2}{9} & \text{agar } 0 < x \leq 3 \\ 1 & \text{agar } x > 3 \end{cases}$$

$$779. F(x) = \begin{cases} 0 & \text{agar } x \leq 0 \\ \frac{1}{4}(x^3 - 2x) & \text{agar } 0 < x \leq 2 \\ 1 & \text{agar } x > 2 \end{cases}$$

$$780. F(x) = \begin{cases} 0 & \text{agar } x \leq 2 \\ \frac{1}{2}(x^2 - 3x) & \text{agar } 2 < x \leq 3 \\ 1 & \text{agar } x > 3 \end{cases}$$

8. (781-800) Normal taqsimlangan  $X$ - tasodifiy miqdorning matematik kutilmasi  $a$  va o'rtacha kvadratik chetlashishi  $\sigma$ -lar berilgan. Bu tasodifiy miqdorning berilgan  $(\alpha; \beta)$  intervalga tushishligining ehtimolini toping:

| №   | $a$ | $\sigma$ | $\alpha$ | $\beta$ | №   | $a$ | $\sigma$ | $\alpha$ | $\beta$ |
|-----|-----|----------|----------|---------|-----|-----|----------|----------|---------|
| 781 | 2   | 6        | 4        | 9       | 791 | 12  | 4        | 7        | 18      |
| 782 | 3   | 2        | 3        | 10      | 792 | 13  | 5        | 9        | 18      |
| 783 | 4   | 2        | 2        | 10      | 793 | 14  | 9        | 11       | 17      |
| 784 | 5   | 4        | 5        | 9       | 794 | 15  | 8        | 9        | 21      |
| 785 | 6   | 2        | 4        | 12      | 795 | 16  | 6        | 12       | 9       |
| 786 | 7   | 2        | 3        | 10      | 796 | 17  | 11       | 9        | 20      |
| 787 | 8   | 5        | 3        | 15      | 797 | 18  | 6        | 10       | 22      |
| 788 | 9   | 6        | 5        | 14      | 798 | 19  | 7        | 11       | 23      |
| 789 | 10  | 4        | 2        | 13      | 799 | 20  | 7        | 13       | 24      |
| 790 | 11  | 5        | 7        | 17      | 800 | 21  | 9        | 9        | 15      |

9. (801-820) Tanlanma o'rtacha qiymati  $\bar{x}$  ga, tanlanma hajmi  $n$  ga va o'rtacha kvadratik chetlashishi  $\sigma$  ga teng bo'lgan normal taqsimotning matematik kutilmasi  $a$  ning bahosi uchun 0,95 ishonchlik bilan ishonch intervalini toping:

| №   | $\bar{x}$ | $n$ | $\sigma$ | №   | $\bar{x}$ | $n$ | $\sigma$ |
|-----|-----------|-----|----------|-----|-----------|-----|----------|
| 801 | 74,69     | 25  | 2,5      | 811 | 74,79     | 225 | 7,5      |
| 802 | 74,70     | 36  | 3        | 812 | 74,80     | 256 | 8        |
| 803 | 74,71     | 49  | 3,5      | 813 | 74,81     | 289 | 8,5      |
| 804 | 74,72     | 64  | 4        | 814 | 74,82     | 324 | 9        |
| 805 | 74,73     | 81  | 4,5      | 815 | 74,83     | 381 | 9,5      |
| 806 | 74,74     | 100 | 5        | 816 | 74,84     | 400 | 10       |
| 807 | 74,75     | 121 | 5,5      | 817 | 74,85     | 441 | 10,5     |
| 808 | 74,76     | 144 | 6        | 818 | 74,86     | 484 | 11       |
| 809 | 74,77     | 169 | 6,5      | 819 | 74,87     | 529 | 11,5     |
| 810 | 74,78     | 196 | 7        | 820 | 74,88     | 576 | 12       |

## ADABIYOTLAR

- 1) Piskunov I.S. Differensialnoye i integralnoye ischisleniye. M., Nauka. 1984g. 1-2 t.
- 2) Bermant A.F. Kratkiy kurs matematicheskogo analiza. Dlya vtuzov. M. Nauka. 1985 g.
- 3) Berman G.N. Sbornik zadach po kursu matematicheskogo analiza. M., Nauka. 1985 g.
- 4) Ignatyeva A.V. i drugie. Kurs visshey matematiki. M., «Visshaya shkola» 1968 g.
- 5) Kudryavsev V.A. i drugie. Kratkiy kurs visshey matematiki. M., 1962 g.
- 6) Pod redaksiyey Yefimova A.V., Demidovicha B.P. Sbornik zadach po matematike dlya vtuzov. M., Nauka. 1-4 t.
- 7) Lixoletov I.I., Maskevich I.P. Rukovodstvo k resheniyu zadach po visshey matematike, teorii veroyatnostey i matematicheskoy statistike. Minsk., «Visheyshaya shkola» 1969 g.
- 8) Mishkis A.D. Leksiy po visshey matematike. M., Nauka. 1973 g.
- 9) Gmurman V.E. Teoriya veroyatnostey i matematicheskaya statistika. M., 1972 g.
- 10) V. E. Gmurman. Ehtimollar nazariyasi va matematik statistikadan masalalar yechishga doir qo'llanmalar. T., "O'qituvchi". 1980 y.
- 11) Azlarov T.A., Mansurov X. Matematik analiz. T., "O'qituvchi". 1-2-3-jild. 1989 y.
- 12) Danko P.S., Popov A.G., Kojevnikova T.YA. Visshaya matematika v uprajneniyax i zadachax. M. Visshaya shkola. 1985 g. 1-2 ch.
- 13) Soatov YO. U. Oliy matematika. "O'qituvchi". 1994. 1-2 qism.
- 14) Latipov X.R., Tojiev Sh. Analitik geometriya va chiziqli algebra. T., «O'zbekiston». 1995 y.
- 15) Latipov X.R., Nosirov F.U., Tojiev Sh.I. Analitik geometriya va chiziqli algebradan masalalar yechish bo'yicha qo'llannia. «Fan». 1998 y.

## Yozma ish variantlari

| №<br>var | Birinci yozma ish |    |    |    |     |     |     |     |     |     |     |     |
|----------|-------------------|----|----|----|-----|-----|-----|-----|-----|-----|-----|-----|
|          | 1                 | 1  | 21 | 41 | 61  | 81  | 101 | 121 | 141 | 161 | 181 | 201 |
| 2        | 2                 | 22 | 42 | 62 | 82  | 102 | 122 | 142 | 162 | 182 | 202 | 222 |
| 3        | 3                 | 23 | 43 | 63 | 83  | 103 | 123 | 143 | 163 | 183 | 203 | 223 |
| 4        | 4                 | 24 | 44 | 64 | 84  | 104 | 124 | 144 | 164 | 184 | 204 | 224 |
| 5        | 5                 | 25 | 45 | 65 | 85  | 105 | 125 | 145 | 165 | 185 | 205 | 225 |
| 6        | 6                 | 26 | 46 | 66 | 86  | 106 | 126 | 146 | 166 | 186 | 206 | 226 |
| 7        | 7                 | 27 | 47 | 67 | 87  | 107 | 127 | 147 | 167 | 187 | 207 | 227 |
| 8        | 8                 | 28 | 48 | 68 | 88  | 108 | 128 | 148 | 168 | 188 | 208 | 228 |
| 9        | 9                 | 29 | 49 | 69 | 89  | 109 | 129 | 149 | 169 | 189 | 209 | 229 |
| 10       | 10                | 30 | 50 | 70 | 90  | 110 | 130 | 150 | 170 | 190 | 210 | 230 |
| 11       | 11                | 31 | 51 | 71 | 91  | 111 | 131 | 151 | 171 | 191 | 211 | 231 |
| 12       | 12                | 32 | 52 | 72 | 92  | 112 | 132 | 152 | 172 | 192 | 212 | 232 |
| 13       | 13                | 33 | 53 | 73 | 93  | 113 | 133 | 153 | 173 | 193 | 213 | 233 |
| 14       | 14                | 34 | 54 | 74 | 94  | 114 | 134 | 154 | 174 | 194 | 214 | 234 |
| 15       | 15                | 35 | 55 | 75 | 95  | 115 | 135 | 155 | 175 | 195 | 215 | 235 |
| 16       | 16                | 36 | 56 | 76 | 96  | 116 | 136 | 156 | 176 | 196 | 216 | 236 |
| 17       | 17                | 37 | 57 | 77 | 97  | 117 | 137 | 157 | 177 | 197 | 217 | 237 |
| 18       | 18                | 38 | 58 | 78 | 98  | 118 | 138 | 158 | 178 | 198 | 218 | 238 |
| 19       | 19                | 39 | 59 | 79 | 99  | 119 | 139 | 159 | 179 | 199 | 219 | 239 |
| 20       | 20                | 40 | 60 | 80 | 100 | 120 | 140 | 160 | 180 | 200 | 220 | 240 |

| <b>No var.</b> | <b>Ikkinchi yozma ish</b> |     |     |     |     |     |     |     |     |     |
|----------------|---------------------------|-----|-----|-----|-----|-----|-----|-----|-----|-----|
| <b>1</b>       | 241                       | 261 | 281 | 301 | 321 | 341 | 361 | 381 | 401 | 421 |
| <b>2</b>       | 242                       | 262 | 282 | 302 | 322 | 342 | 362 | 382 | 402 | 422 |
| <b>3</b>       | 243                       | 263 | 283 | 303 | 323 | 343 | 363 | 383 | 403 | 423 |
| <b>4</b>       | 244                       | 264 | 284 | 304 | 324 | 344 | 364 | 384 | 404 | 424 |
| <b>5</b>       | 245                       | 265 | 285 | 305 | 325 | 345 | 365 | 385 | 405 | 425 |
| <b>6</b>       | 246                       | 266 | 286 | 306 | 326 | 346 | 366 | 386 | 406 | 426 |
| <b>7</b>       | 247                       | 267 | 287 | 307 | 327 | 347 | 367 | 387 | 407 | 427 |
| <b>8</b>       | 248                       | 268 | 288 | 308 | 328 | 348 | 368 | 388 | 408 | 428 |
| <b>9</b>       | 249                       | 269 | 289 | 309 | 329 | 349 | 369 | 389 | 409 | 429 |
| <b>10</b>      | 250                       | 270 | 290 | 310 | 330 | 350 | 370 | 390 | 410 | 430 |
| <b>11</b>      | 251                       | 271 | 291 | 311 | 331 | 351 | 371 | 391 | 411 | 431 |
| <b>12</b>      | 252                       | 272 | 292 | 312 | 332 | 352 | 372 | 392 | 412 | 432 |
| <b>13</b>      | 253                       | 273 | 293 | 313 | 333 | 353 | 373 | 393 | 413 | 433 |
| <b>14</b>      | 254                       | 274 | 294 | 314 | 334 | 354 | 374 | 394 | 414 | 434 |
| <b>15</b>      | 255                       | 275 | 295 | 315 | 335 | 355 | 375 | 395 | 415 | 435 |
| <b>16</b>      | 256                       | 276 | 296 | 316 | 336 | 356 | 376 | 396 | 416 | 436 |
| <b>17</b>      | 257                       | 277 | 297 | 317 | 337 | 357 | 377 | 397 | 417 | 437 |
| <b>18</b>      | 258                       | 278 | 298 | 318 | 338 | 358 | 378 | 398 | 418 | 438 |
| <b>19</b>      | 259                       | 279 | 299 | 319 | 339 | 359 | 379 | 399 | 419 | 439 |
| <b>20</b>      | 260                       | 280 | 300 | 320 | 340 | 360 | 380 | 400 | 420 | 440 |

| №<br>var. | Uchinchi yozma ish |     |     |     |     |     |     |     |     |     |
|-----------|--------------------|-----|-----|-----|-----|-----|-----|-----|-----|-----|
| 1         | 441                | 461 | 481 | 501 | 521 | 541 | 561 | 581 | 601 | 621 |
| 2         | 442                | 462 | 482 | 502 | 522 | 542 | 562 | 582 | 602 | 622 |
| 3         | 443                | 463 | 483 | 503 | 523 | 543 | 563 | 583 | 603 | 623 |
| 4         | 444                | 464 | 484 | 504 | 524 | 544 | 564 | 584 | 604 | 624 |
| 5         | 445                | 465 | 485 | 505 | 525 | 545 | 565 | 585 | 605 | 625 |
| 6         | 446                | 466 | 486 | 506 | 526 | 546 | 566 | 586 | 606 | 626 |
| 7         | 447                | 467 | 487 | 507 | 527 | 547 | 567 | 587 | 607 | 627 |
| 8         | 448                | 468 | 488 | 508 | 528 | 548 | 568 | 588 | 608 | 628 |
| 9         | 449                | 469 | 489 | 509 | 529 | 549 | 569 | 589 | 609 | 629 |
| 10        | 450                | 470 | 490 | 510 | 530 | 550 | 570 | 590 | 610 | 630 |
| 11        | 451                | 471 | 491 | 511 | 531 | 551 | 571 | 591 | 611 | 631 |
| 12        | 452                | 472 | 492 | 512 | 532 | 552 | 572 | 592 | 612 | 632 |
| 13        | 453                | 473 | 493 | 513 | 533 | 553 | 573 | 593 | 613 | 633 |
| 14        | 454                | 474 | 494 | 514 | 534 | 554 | 574 | 594 | 614 | 634 |
| 15        | 455                | 475 | 495 | 515 | 535 | 555 | 575 | 595 | 615 | 635 |
| 16        | 456                | 476 | 496 | 516 | 536 | 556 | 576 | 596 | 616 | 636 |
| 17        | 457                | 477 | 497 | 517 | 537 | 557 | 577 | 597 | 617 | 637 |
| 18        | 458                | 478 | 498 | 518 | 538 | 558 | 578 | 598 | 618 | 638 |
| 19        | 459                | 479 | 499 | 519 | 539 | 559 | 579 | 599 | 619 | 639 |
| 20        | 460                | 480 | 500 | 520 | 540 | 560 | 580 | 600 | 620 | 640 |



| №<br>var. | To'rtinchi yozma ish |     |     |     |     |     |     |     |     |
|-----------|----------------------|-----|-----|-----|-----|-----|-----|-----|-----|
| 1         | 641                  | 661 | 681 | 701 | 721 | 741 | 761 | 781 | 801 |
| 2         | 642                  | 662 | 682 | 702 | 722 | 742 | 762 | 782 | 802 |
| 3         | 643                  | 663 | 683 | 703 | 723 | 743 | 763 | 783 | 803 |
| 4         | 644                  | 664 | 684 | 704 | 724 | 744 | 764 | 784 | 804 |
| 5         | 645                  | 665 | 685 | 705 | 725 | 745 | 765 | 785 | 805 |
| 6         | 646                  | 666 | 686 | 706 | 726 | 746 | 766 | 786 | 806 |
| 7         | 647                  | 667 | 687 | 707 | 727 | 747 | 767 | 787 | 807 |
| 8         | 648                  | 668 | 688 | 708 | 728 | 748 | 768 | 788 | 808 |
| 9         | 649                  | 669 | 689 | 709 | 729 | 749 | 769 | 789 | 809 |
| 10        | 650                  | 670 | 690 | 710 | 730 | 750 | 770 | 790 | 810 |
| 11        | 651                  | 671 | 691 | 711 | 731 | 751 | 771 | 791 | 811 |
| 12        | 652                  | 672 | 692 | 712 | 732 | 752 | 772 | 792 | 812 |
| 13        | 653                  | 673 | 693 | 713 | 733 | 753 | 773 | 793 | 813 |
| 14        | 654                  | 674 | 694 | 714 | 734 | 754 | 774 | 794 | 814 |
| 15        | 655                  | 675 | 695 | 715 | 735 | 755 | 775 | 795 | 815 |
| 16        | 656                  | 676 | 696 | 716 | 736 | 756 | 776 | 796 | 816 |
| 17        | 657                  | 677 | 697 | 717 | 737 | 757 | 777 | 797 | 817 |
| 18        | 658                  | 678 | 698 | 718 | 738 | 758 | 778 | 798 | 818 |
| 19        | 659                  | 679 | 699 | 719 | 739 | 759 | 779 | 799 | 819 |
| 20        | 660                  | 680 | 700 | 720 | 740 | 760 | 780 | 800 | 820 |

H. R. LATIPOV, R. R. ABZALIMOV,  
I. K. URAZBAYEVA

## OLIV MATEMATIKA

Toshkent – “Aloqachi” – 2005

|               |                      |
|---------------|----------------------|
| Muharrir      | <i>M. Mirkomilov</i> |
| Tex. muharrir | <i>A. Moydinov</i>   |
| Musahhih      | <i>Q. Avezbayev</i>  |

Bosishga ruxsat etildi 10.12.05. Bichimi 60×841/16.

Nashr tabog'i 11,25. Adadi 1000. Buyurtma №107.

“Aloqachi” nashriyoti, 700000, Toshkent shahri,

A. Temur ko'chasi, 108-uy.

Shartnoma №25-05.

«Aloqachi» nashriyot matbaa  
markazining bosmaxonasida chop etildi.