



Library Hi Tech

Developing and implementing 3D printing services in an academic library
Gillian Andrea Nowlan

Article information:

To cite this document:

Gillian Andrea Nowlan , (2015),"Developing and implementing 3D printing services in an academic library", Library Hi Tech, Vol. 33 Iss 4 pp. 472 - 479

Permanent link to this document:

<http://dx.doi.org/10.1108/LHT-05-2015-0049>

Downloaded on: 15 November 2016, At: 22:28 (PT)

References: this document contains references to 13 other documents.

To copy this document: permissions@emeraldinsight.com

The fulltext of this document has been downloaded 1018 times since 2015*

Users who downloaded this article also downloaded:

(2015),"When makerspaces go mobile: case studies of transportable maker locations", Library Hi Tech, Vol. 33 Iss 4 pp. 462-471 <http://dx.doi.org/10.1108/LHT-06-2015-0061>

(2015),"What to make of makerspaces: Tools and DIY only or is there an interconnected information resources space?", Library Hi Tech, Vol. 33 Iss 4 pp. 519-525 <http://dx.doi.org/10.1108/LHT-09-2015-0092>

Access to this document was granted through an Emerald subscription provided by emerald-srm:563821 []

For Authors

If you would like to write for this, or any other Emerald publication, then please use our Emerald for Authors service information about how to choose which publication to write for and submission guidelines are available for all. Please visit www.emeraldinsight.com/authors for more information.

About Emerald www.emeraldinsight.com

Emerald is a global publisher linking research and practice to the benefit of society. The company manages a portfolio of more than 290 journals and over 2,350 books and book series volumes, as well as providing an extensive range of online products and additional customer resources and services.

Emerald is both COUNTER 4 and TRANSFER compliant. The organization is a partner of the Committee on Publication Ethics (COPE) and also works with Portico and the LOCKSS initiative for digital archive preservation.

*Related content and download information correct at time of download.

Developing and implementing 3D printing services in an academic library

Gillian Andrea Nowlan
University of Regina, Regina, Canada

Received 13 May 2015
Revised 30 June 2015
Accepted 15 July 2015

Abstract

Purpose – The purpose of this paper is to describe the development of a 3D printing pilot project and 3D printing library service. Policy development, instruction, and best practices will be shared and explored.

Design/methodology/approach – This paper describes the implementation of 3D printing at the University of Regina Library and details successes, failures, and modifications made to better provide 3D printing services. This paper outlines one academic library's experience and solutions to offering 3D printing for university patrons.

Findings – Although 3D printing has been around for a while, it still requires trial and error and experience in order to print successfully. Training and instruction is needed to run the 3D printer and understand how to develop 3D objects that will print successfully.

Originality/value – There have been many publications on 3D printing, but few that discuss problem solving, best practices, and policy development. 3D printing provides a way for patrons to learn about new technology and use that technology to help support learning.

Keywords Academic libraries, 3D printing, 3D technology, Makerspace

Paper type Case study

Introduction

Although it sounds very futuristic, 3D printing has been around for almost 30 years but has only recently become easily accessible to small businesses, libraries, and even individuals. There are three different types of 3D printers available. Moorefield-Lang describes the three different types of printers available to consumers: fused deposition modeling (FDM) (melting and layering plastic), stereolithography (using ultraviolet light to solidify an object in photosensitive liquid), and selective laser sintering (powders and lasers are used to create objects). At the University of Regina Library we are working with a MakerBot fifth generation printer which is a FDM printer. This type of printing is the most popular to date, where plastic filament is melted and layered to create a 3D object (Moorefield-Lang, 2014a). Its popularity is mostly due to a more reasonable cost and the type of materials used to create 3D objects.

This paper discusses the operational process of the University of Regina Library's 3D printer, how to implement a 3D printing service, why academic libraries should provide 3D printing services on campus, some inherent issues that were experienced during the pilot project, and best practices developed from trial and error during the pilot phase of our 3D printing project. A basic literature review of current 3D printing services in libraries will also be provided to give some context for what has been accomplished with 3D printing in libraries to date.

Background

Review of the literature

FDM 3D printers use an additive process where plastic is melted at high temperatures and laid down in a specific pattern to create a 3D object (Kurt and Colegrove, 2012).



There are two different types of materials that can be used to create objects with an FDM printer: acrylonitrile butadiene styrene (ABS) and polylactic acid (PLA). The University of Regina Library owns one MakerBot fifth generation model that prints only with PLA filament. PLA is derived from plant-based materials so the printing process does not produce any toxic fumes or smell, allowing our printer to be located on the main floor in a highly visible area. This not only allows students and faculty to watch their prints, but it also promotes the service. ABS is slightly more flexible, which allows interlocking and connecting pieces to snap and fit together with ease, but the plastic gives off fumes and ventilation would be required in a public location to avoid health and safety hazards (Jamaluddin, 2013).

Many academic libraries have chosen to incorporate 3D printing into their space as libraries “provide an environment that traditionally supports creative thinking and collaboration” (Gonzalez and Bennett, 2014). The literature suggests that the library is a key place for this type of technology because the library is open long hours and is an access point for all academic disciplines (Gonzalez and Bennett, 2014). Libraries have always been a place where learning of all kinds can take place, including the development of digital literacies and technological literacies. This makes libraries a perfect place to house new technologies and provide access and instruction to the community they serve.

The literature notes varying types of usage and success levels with 3D printing projects. Dalhousie University Libraries was one of the first Canadian universities to adopt a full 3D printing program. In their article, “3D printing and scanning at the Dalhousie University Libraries,” they describe a fairly steep learning curve for those who are not familiar or comfortable with technology (Groenendyk and Gallant, 2013). Dalhousie Libraries has had success with their fleet of 3D printers (all FDM) but the most challenging issue is learning how to configure the software settings which will allow the object to be printed successfully. MakerBot offers a free software program that permits some level of customization. For example, infill levels can be selected, which determines if the entire object will be filled with plastic or if a honeycomb semi-fill structure will be used, making the inside of the object semi-hollow. These types of selections will make objects stronger and determine the final weight. Supports are another setting that produces dotted plastic that is added to the object to support overhanging parts of the model. These dotted plastic pieces can be torn away once the model is finished printing. Rafts can be added and consist of an additional plastic platform that is printed for the object to be printed on. This helps the print job adhere to the build plate and ensures it does not pop off during printing, resulting in errors. Print resolution/speed settings determine the level of detail the printer can capture. A faster print job will not capture small details as well as a slower print job. The literature on 3D printing notes some difficulty in determining the best settings for a variety of different objects that may require support or higher infill in order to print successfully. Experience and trial and error are usually required in order to determine the best settings for different types of 3D models.

The importance of instruction and targeted sessions are essential as inexperience will limit the overall use of 3D printers (Moorefield-Lang, 2014a). Sessions could include demonstrations on the operation of the 3D printer or on developing objects from 3D modeling software. Moorefield-Lang notes that exploring failed 3D prints is also of great value, as learning from printing errors helps improve the setup of future prints and teach patrons how to build proper models. In addition to the free MakerBot software there are also many open source software programs that provide 3D modeling tools, such as FreeCAD, Solid Edge, and Google SketchUp.

3D printing is commonly part of an overall makerspace in libraries. Many public libraries have incorporated 3D printing into their makerspaces, which helps to encourage new ways of learning and the opportunity to try new technology (Fisher, 2012). Many of these makerspaces include technology such as 3D printing, but can be made up of anything that allows individuals to experiment, create, and learn. Makerspaces have evolved from the Do-It-Yourself movement which includes crafting, woodworking, etc. (Fisher, 2012). Academic libraries, such as Thompson Rivers University Library in British Columbia, have even adopted Lego into makerspaces to help relieve stress during exam periods and persuade patrons to build and experiment (TRULibrary, 2014).

A common thread through all of the literature reviewed was that providing 3D printing in libraries of any kind opens many opportunities for teaching, research, exploration, and experimentation (Scalfani and Sahib, 2013). Libraries have always been the perfect environment for creativity and innovation and thus provide the perfect setting for new technologies like 3D printing. There is no limit to what can be imagined and designed, allowing 3D printing to be useful across all disciplines (Colegrove, 2014).

University of Regina

The University of Regina's main campus is located in the capital city of Regina, Saskatchewan, Canada. Enrollment is more than 14,200 full-time and part-time students and there are more than 2,200 teaching staff. The University of Regina currently has ten faculties and 25 academic departments with programs leading to bachelor's, master's, and doctoral degrees. The University of Regina also works closely with its three federated colleges: First Nations University of Canada, Champion College, and Luther College.

The University of Regina Library (Archer Library) is the main library on campus. The Archer Library shares resources and the library catalogue with the libraries at Champion College, Luther College, Teaching Preparation Centre Library (children's literature and teaching materials), and First Nations University.

Funding and costs

3D printers range in price from \$300 to \$100,000, depending on the type of printing that you would like to be able to do in our library. The plastic filament FDM printers typically range between \$300 and \$3,000. Our library funded the printer and supplies, and fees collected from print jobs cover the ongoing costs such as filament spindles, build plate tape, and smart extruder parts. Filament spindles are roles of PLA plastic which come in strands that are wrapped around the spoil. PLA filament (around \$50.00 per spoil) comes in a variety of different colors and transparencies. The build plate is covered with a piece of sticky painter's tape (\$10.00 for ten sheets) which not only protects the plate from the hot printing nozzle, but also helps the melted plastic adhere to the plate, preventing slipping during the print process. The smart extruder is the small device that attaches to the printer via magnets and melts and extrudes the plastic in the appropriate pattern. The nozzle of the smart extruder can be removed and replaced if needed as can the entire smart extruder. The smart extruder provides approximately 1,000 hours of use and replacements cost about \$200.00. The ongoing costs are relatively inexpensive and the charges for printing cover the filament and machine wear and tear, which is used to replace the items listed above. Below is an image of the parts described from the MakerBot fifth generation

3D printing manual. The MakerBot 3D printer can print objects as large as 9.59 long \times 7.53 wide \times 5.29 high inches or 456 cubic inches (MakerBot, 2015). The overall size of an object is limited to the size of the build plate. Larger models can be designed in parts which can later be assembled. The MakerBot fifth generation can only print with one filament color at a time. There are some 3D printers that have dual nozzles which can extrude two colors during a print job. In order to print with different colors with a single nozzle the object would have to be printed in parts, exchanging the filament after each section is printed. The Library chose to go with a single nozzle printer because reviews showed that the single nozzle did not cause as many errors to occur while printing. If the Library purchases a second printer in the future we will consider a printer with dual print nozzles which would allow students to print with two colors simultaneously (Figure 1).

If funding through the library is problematic another option would be to search for donor possibilities (Gonzalez and Bennett, 2014). Departments and faculties on campus may donate funding to support the project, especially if they can see a direct benefit or use for their students and instructors. Support may also help to purchase additional items for the 3D printer such as 3D scanners, which allows objects to be scanned, replicated, and printed by the 3D printer.

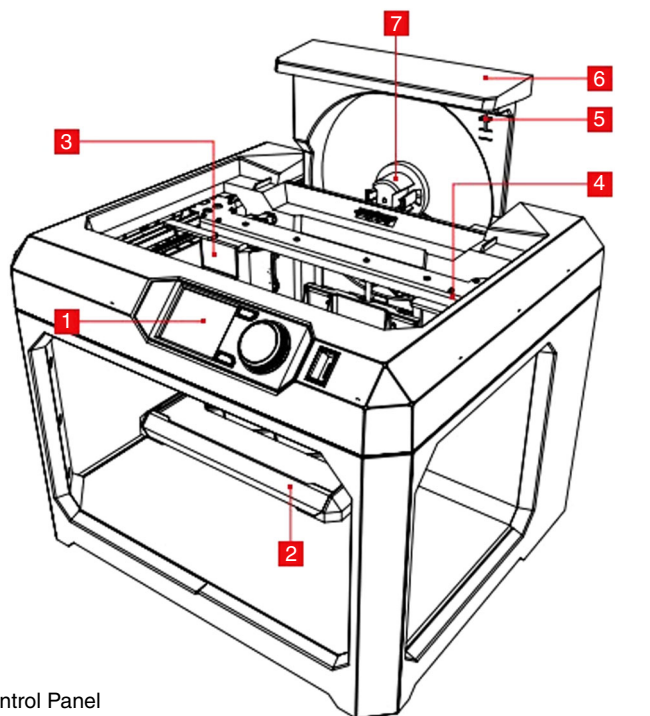

1. Control Panel

2. Build Plate

4. Gantry

6. Filament Drawer

3. Extruder Assembly

5. Filament Guide Tube

7. Filament Spindle

Source: MakerBot (2015)

Figure 1.
Diagram for
Makerbot replicator

Pilot project

Our pilot project ran from February to April 2015, and provided an opportunity for library staff to test out the pre-planned methods put in place to process print requests. During this time only a select few designs could be picked for printing. These pre-selected designs made the pilot straight forward and ensured the designs were well constructed, eliminating other variables during the test period. The designs that were chosen also demonstrated the printer's capabilities to students with the intention of generating other ideas of what could be created. Our sample designs included a linked chain, stretchy bracelet, snap-in gear keychain, nut and bolt, and an octopus tentacle smart phone stand. These items showed that creations could contain multiple moving parts, linked parts, and designs that give or flex. During this phase we also took on our first outside request from the University's student union. This campus group designed keepsake coins for Shinerama, which is a popular charitable cystic fibrosis fundraiser event in Canada. This was great practice for us as we had numerous back and forth conversations about the designs and some trial and error with printing this object.

The pilot period was also an opportunity for training two additional library staff that would be able to start prints and approve print requests. Training was done at various times throughout the pilot and included operational information (loading filament, starting prints), fixing common errors like filament jams and homing errors, and approving prints based on our policy and the quality of the print. The approval of prints is necessary in order to improve the rate of success. Prints with large overhangs or designs with many slices may not print well (Moorefield-Lang, 2014b). If this is the case then the individual will be alerted to these issues and asked to consider redesign. Prints that do not follow our policy due to inappropriate objects or copyrighted objects can be filtered at this point as well.

Instructional sessions

For individuals who are not familiar with designing objects for 3D printers there is a fairly steep learning curve. There are a variety of open repositories such as Thingiverse, where students can download predesigned objects to print without any knowledge about 3D design software, but in order to create designs from scratch some training is needed. There is a variety of different open source 3D design software available including Google SketchUp, Solid Edge, Blender, etc.

The Library partnered with the University's Centre for Teaching and Learning to offer a series of sessions on using software like Google SketchUp and Solid Edge as well as general sessions on how 3D printing works and what makes a good design. The Library contacted professors in Computer Science and Engineering who had experience with 3D modeling to conduct workshops for individuals wanting to create their own objects for printing. These instructors also had familiarity with 3D printers and were able to explain how to design a 3D model that would print successfully and how to avoid common errors when developing models.

3D printing policy

Creating a policy for printing was very helpful as it provided guidelines for what could be printed, who could print, as well as health and safety information. Our web page contains the 3D printing request form as well as a list of FAQs, including limitations of the printer, quality of prints, time it takes to print, how to pay for print jobs, etc.

3D printing at the Library is only open to faculty, students, and staff. Currently we do not accept print requests from the outside community. This is mostly due to the current demand and wait time for prints at the Library. As we begin to assess the demand we will consider opening it up to the public. The pricing for printing materials is also outlined in the policy document. Printing costs are calculated by weight; ten grams of filament costs one dollar, which covers the cost of the material, and also machine wear and tear. When the model is uploaded to the MakerBot software it will calculate the final weight of the object before printing. We use a simple formula to determine the cost of the filament used and then times that by two which not only provides cost recovery for the filament being used but also provides funding for new smart extruders and build tape. The formula for cost was developed by using the total weight of the filament spoil (990 grams) divided by the cost of the filament spoil (\$55.00) which equals the cost per gram which is \$0.06. Once the MakerBot provides the final weight of the model, this is multiplied by \$0.06 to determine the cost of the filament being used. For example, a 8.5 gram model would cost \$0.51 in filament (8.5 multiplied by 0.06). As mentioned, we double that cost, which allows us to save for future repairs to the machine, so the final cost for the object would be \$1.02, a reasonable price for patrons.

A very important aspect of the policy is what is permitted to be printed. The document states that there is to be no printing of weapons, obscene materials, and other materials that violate the security, health, and safety of others at the University. Patrons are also responsible to ensure that they are following Canadian Copyright Law when printing logos or pre-existing designs from 3D repositories such as Thingiverse. Patrons are also responsible for their designs and the success of the print job based on the quality of the design. If the print job fails due to poor design, then the patron is still responsible for the payment. If the print fails due to printer error, we will reprint at no additional cost.

Health and safety was investigated in great detail. The Health and Safety unit on campus looked into any fumes that would be emitted by the printer as well as heat given off by the machine. Because our printer uses PLA plastic there are no toxic fumes or smells while printing so no ventilation was required. The machine's print nozzle does maintain high temperatures when in operation so it was recommended that signage be placed near the printer alerting patrons that they should not touch the machine and that they should use caution so that loose clothing and hair does not get caught in moving parts. The policy details the potential hazards if individuals touch or interact with the machine. Currently only trained library staff members work with the printer so the chance of patrons injuring themselves on the machine is very low.

Best practices and common issues

Although 3D printing has been around for over 30 years, the machines still encounter errors and they are not at a point where every print will be a success. Many fixes for common issues have been discovered through trial and error, but the large online community of printer users also provides excellent support. You Tube and blogs have a wealth of information regarding repairs, printing errors, and print setup. During the pilot project at the University of Regina Library, we documented and created solutions for some commonly experienced issues and errors.

One of the most common issues encountered by our machine is what is known as filament jams. Usually the printer shows an error message if there is a filament jam, which sometimes results in the printer failing to extrude any plastic but continuing to

move through the pattern without stopping. Typically this indicates that there is some sort of filament jam in the extruder. There are several approaches to unclogging the extruder when there is a filament jam. Our staff, experimenting during the pilot period, found that unloading and reloading the filament usually allowed printing to resume. Sometimes reloading required pushing the filament down into the smart extruder to clear a blockage. In difficult cases the smart extruder would actually be opened up to manually remove the clog with small tools. The parts of the smart extruder that do not contain electronic or material that will absorb liquids can be bathed in acetone, which will remove any excess plastic. Sometimes the filament strands in the spoil can get tangled and the extruder cannot pull plastic into the device. If this happens, unload the filament from the machine and unravel the spoil until the tangle is out.

Another indication of how filament is being jammed can be seeing a marked or burned build plate. This can happen if the build plate is too close to the nozzle head, making it difficult for plastic to flow through the extruder. One solution is to level the building plate, which can be done under the utilities option on the printer's digital panel. Another option is to reduce the z-axis, which can be done by going to device preferences in the MakerBot software that connects to the printer.

There can be a number of reasons for failed prints. Sometimes it is due to the reasons above, but at times it can be unclear. If the design of the 3D object is poor then the object will not print well or the print might fail to complete. Another consideration is the need for supports and/or rafts. When supports are turned on, areas that overhang on the object being printed are supported with plastic that can be popped off after the print is completed. Rafts are usually recommended because they help the object stick to the build plate and not come loose in the printing process. Rafts can also be removed from the object once the print is complete.

The printer should be in a location that is not drafty, which could affect the printing quality as the temperature must remain consistent. The printer should also be in a location where it is not likely to get bumped or knocked, interrupting the printing nozzle, or throwing off the alignment (Gonzalez and Bennett, 2014). Keeping the printer in a good environment will help to reduce the number of failed prints.

Plans for the future

Because of the popularity of 3D printing in the Library, we are looking toward purchasing more 3D printers to keep up with demand as well as expanding our makerspace to include other types of experimental and creative technologies and objects. We are currently looking into starting a Lego table, which was inspired by the project at the Thompson Rivers University Library. These types of projects would be available to students during high-stress periods (midterms, finals).

We would also like to investigate further information sessions that would teach patrons how to operate the 3D printer so they could book time with the printer. This would allow individuals to use the machine directly and gain more experience with the technology. This idea came from the University of Toronto Libraries, where they offer training and certification in operating 3D printers. Once certified, patrons can then book time with the printer (University of Toronto Libraries, 2015).

Conclusion

Libraries have always been leaders and innovators, and offering 3D printing technology is just another step forward in that direction. 3D printers are relatively cheap and an easy way to interact with the community the library serves.

“Libraries provide resources for not only consuming information, but also for generating new information and research” (Pryor, 2014, p. 2), which is at the heart of any academic institution. Makerspaces and 3D printing provide the perfect opportunity for the generation of new knowledge.

References

- Colegrove, P. (2014), “Making it real: 3D printing as a library service”, available at: www.educause.edu/ero/article/making-it-real-3d-printing-library-service (accessed April 24, 2015).
- Fisher, E. (2012), “Makerspaces move into academic libraries”, ACRL TechConnect, available at: <http://acrl.lala.org/techconnect/?p=2340> (accessed April 28, 2015).
- Gonzalez, S.R. and Bennett, D.B. (2014), “Planning and implementing a 3D printing service in an academic library”, *Issues in Science and Technology Librarianship*, No. 78, pp. 1-14. doi: 10.5062/F4M043CC, available at: www.isrl.org/previous.html
- Groenendyk, M. and Gallant, R. (2013), “3D printing and scanning at the Dalhousie University Libraries: a pilot project”, *Library Hi Tech*, Vol. 31 No. 1, pp. 34-41.
- Jamaluddin, A. (2013), “10 things you need to know before buying a 3D printer”, available at: www.hongkiat.com/blog/things-know-buying-3d-printer/ (accessed April 28, 2015).
- Kurt, L. and Colegrove, T. (2012), “3D printers in the library: toward a fablab in the academic library”, available at: <http://acrl.lala.org/techconnect/?p=1403> (accessed April 20, 2015).
- MakerBot (2015), “MakerBot replicator user manual”, available at: http://download.makerbot.com/replicator/MB_Replicator_UserManual.pdf (accessed May 5, 2015).
- Moorefield-Lang, H.M. (2014a), “3-D printing in your libraries and classrooms”, *Technology Guest Column*, Vol. 43 No. 1, pp. 70-72.
- Moorefield-Lang, H.M. (2014b), “Makers in the library: case studies of 3D printers and maker spaces in library settings”, *Library Hi Tech*, Vol. 32 No. 4, pp. 583-593.
- Pryor, S. (2014), “Implementing a 3D printing service in an academic library”, *Journal of Library Administration*, Vol. 51 No. 1, pp. 1-10.
- Scalfani, V.F. and Sahib, J. (2013), “A model for managing 3D printing services in academic libraries”, *Issues in Science and Technology Librarianship*, Vol. 72, Spring, pp. 1-13. doi: 10.5062/F4M043CC, available at: www.isrl.org/previous.html
- TRUlibrary (2014), “Fighting stress with dogs and lego”, available at: <http://librarynews.inside.tru.ca/2014/11/21/fighting-stress-with-dogs-and-lego-stress-free-zone-sfz/> (accessed April 29, 2015).
- University of Toronto Libraries (2015), “3D Printing @ Gerstein + MADLab”, available at: <http://guides.library.utoronto.ca/content.php?pid=620064&sid=5212516> (accessed April 29, 2015).

Corresponding author

Gillian Andrea Nowlan can be contacted at: gillian.nowlan@uregina.ca

For instructions on how to order reprints of this article, please visit our website:

www.emeraldgroupublishing.com/licensing/reprints.htm

Or contact us for further details: permissions@emeraldinsight.com

This article has been cited by:

1. Thomas K. Finley. 2016. The Impact of 3D Printing Services on Library Stakeholders: A Case Study. *Public Services Quarterly* 12:2, 152-163. [[CrossRef](#)]