

Passivity and complementarity

M. K. Camlibel · L. Iannelli · F. Vasca

Received: 31 December 2006 / Accepted: 6 March 2013 / Published online: 16 April 2013
© Springer-Verlag Berlin Heidelberg and Mathematical Optimization Society 2013

Abstract This paper studies the interaction between the notions of passivity of systems theory and complementarity of mathematical programming in the context of complementarity systems. These systems consist of a dynamical system (given in the form of state space representation) and complementarity relations. We study existence, uniqueness, and nature of solutions for this system class under a passivity assumption on the dynamical part. A complete characterization of the initial states and the inputs for which a solution exists is given. These initial states are called consistent states. For the inconsistent states, we introduce a solution concept in the framework of distributions.

Mathematics Subject Classification 34A12 · 90C33 · 90C90 · 93C05 · 93D10

1 Introduction

Complementarity theory is one of the extensively explored areas of mathematical programming (see the excellent survey of [17]). The classical complementarity

M. K. Camlibel (✉)
Department of Mathematics, University of Groningen, P.O. Box 800,
9700 AV Groningen, The Netherlands
e-mail: m.k.camlibel@rug.nl

M. K. Camlibel
Department of Electronics and Communication Engineering,
Dogus University, Acibadem, 34722 Kadikoy, Istanbul, Turkey

L. Iannelli · F. Vasca
Dipartimento di Ingegneria, Università del Sannio,
Piazza Roma 21, 82100 Benevento, Italy
e-mail: luigi.iannelli@unisannio.it

F. Vasca
e-mail: vasca@unisannio.it

problem has two main actors: two variables that satisfy the so-called complementarity conditions and that are related through an algebraic relation. In various areas of engineering as well as operations research, however, one encounters mathematical models (see e.g. [33,41] for an account of examples) in which complementarity conditions are accompanied with differential-algebraic relations instead of purely algebraic. Looking with systems theory glasses, we call such models *complementarity systems*.

Specific examples of complementarity systems have already been studied in many different fields. In particular, mechanics deserves to be mentioned with its vast literature on models employing complementarity methods extensively. A systematic study of system-theoretical properties of complementarity systems, however, was initiated by papers [39,40]. Since then, related research has been growing in many directions. To give a quick (and inevitably incomplete) overview of the numerous works (see the surveys [1,20]), we mention [2,8,13,19,22,24] for well-posedness, [35] for nature of solutions, [10] for modelling issues, [22] for simulation, [4] for equivalent classes, [3,9,11,12] for controllability, [14] for stabilizability, [15] for observability, and [16] for stability. Also the works [18,30,31,36] on differential variational inequalities and [2] on stability of monotone multivalued mappings are closely related to this line of research.

Besides complementarity, the notion of passivity is among main ingredients of this paper. Having its roots in circuit theory, passivity has always been a central concept in systems theory. Passive systems satisfy an abstract energy balance inequality: the stored energy at a time instant cannot exceed the sum of the stored energy at a previous time instant and the energy supplied to the system between these two time instants. Such a conceptualization of passivity was first introduced by Willems [42]. A detailed account on passivity and related notions in systems and control can be found in [6].

The current paper deals with the complementarity systems for which the underlying dynamical system is linear and passive. We study existence, uniqueness, and nature of solutions for this class. These were already the subject of previous work [10,13,21,22]. However, all these references make a number of simplifying assumptions that do not hold in many practical applications. Without these assumptions, the line of thought of [10,13,21,22] breaks down in an irreparable way. By developing a completely different line of argumentation, this paper gives a full characterization of existence and uniqueness issues for linear passive complementarity systems.

The structure of the paper is as follows. In the next section, we introduce notational conventions. A brief review of the linear complementarity problem and linear passive systems is also given. Section 3 introduces cone complementarity systems and gives a detailed account on already available literature. It also discusses the restrictiveness of the earlier assumptions and illustrates, by means of examples, that some of these assumptions do not hold in various practical problems. The main results are presented in Sect. 4. The paper closes with the conclusions in Sect. 5. Some very basic facts of quadratic programming and geometric control theory are included in Appendix 1 and 2 for the sake of completeness.

2 Preliminaries

The two main ingredients of this paper are the linear complementarity problem of mathematical programming and the passivity concept of systems theory. For the sake of

completeness, these notions will be reviewed in what follows. We begin with notational conventions.

2.1 Notation

Sets, vectors, and matrices.

The set of real numbers is denoted by \mathbb{R} , nonnegative real numbers by \mathbb{R}_+ , and complex numbers by \mathbb{C} .

Let x be a complex vector. Its transpose is denoted by x^T and its conjugate transpose by x^* . The same notations are used also for matrices. We write $x \perp y$ if $x^T y = 0$.

Let x be an n -vector and $\alpha \subseteq \{1, 2, \dots, n\}$ be an index set. The vector x_α denotes the components of x indexed by α .

Let M be a matrix. Its image is denoted by $\text{im } M = \{y \mid y = Mx \text{ for some } x\}$ and its kernel by $\text{ker } M = \{x \mid Mx = 0\}$. A square matrix M , not necessarily symmetric, is called nonnegative definite if $x^T Mx \geq 0$ for all x . It is called positive definite if it is nonnegative definite and $x^T Mx = 0$ implies that $x = 0$.

Sometimes, we do not indicate the dimensions of vectors and matrices explicitly. In such cases, their dimensions are such that all the expressions that they appear make sense.

Inequalities.

All inequalities involving a vector are understood componentwise. We say that a sequence of real numbers is lexicographically nonnegative if all elements are zero or the first nonzero element is positive. A sequence of real vectors (x^1, x^2, \dots) is lexicographically nonnegative if the real number sequences (x_i^1, x_i^2, \dots) is lexicographically nonnegative for all possible indices i . To denote a lexicographically nonnegative sequence (x^1, x^2, \dots) , we write $(x^1, x^2, \dots) \succcurlyeq 0$.

Cones and dual cones.

A set is called a cone if any nonnegative multiple of each element belongs to it. A set \mathcal{S} is called polyhedral if $\mathcal{S} = \{x \mid Ax \geq b\}$ for a matrix A and a vector b . The notation $\text{pos}(M)$, where M is a matrix, denotes the cone $\{Mx \mid x \geq 0\}$.

For a non-empty set \mathcal{S} , not necessarily a cone, we define its dual cone as $\{x \mid x^T y \geq 0 \text{ for all } y \in \mathcal{S}\}$ and denote this set by \mathcal{S}^* .

Functions.

Let $f : \mathbb{R} \rightarrow \mathbb{R}^n$ be a function. We write $f(t) \equiv 0$ meaning that $f(t) = 0$ for all t . When it exists, its i th derivative is denoted by $f^{(i)}$. Sometimes, we write \dot{f} for its first derivative. The left limit of f at a point T is denoted by $\lim_{t \uparrow T} f(t)$.

The Laplace transform of a vector-valued function f is denoted by $\hat{f}(s)$.

The exponential function of a matrix M is denoted by $t \mapsto \exp(Mt)$, i.e. $\exp(Mt) = \sum_{i=0}^{\infty} M^i t^i / i!$.

The notation $O(x) : \mathbb{R} \mapsto \mathbb{R}$ denotes a function for which there exist a positive real number c and a real number \bar{x} such that $O(x) \leq cx$ for all $x \geq \bar{x}$.

Rational functions.

Let f be a rational function, i.e. $f = p/q$ for some polynomials p and q . We say that f is a rational function with a degree n when the difference between the degrees of p and q equals to n . When the degree of p is less than or equal to that of q , we say that f is proper. When the degree of p is less than that of q , f is said to be strictly proper. Note that the degree of a proper rational function is always nonpositive and that of a strictly proper rational function is always negative.

We say $f(\sigma) \geq 0$ for all sufficiently large real numbers σ meaning that there exists a real number $\bar{\sigma}$ such that $f(\sigma) \geq 0$ whenever $\sigma \geq \bar{\sigma}$.

System-theoretical notions.

Consider a linear state-space system

$$\dot{x}(t) = Ax(t) + Bz(t) \quad (1a)$$

$$w(t) = Cx(t) + Dz(t) \quad (1b)$$

where the state x takes values from \mathbb{R}^n and the external variables (z, w) from $\mathbb{R}^m \times \mathbb{R}^p$. We define the controllable subspace $\text{im } B + \text{im } AB + \dots + \text{im } A^{n-1}B$. If this subspace is the entire \mathbb{R}^n , we say that the system (1) (or (A, B)) is controllable. We define the unobservable subspace as $\ker C \cap \ker CA \cap \dots \cap \ker CA^{n-1}$. When this subspace consists of only the zero vector, we say that the system (1) (or (C, A)) is observable. When the system (or (A, B, C)) is both controllable and observable, it is called minimal.

Associated to such a system, we define the transfer matrix as the complex-valued rational function $s \mapsto D + C(sI - A)^{-1}B$.

2.2 Linear complementarity problem

Given an m -vector q and an $m \times m$ matrix M , the linear complementarity problem $\text{LCP}(q, M)$ is to find an m -vector z such that

$$z \geq 0 \quad (2a)$$

$$q + Mz \geq 0 \quad (2b)$$

$$z^T(q + Mz) = 0. \quad (2c)$$

If such a vector z exists, we say that z solves (is a solution of) $\text{LCP}(q, M)$. We say that the $\text{LCP}(q, M)$ is feasible if there exists z satisfying (2a) and (2b).

The LCP is a well-studied subject of mathematical programming [17]. For the sake of completeness, we quote the following two theorems. The first one can be considered as the *fundamental theorem* of the LCP theory. It states necessary and sufficient conditions for the unique solvability of the LCP for all vectors q .

Theorem 1 (Theorem 3.3.7 of [17]) *The LCP(q, M) has a unique solution for all q if, and only if, all the principal minors of the matrix M are positive.*

Matrices with the above-mentioned property are known as P -matrices. It is well-known that every positive definite matrix is in this class. Besides positive definite matrices, the nonnegative definite matrices will appear in the LCP context in the sequel. If the M matrix is nonnegative definite then the LCP does not necessarily have solutions for all vectors q . For example, the LCP($q, 0$) admits solutions only if $q \geq 0$.

In the rest of the paper, we will often refer to the solution set of LCP($0, M$) which will be denoted by

$$\mathcal{Q}_M = \{z \mid z \geq 0, Mz \geq 0, \text{ and } z^T Mz = 0\}. \tag{3}$$

The following theorem characterizes the conditions under which an LCP with a non-negative definite matrix M has solutions.

Theorem 2 (Cor. 3.8.10 of [17]) *Let M be a nonnegative definite matrix. Then, the following statements are equivalent.*

1. $q \in \mathcal{Q}_M^*$.
2. LCP(q, M) is feasible.
3. LCP(q, M) is solvable.

When M is (not necessarily symmetric) a nonnegative definite matrix, the set \mathcal{Q}_M is a convex cone and can be given by $\mathcal{Q}_M = \{z \mid z \geq 0 \text{ and } (M + M^T)z = 0\}$.

2.3 Linear passive systems

Having roots in circuit theory, passivity is a concept that has always played a central role in systems theory. A system is passive if for any time interval the difference between the stored energy at the end of the interval and at the beginning is less than or equal to the supplied energy during the interval.

Definition 1 [42] A linear system $\Sigma(A, B, C, D)$ given by

$$\dot{x}(t) = Ax(t) + Bz(t) \tag{4a}$$

$$w(t) = Cx(t) + Dz(t) \tag{4b}$$

is called *passive* if there exists a nonnegative function $V : \mathbb{R}^n \rightarrow \mathbb{R}_+$ such that for all $t_0 \leq t_1$ and all trajectories (z, x, w) of the system (4) the following inequality holds:

$$V(x(t_0)) + \int_{t_0}^{t_1} z^T(t)w(t) dt \geq V(x(t_1)). \tag{5}$$

If it exists the function V is called a *storage function*.

Passivity property can be characterized in terms of the state space representation or the transfer matrix of the system as follows.

Proposition 1 Consider the following statements:

1. The system $\Sigma(A, B, C, D)$ is passive
2. The linear matrix inequalities

$$K = K^T \geq 0 \quad \text{and} \quad \begin{bmatrix} A^T K + K A & K B - C^T \\ B^T K - C & -(D + D^T) \end{bmatrix} \leq 0 \tag{6}$$

have a solution K .

3. The function $V(x) = \frac{1}{2}x^T Kx$ defines a storage function.
4. The transfer matrix $G(s) = D + C(sI - A)^{-1}B$ is positive real, i.e., $u^*[G(\lambda) + G^*(\lambda)]u \geq 0$ for all complex vectors u and all complex numbers λ such that $\text{Re}(\lambda) > 0$ and λ is not an eigenvalue of A .
5. The triple (A, B, C) is minimal.
6. The pair (C, A) is observable.
7. The matrix K is positive definite.

The following implications hold:

- i. $1 \Leftrightarrow 2 \Leftrightarrow 3$.
- ii. $2 \Rightarrow 4$.
- iii. $4 \text{ and } 5 \Rightarrow 2$.
- iv. $2 \text{ and } 6 \Rightarrow 7$.

Proof The implications i, ii and iii are consequences of the well-known Kalman-Yakubovich-Popov lemma (see e.g. [6]). To see that the implication iv holds, let \bar{x} be such that $\bar{x}^T K \bar{x} = 0$. Since K is symmetric and nonnegative definite, we get $K \bar{x} = 0$. Note that $\bar{x}^T (A^T K + K A) \bar{x} = 0$. Since $-(A^T K + K A)$ is symmetric and, due to the LMI (6), nonnegative definite, we get $(A^T K + K A) \bar{x} = K A \bar{x} = 0$. This means that $A \ker K \subseteq \ker K$, i.e. $\ker K$ is an A -invariant subspace. Note also that passivity implies that

$$\begin{bmatrix} \bar{x} \\ \alpha u \end{bmatrix}^T \begin{bmatrix} A^T K + K A & K B - C^T \\ B^T K - C & -(D + D^T) \end{bmatrix} \begin{bmatrix} \bar{x} \\ \alpha u \end{bmatrix} = -2\alpha u^T C \bar{x} - \alpha^2 u^T (D + D^T) u \leq 0. \tag{7}$$

for all α and u . If $C \bar{x} \neq 0$, one can choose α and u such that this inequality is violated. Therefore, $C \bar{x} = 0$. This means that $\ker K \subseteq \ker C$. As the unobservability subspace $\ker C \cap \ker CA \cap \dots \cap \ker CA^{n-1}$ is the largest A -invariant subspace that is contained in $\ker C$, we get $\ker K \subseteq \ker C \cap \ker CA \cap \dots \cap \ker CA^{n-1}$. Since the system is observable, the right hand of this inclusion is the trivial subspace $\{0\}$, hence K is positive definite. \square

Passivity imposes a strong structure on the system. The following lemma collects some of the consequences of passivity that will be used often in the paper.

Lemma 1 Suppose that the system $\Sigma(A, B, C, D)$ is passive. Let K be any solution to the LMIs (6) and let $G(s) = D + C(sI - A)^{-1}B$. Then, the following statements hold.

- i. D is nonnegative definite.
- ii. $\bar{u}^T(D + D^T)\bar{u} = 0 \Rightarrow C^T\bar{u} = K B\bar{u}$.
- iii. $\ker \begin{bmatrix} C^T \\ D + D^T \end{bmatrix} = \ker \begin{bmatrix} K B \\ D + D^T \end{bmatrix}$.
- iv. $\bar{u}^T(D + D^T)\bar{u} = 0 \Rightarrow \bar{u}^T C B\bar{u} = \bar{u}^T B^T K B\bar{u} \geq 0$.
- v. $\bar{x}^T(A^T K + K A)\bar{x} = 0 \Rightarrow C\bar{x} = B^T K\bar{x}$.
- vi. $A \ker K \subseteq \ker K$.
- vii. $\ker K \subseteq \ker C \cap \ker C A \cap \dots \cap \ker C A^{n-1}$.
- viii. $\bar{u} \in \ker K B \Rightarrow G(s)\bar{u} = D\bar{u}$ for all complex numbers s .
- ix. $\ker [G(\sigma) + G^T(\sigma)] = \ker \begin{bmatrix} K B \\ D + D^T \end{bmatrix}$ for all real positive numbers σ that are not eigenvalues of A .

Proof i. This immediately follows from the LMIs (6).
 ii. Let \bar{u} be such that $\bar{u}^T(D + D^T)\bar{u} = 0$. Note that

$$0 \geq \begin{bmatrix} \bar{x} \\ \alpha\bar{u} \end{bmatrix}^T \begin{bmatrix} A^T K + K A & K B - C^T \\ B^T K - C & -(D + D^T) \end{bmatrix} \begin{bmatrix} \bar{x} \\ \alpha\bar{u} \end{bmatrix} = \bar{x}^T(A^T K + K A)\bar{x} + 2\alpha\bar{x}^T(K B - C^T)\bar{u}. \tag{8}$$

Since α and \bar{x} are arbitrary, the right hand side can be made positive unless $(K B - C^T)\bar{u} = 0$.

iii–iv. These assertions readily follow from ii.

v. Let \bar{x} be such that $\bar{x}^T(A^T K + K A)\bar{x} = 0$. Note that

$$0 \geq \begin{bmatrix} \bar{x} \\ \alpha\bar{u} \end{bmatrix}^T \begin{bmatrix} A^T K + K A & K B - C^T \\ B^T K - C & -(D + D^T) \end{bmatrix} \begin{bmatrix} \bar{x} \\ \alpha\bar{u} \end{bmatrix} = 2\alpha\bar{x}^T(K B - C^T)\bar{u} + \bar{u}^T(D + D^T)\bar{u}. \tag{9}$$

Since α and \bar{u} are arbitrary, the right hand side can be made positive unless $\bar{x}^T(K B - C^T) = 0$.

vi and vii. See the proof of the implication iv of Proposition 1.

viii. If $\bar{u} \in \ker K B$ then $B\bar{u}$ must belong to $\ker K$ which is contained in the unobservability subspace $\ker C \cap \ker C A \cap \dots \cap \ker C A^{n-1}$. This means that $C(sI - A)^{-1}B\bar{u} \equiv 0$.

ix. Let σ be a real positive number that is not an eigenvalue of A .

Let \bar{u} be such that $K B\bar{u} = 0$ and $(D + D^T)\bar{u} = 0$. Due to viii, one has $\bar{u}^T[G(\sigma) + G^T(\sigma)]\bar{u} = 0$. Since $G(s)$ is positive real, one gets $[G(\sigma) + G^T(\sigma)]\bar{u} = 0$. This means that

$$\ker[G(\sigma) + G^T(\sigma)] \supseteq \ker \begin{bmatrix} K B \\ D + D^T \end{bmatrix}. \tag{10}$$

To show the reverse inclusion, let $\bar{u} \in \ker[G(\sigma) + G^T(\sigma)]$ and define $\bar{x} = (\sigma I - A)^{-1}B\bar{u}$. Note that

$$A\bar{x} + B\bar{u} = \sigma\bar{x} \tag{11}$$

and

$$\begin{aligned} \begin{bmatrix} \bar{x} \\ \bar{u} \end{bmatrix}^T \begin{bmatrix} A^T K + KA & KB - C^T \\ B^T K - C & -(D + D^T) \end{bmatrix} \begin{bmatrix} \bar{x} \\ \bar{u} \end{bmatrix} \\ = (A\bar{x} + B\bar{u})^T K\bar{x} + \bar{x}^T K(A\bar{x} + B\bar{u}) - \bar{u}^T [G(\sigma) + G^T(\sigma)]\bar{u} \end{aligned} \tag{12}$$

$$\stackrel{(11)}{=} 2\sigma\bar{x}^T K\bar{x}. \tag{13}$$

The LMIs (6) imply that $\bar{x}^T K\bar{x} = 0$. Since K is nonnegative definite, $K\bar{x} = 0$. It follows from (11) and vi that $KB\bar{u} = 0$. Note that

$$0 = \bar{u}^T [G(\sigma) + G^T(\sigma)]\bar{u} \tag{14}$$

$$= \bar{u}^T (D + D^T)\bar{u} \tag{15}$$

due to viii. Consequently,

$$\ker [G(\sigma) + G^T(\sigma)] \subseteq \ker \begin{bmatrix} KB \\ D + D^T \end{bmatrix}. \tag{16}$$

□

The following lemma will serve as a bridge between the complementarity methods and passive systems.

Lemma 2 *Suppose that the system $\Sigma(A, B, C, D)$ is passive. Let $G(s) = D + C(sI - A)^{-1}B$. Then, $\mathcal{Q}_{G(\sigma)}^* = \mathcal{Q}_D^* + \text{im } C$ for all positive numbers σ not being an eigenvalue of A .*

Proof We begin by claiming that

$$\mathcal{Q}_{G(\sigma)} = \mathcal{Q}_D \cap \ker C^T. \tag{17}$$

To see this, let $\bar{u} \in \mathcal{Q}_{G(\sigma)}$ for some positive real number σ not being an eigenvalue of A . This means that

$$0 \leq \bar{u} \perp G(\sigma)\bar{u} \geq 0. \tag{18a}$$

Passivity implies nonnegative definiteness of $G(\sigma)$ due to Proposition 1. Then, it follows from (18) that $\bar{u} \in \ker[G(\sigma) + G^T(\sigma)]$. Lemma 1 ix and viii yield that $G(\sigma)\bar{u} = D\bar{u}$. This, together with (18), means that $\bar{u} \in \mathcal{Q}_D$. By Lemma 1 ix and iii, we have already $\bar{u} \in \ker C^T$. Thus, we get $\mathcal{Q}_{G(\sigma)} \subseteq \mathcal{Q}_D \cap \ker C^T$. To see that the reverse inclusion holds, let $\bar{u} \in \mathcal{Q}_D \cap \ker C^T$. Hence,

$$\bar{u} \geq 0 \tag{19a}$$

$$D\bar{u} \geq 0 \tag{19b}$$

$$\bar{u}^T D\bar{u} = 0 \tag{19c}$$

$$C^T \bar{u} = 0. \tag{19d}$$

Since D is nonnegative definite due to Lemma 1 i, we get $\bar{u} \in \ker(D + D^T) \cap \ker C^T$. Lemma 1 iii and viii imply that $D\bar{u} = G(\sigma)\bar{u}$. This, together with (19), means that $\bar{u} \in \mathcal{Q}_{G(\sigma)}$. Therefore, $\mathcal{Q}_{G(\sigma)} \supseteq \mathcal{Q}_D \cap \ker C^T$. So far we proved the relation (17). At this point, we invoke two basic facts about closed convex cones:

1. $(\mathcal{X}^*)^* = \mathcal{X}$ if \mathcal{X} is a polyhedral cone (see [37, Theorem 2.7.7]).
2. $\mathcal{X}^* \cap \mathcal{Y}^* = (\mathcal{X} + \mathcal{Y})^*$ if \mathcal{X} and \mathcal{Y} are cones.

Applying these to (17), we get $\mathcal{Q}^*_{G(\sigma)} = \mathcal{Q}^*_D + \text{im } C$. □

3 Linear cone complementarity systems

Consider the system

$$\dot{x}(t) = Ax(t) + Bz(t) + Eu(t) \tag{20a}$$

$$w(t) = Cx(t) + Dz(t) + Fu(t) \tag{20b}$$

$$C \ni z(t) \perp w(t) \in \mathcal{C}^* \tag{20c}$$

where the state x takes values from \mathbb{R}^n , the input u from \mathbb{R}^k , the complementarity variables (z, w) from \mathbb{R}^{m+m} , and $\mathcal{C} \subseteq \mathbb{R}^m$ is a polyhedral cone. We call these systems *linear cone complementarity systems* and denote (20) by $\text{LCCS}(A, B, C, D, E, F)$. In case $\mathcal{C} = \mathbb{R}^m_+$, we get a linear complementarity system which is denoted by $\text{LCS}(A, B, C, D, E, F)$. When the sextuple (A, B, C, D, E, F) is clear from the context, we use only LCCS or LCS.

Well-posedness of LCCS (20) with a passive¹ quadruple (A, B, C, D) was studied by [10,22] without external inputs and, respectively, for the cases $\mathcal{C} = \mathbb{R}^m_+$ and \mathcal{C} is a Cartesian product of any combination of the cones $\{0\}$, \mathbb{R}_+ , and \mathbb{R} . The papers [13,21] generalize these results to the LCCS with external inputs. All these earlier works assume that

- A.1 The triple (A, B, C) is minimal, and
- A.2 the matrix $\text{col}(B, D + D^T)$ is of full column rank.

In this paper, we are interested in dropping these two assumptions which are hard to motivate from practical point of view. Next, we briefly discuss why these assumptions are restrictive.

The external variables z and w correspond to, respectively, inputs and outputs in the context of control theory. For control problems, controllability and observability

¹ See also [5,7] for ‘passive-like’ systems with the property that $KB = C^T$ for some positive definite matrix K .

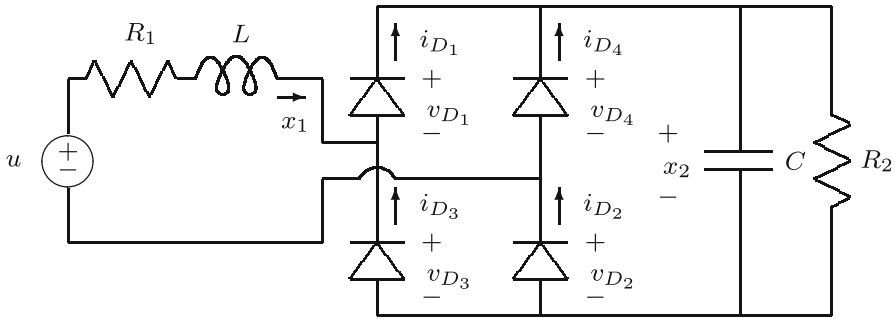

Fig. 1 Power converter diode bridge

are rather natural assumptions. Even further, weaker forms of these notions, called stabilizability and detectability (see e.g. [38] for more details), are necessary conditions for the most, if not all, control problems. However, the variables z and w play a completely different role in the context of complementarity systems. As such, it is hard to motivate controllability and/or observability assumptions in this context. Furthermore, minimality of the triple (A, B, C) is employed only to guarantee the positive definiteness of the storage function in the earlier papers [10, 13, 21, 22]. In this paper, we drop the assumption A.1 and work under the weaker assumption that the storage function is positive definite.

It turns out that the second assumption is even harder to motivate. In many practical problems, the number of complementarity pairs is greater than the number of states (i.e. $m > n$). As such, assumption A.2 cannot be met at all. Two of such examples are in order. The first one is from circuit theory.

Example 1 Consider the diode-bridge circuit depicted in Fig. 1.

By extracting the ideal diodes and using Kirchhoff laws, one can derive the governing circuit equations as

$$\begin{bmatrix} \dot{x}_1 \\ \dot{x}_2 \end{bmatrix} = \begin{bmatrix} -\frac{R_1}{L} & 0 \\ 0 & -\frac{1}{R_2 C} \end{bmatrix} \begin{bmatrix} x_1 \\ x_2 \end{bmatrix} + \begin{bmatrix} 0 & \frac{1}{L} & -\frac{1}{L} & 0 \\ \frac{1}{C} & 0 & 0 & \frac{1}{C} \end{bmatrix} \begin{bmatrix} i_{D_1} \\ v_{D_2} \\ v_{D_3} \\ i_{D_4} \end{bmatrix} + \begin{bmatrix} \frac{1}{L} \\ 0 \end{bmatrix} u \quad (21a)$$

$$\begin{bmatrix} v_{D_1} \\ i_{D_2} \\ i_{D_3} \\ v_{D_4} \end{bmatrix} = \begin{bmatrix} 0 & 1 \\ 1 & 0 \\ -1 & 0 \\ 0 & 1 \end{bmatrix} \begin{bmatrix} x_1 \\ x_2 \end{bmatrix} + \begin{bmatrix} 0 & 0 & -1 & 0 \\ 0 & 0 & 0 & 1 \\ 1 & 0 & 0 & 0 \\ 0 & -1 & 0 & 0 \end{bmatrix} \begin{bmatrix} i_{D_1} \\ v_{D_2} \\ v_{D_3} \\ i_{D_4} \end{bmatrix}. \quad (21b)$$

Here x_1 is the current through the inductor L , x_2 is the voltage across the capacitor C and (v_{D_i}, i_{D_i}) is the voltage-current pair associated to the i th diode. Characteristics of ideal diodes can be given in forms of complementarity conditions as

$$0 \leq v_{D_i} \perp i_{D_i} \geq 0 \quad \text{for all } i = 1, 2, 3, 4. \quad (21c)$$

In this way, we obtain a linear complementarity system of the form (20) where $C = \mathbb{R}_+^4$. Note that $D + D^T = 0$ and B is a matrix having more columns than rows. As such, the assumption A.2 cannot be met. It can be verified that a solution to the LMIs (6) is given by

$$K = \begin{bmatrix} L & 0 \\ 0 & C \end{bmatrix}. \tag{22}$$

The second example comes from optimization.

Example 2 Many models for network usage can be described in terms of users who have access to several resources. The use of a given resource generates a cost for the user, for instance in terms of incurred delay. This cost depends in general on the load that is placed in the resource by all users. Suppose that we have p users and n resources. Let $\ell_{i,j}(t)$ denote the load per unit of time placed by user i on resource j at time t , $q_{i,j}(t)$ denote the cost incurred at time t by user i when applying to resource j , $d_i(t)$ denote the total demand of user i at time t and $a_i(t)$ denote the cost accepted by user i at time t . Also let $L(t) \in \mathbb{R}^{p \times n}$ with $L_{ij}(t) = \ell_{i,j}(t)$ be the load matrix, $Q(t) \in \mathbb{R}^{p \times n}$ with $Q_{ij}(t) = q_{i,j}(t)$ be the cost matrix, $d(t) \in \mathbb{R}^p$ be the demand vector, and $a(t) \in \mathbb{R}^p$ be the accepted cost vector. Then, we have the total load relation

$$L(t)e_n = d(t) \tag{23}$$

where e_n is an n -vector such that all elements are equal to 1. Introduce a state vector $x(t) \in \mathbb{R}^n$ in terms of which the dynamics of the system is described and which moreover determines the cost matrix, for instance as follows:

$$\dot{x}(t) = L^T(t)e_p \tag{24a}$$

$$Q(t) = e_p(Kx(t))^T - a(t)(e_n)^T \tag{24b}$$

where $K \in \mathbb{R}^{n \times n}$ is a symmetric positive definite matrix. As a way to describe the behavior of users, assume that the Wardrop principle holds at every time instant t . This behavioral principle, together with the nonnegativity of the load, can be expressed in matrix terms by

$$0 \leq L(t) \perp Q(t) - a(t)(e_n)^T \geq 0 \tag{24c}$$

where the inequalities hold componentwise and the \perp relation is understood in the sense of the inner product $\langle X, Y \rangle = \text{tr}(X^T Y)$ where $X, Y \in \mathbb{R}^{p \times n}$. Denote the matrix $Q(t) - a(t)(e_n)^T$ by $\bar{Q}(t)$.

Now, define

$$z(t) = \text{col}((L_{1\bullet}(t))^T, (L_{2\bullet}(t))^T, \dots, (L_{p\bullet}(t))^T, a(t)) \tag{25}$$

$$w(t) = \text{col}((\bar{Q}_{1\bullet}(t))^T, (\bar{Q}_{2\bullet}(t))^T, \dots, (\bar{Q}_{p\bullet}(t))^T, d(t)). \tag{26}$$

With these definitions, one can rewrite (24a) and (24b) as

$$\dot{x} = Bz \tag{27a}$$

$$w = B^T Kx + Dz \tag{27b}$$

where $B \in \mathbb{R}^{n \times n(p+1)}$ and $D \in \mathbb{R}^{n(p+1) \times n(p+1)}$ with $D + D^T = 0$. As B is a matrix having more columns than rows, the assumption A.2 cannot be met. It is immediate that K is the unique solution to the the LMIs (6).

A key consequence of the assumptions A1 and A2 is that the transfer matrix $G(\sigma) = D + C(\sigma I - A)^{-1}B$ satisfies $\ker[G(\sigma) + G^T(\sigma)] = \{0\}$ due to Proposition 1 iv and Lemma 1 ix. As it is already positive real, this means that $G(\sigma)$ is positive definite for all sufficiently large real positive numbers σ . This property is the central idea behind the methods and arguments used in [10, 13, 21, 22]. To drop the assumption A2, one needs to take a completely new line of arguments.

4 Main results

The main goal of the paper is to establish existence and uniqueness conditions under the passivity assumption. This will be achieved in two steps. First, we find conditions under which ‘local’ solutions exist. In the next step, it will be shown that the ‘local’ solutions can be extended to the whole time axis. To do so, we need some nomenclature.

4.1 Bohl functions and distributions

A function $f : \mathbb{R}_+ \rightarrow \mathbb{R}^p$ is said to be a *Bohl function* if $f(t) = Z \exp(Xt)Y$ holds for all $t \geq 0$ and for some matrices X, Y , and Z with appropriate sizes. These functions appear as the solutions of linear and constant coefficient differential equations. If f is a Bohl function, its one-sided Laplace transform can be given by $\hat{f}(s) = Z(sI - X)^{-1}Y$. Note that \hat{f} is rational and strictly proper. Conversely, the inverse Laplace transform of a rational and strictly proper function is a Bohl function.

We say that a Bohl function f *initially lies in the cone* \mathcal{C} if there exists a positive number ϵ such that $f(t) \in \mathcal{C}$ for all $t \in [0, \epsilon)$. Let the cone \mathcal{C} be a polyhedral cone and the matrix M be such that $\mathcal{C} = \{\xi \in \mathbb{R}^p \mid M\xi \geq 0\}$. Since f is a real-analytic function, it initially lies in the cone \mathcal{C} if, and only if, the sequence $(Mf(0), Mf^{(1)}(0), Mf^{(2)}(0), \dots)$ is lexicographically nonnegative.

A distributional framework is needed to capture the sudden changes that are caused by the inconsistent initial states and/or input functions. Instead of working in the general framework of distributions, we focus on a subclass, namely to the distributions that are supported on a single point. A classical result [34, p. 100, Theorem XXXV] states that these distributions are linear combinations of the Dirac distribution and its derivatives. We say that f is an *impulsive distribution at* t if $f = \sum_{i=0}^{\ell} c_i \delta_t^{(i)}$ for some integer ℓ and real vectors $c_i \in \mathbb{R}^p$. Here, δ_t denotes the Dirac distribution that is supported at t , $\delta_t^{(i)}$ the i -th derivative of δ_t . By convention, $\delta_t^{(0)} = \delta_t$. Note that the Laplace transform of $f = \sum_{i=0}^{\ell} c_i \delta_0^{(i)}$ can be given as $\hat{f}(s) = c_{\ell} s^{\ell} + c_{\ell-1} s^{\ell-1} + \dots + c_1 s + c_0$.

Let the cone \mathcal{C} be a polyhedral cone and the matrix M be such that $\mathcal{C} = \{\xi \in \mathbb{R}^p \mid M\xi \geq 0\}$. We say that an impulsive distribution at $t = 0$, say $f = \sum_{i=0}^{\ell} c_i \delta_0^{(i)}$, initially lies in the cone \mathcal{C} if the finite vector sequence $(Mc_{\ell}, Mc_{\ell-1}, \dots, Mc_1, Mc_0)$ is lexicographically nonnegative.

A distribution f is said to be a *Bohl distribution* if it is the sum of an impulsive distribution at $t = 0$ and a Bohl function. In this case, we denote the impulsive part by f_{imp} and the rest, i.e. ‘regular’ part, by f_{reg} . We say that a Bohl distribution initially lies in the cone \mathcal{C} if one of the following conditions hold:

- $f_{\text{imp}} \neq 0$ and f_{imp} initially lies in the cone \mathcal{C} , or
- $f_{\text{imp}} = 0$ and f_{reg} initially lies in the cone \mathcal{C} .

We say that a Bohl distribution is of order 0 if it has no impulsive part and of order n if its impulsive part is given by $\sum_{i=0}^{n-1} c_i \delta_0^{(i)}$ with $c_{n-1} \neq 0$.

Another characterization of this property can be given in terms of the Laplace transform as follows.

Lemma 3 *Let \mathcal{C} be a polyhedral cone. A Bohl distribution f initially lies in the cone \mathcal{C} if, and only if, $\hat{f}(\sigma) \in \mathcal{C}$ for all sufficiently large $\sigma \in \mathbb{R}$.*

Proof If $f_{\text{imp}} = 0$ then the assertion follows from the initial value theorem of the Laplace transform [26]. The rest follows from the fact that if $f_{\text{imp}} \neq 0$ then its Laplace transform can be written as $\hat{f}(s) = c_{\ell} s^{\ell} + \hat{f}_{\text{rest}}(s)$ where $c_{\ell} \neq 0$ and $\hat{f}_{\text{rest}}(s)$ is a rational function with a degree less than ℓ . □

4.2 Initial solutions

We say that a triple of Bohl distributions (z, x, w) is an *initial solution* of the LCCS (20) for the initial state x_0 and the Bohl input u if there exists an index set $\alpha \subseteq \{1, 2, \dots, m\}$ such that the equations

$$\dot{x} = Ax + Bz + Eu + x_0 \delta_0 \tag{28a}$$

$$w = Cx + Dz + Fu \tag{28b}$$

$$w_{\alpha} = 0 \text{ and } z_{\alpha^c} = 0 \tag{28c}$$

hold in the sense of distributions and (z, w) initially lies in $\mathcal{C} \times \mathcal{C}^*$. Here α^c is the complement of the set α in $\{1, 2, \dots, m\}$. The solutions without having any impulsive part (i.e. $(z_{\text{imp}}, x_{\text{imp}}, w_{\text{imp}}) = 0$) are of particular interest. In this case, we say that the initial solution (z, x, w) is *regular*.

For the moment, we focus on the linear complementarity system, i.e. we take $\mathcal{C} = \mathbb{R}_+^m$. Note that $\mathcal{C}^* = (\mathbb{R}_+^m)^* = \mathbb{R}_+^m$. Consider the linear complementarity system

$$\dot{x}(t) = Ax(t) + Bz(t) + Eu(t) \tag{29a}$$

$$w(t) = Cx(t) + Dz(t) + Fu(t) \tag{29b}$$

$$0 \leq z(t) \perp w(t) \geq 0. \tag{29c}$$

We claim that if a triple (z, x, w) is an initial solution for the initial state x_0 and the input u then its Laplace transform satisfies

$$\hat{x}(s) = (sI - A)^{-1}x_0 + (sI - A)^{-1}E\hat{u}(s) + (sI - A)^{-1}B\hat{z}(s) \tag{30a}$$

$$\hat{w}(s) = C(sI - A)^{-1}x_0 + [F + C(sI - A)^{-1}E]\hat{u}(s) + [D + C(sI - A)^{-1}B]\hat{z}(s) \tag{30b}$$

$$\hat{z}^T(s)\hat{w}(s) = 0 \text{ for all complex numbers } s \tag{30c}$$

$$(\hat{z}(\sigma), \hat{w}(\sigma)) \geq 0 \text{ for all sufficiently large real numbers } \sigma. \tag{30d}$$

To see this, note that (30a–c) readily follow from (28) whereas (30d) follows from the fact that both z and w initially lie in the cone \mathbb{R}_+^m and Lemma 3.

Conversely, suppose that there exists a rational function $\hat{z}(s)$ such that the relations (30b–d) are satisfied. In this case, we claim that the inverse Laplace transform of the triple $(\hat{z}(s), \hat{x}(s), \hat{w}(s))$ is an initial solution for the initial state x_0 and the input u where $\hat{x}(s)$ is given by (30a). To see this, let the inverse transform be (z, x, w) . Obviously, (28a) and (28b) are satisfied by (z, x, w) . Lemma 3, together with (30d), implies that both z and w initially lie in \mathbb{R}_+^m . Then, it remains to prove that (28c) is satisfied for an index set α . Note that this would follow if we show

- i. either $\hat{z}_i(s) \equiv 0$
- ii. or $\hat{w}_i(s) \equiv 0$

for each index i . It follows from (30d) that for each i , $\hat{z}_i(\sigma)\hat{w}_i(\sigma) \geq 0$ for all sufficiently large σ . Then, it follows from (30c) that for each i , $\hat{z}_i(\sigma)\hat{w}_i(\sigma) = 0$ for all sufficiently large σ . Since both z and w are rational functions, one can conclude that at least one of the statements i or ii must hold.

This correspondence leads us to study complementarity problems of the form (30).

4.3 Rational complementarity problem

Given an m -tuple of rational functions $\hat{q}(s)$ and an $m \times m$ matrix of rational functions $M(s)$, the rational complementarity problem $\text{RCP}(\hat{q}(s), M(s))$ is to find an m -tuple of rational functions $\hat{z}(s)$ such that

$$\hat{w}(s) = \hat{q}(s) + M(s)\hat{z}(s) \tag{31a}$$

$$\hat{z}^T(s)\hat{w}(s) = 0 \text{ for all complex numbers } s \tag{31b}$$

$$(\hat{z}(\sigma), \hat{w}(\sigma)) \geq 0 \text{ for all sufficiently large real numbers } \sigma. \tag{31c}$$

If such a vector $\hat{z}(s)$ exists, we say that $\hat{z}(s)$ solves (is a solution of) $\text{RCP}(\hat{q}(s), M(s))$. The RCP has been introduced in [24] and further studied in [23]. The following theorem, which is the backbone of the well-posedness theory of linear complementarity systems, relates the solvability of an RCP to the solvability of a corresponding sequence of LCPs.

Theorem 3 [23, Theorem 4.1 and 4.9] *The following statements hold.*

1. *The $\text{RCP}(\hat{q}(s), M(s))$ has a solution if, and only if, the $\text{LCP}(\hat{q}(\sigma), M(\sigma))$ has a solution for all sufficiently large real numbers σ .*

2. The RCP($\hat{q}(s), M(s)$) has a unique solution if, and only if, the LCP($\hat{q}(\sigma), M(\sigma)$) has a unique solution for all sufficiently large real numbers σ .

4.4 Existence of initial solutions

Establishing necessary and sufficient conditions for the existence of initial solutions, the following theorem will be the base of the subsequent development.

Theorem 4 Consider the LCS (29) such that the system $\Sigma(A, B, C, D)$ is passive. Let $T_u(s) = F + C(sI - A)^{-1}E$ and $T_z(s) = D + C(sI - A)^{-1}B$. For given initial state x_0 and Bohl input u , define $\hat{q}(s) = C(sI - A)^{-1}x_0 + T_u(s)\hat{u}(s)$. Then, the following statements hold.

1. The following statements are equivalent.
 - (a) The LCS (29) has an initial solution for the initial state x_0 and the Bohl-type input u .
 - (b) The RCP($\hat{q}(s), T_z(s)$) has a solution.
 - (c) The RCP($\hat{q}(s), T_z(s)$) has a proper solution.
 - (d) The function Fu initially lies in the cone $\mathcal{Q}^*_D + \text{im } C$.
2. The following statements are equivalent.
 - (a) The LCS (29) has a regular initial solution for the initial state x_0 and the Bohl-type input u .
 - (b) The RCP($\hat{q}(s), T_z(s)$) has a strictly proper solution.
 - (c) The function Fu initially lies in the cone $\mathcal{Q}^*_D + \text{im } C$ and $Cx_0 + Fu(0) \in \mathcal{Q}^*_D$.
3. If the LCS (29) admits two initial solutions (z^1, x^1, w^1) and (z^2, x^2, w^2) for the initial state x_0 and the Bohl-type input u then
 - (a) $z^1 - z^2 \in \ker \begin{bmatrix} KB \\ D + D^T \end{bmatrix}$.
 - (b) $Kx^1 = Kx^2$.
 - (c) $w^1 - w^2 \in D \ker \begin{bmatrix} KB \\ D + D^T \end{bmatrix}$.

To prove this theorem, we need three auxiliary lemmas. The first one is self-evident.

Lemma 4 If a real vector sequence (a_1, a_2, a_3) is lexicographically nonnegative then $(\rho a_1 + a_2, a_3)$ is also lexicographically nonnegative for all sufficiently large positive real numbers ρ .

The second lemma gives conditions under which existence of a solution leads to existence of a lesser degree solution.

Lemma 5 Let N be a positive integer and let $\hat{z}(s) = z_N s^N + z_{N-1} s^{N-1} + \hat{z}_{\text{rest}}(s)$ where \hat{z}_{rest} is a rational function with a degree less than $N - 1$. Suppose that $\hat{z}(s)$ is a solution of the RCP($\hat{q}(s), T_z(s)$). Then, $z_N \in \ker \begin{bmatrix} KB \\ D + D^T \end{bmatrix}$ and $\hat{z}_{\text{new}}(s) := (\mu z_N + z_{N-1})s^{N-1} + \hat{z}_{\text{rest}}(s)$ is also a solution of the RCP($\hat{q}(s), T_z(s)$) for all sufficiently large nonnegative μ .

Proof Note that

$$\begin{aligned} \hat{w}(s) &= \hat{q}(s) + T_z(s)\hat{z}(s) & (32) \\ &= \hat{q}(s) + [D + C(sI - A)^{-1}B][z_N s^N + z_{N-1}s^{N-1} + \hat{z}_{\text{rest}}(s)]. & (33) \end{aligned}$$

Since $\hat{q}(s)$ is strictly proper and N is a positive integer, it follows from $\hat{z}^T(s)\hat{w}(s) \equiv 0$ that

$$\begin{aligned} z_N^T D z_N &= 0 & (34) \\ z_N^T D z_{N-1} + z_N^T C B z_N + z_{N-1}^T D z_N &= 0. & (35) \end{aligned}$$

Since D is nonnegative definite due to passivity, (34) implies $z_N \in \ker(D + D^T)$. Along with (35), this means that $z_N^T C B z_N = 0$. Due to Lemma 1 iv, one gets $z_N \in \ker \begin{bmatrix} K B \\ D + D^T \end{bmatrix}$. To prove the rest, it is necessary to show that

$$\begin{aligned} \hat{w}_{\text{new}}(s) &:= \hat{q}(s) + T_z(s)\hat{z}_{\text{new}}(s) & (36a) \\ \hat{z}_{\text{new}}^T(s)\hat{w}_{\text{new}}(s) &= 0 \text{ for all complex numbers } s & (36b) \\ (\hat{z}_{\text{new}}(\sigma), \hat{w}_{\text{new}}(\sigma)) &\geq 0 \text{ for all sufficiently large real numbers } \sigma. & (36c) \end{aligned}$$

Note that

$$\begin{aligned} \hat{z}(s) &= z_N s^N + z_{N-1}s^{N-1} + \hat{z}_{\text{rest}}(s) & (37a) \\ \hat{z}_{\text{new}}(s) &= (\mu z_N + z_{N-1})s^{N-1} + \hat{z}_{\text{rest}}(s). & (37b) \end{aligned}$$

Hence, one can conclude from Lemma 4 that $\hat{z}_{\text{new}}(\sigma) \geq 0$ for all sufficiently large σ and sufficiently large μ . Since $z_N \in \ker \begin{bmatrix} K B \\ D + D^T \end{bmatrix}$, it follows from Lemma 1.viii that $T_z(s)z_N = D z_N$. This results in

$$\begin{aligned} \hat{w}(s) &= \hat{q}(s) + T_z(s)\hat{z}(s) & (38a) \\ &= D z_N s^N + T_z(s)z_{N-1}s^{N-1} + \hat{q}(s) + T_z(s)\hat{z}_{\text{rest}}(s) & (38b) \\ \hat{w}_{\text{new}}(s) &= \hat{q}(s) + T_z(s)\hat{z}_{\text{new}}(s) & (38c) \\ &= \mu D z_N s^{N-1} + T_z(s)z_{N-1}s^{N-1} + \hat{q}(s) + T_z(s)\hat{z}_{\text{rest}}(s). & (38d) \end{aligned}$$

As $\hat{z}(s)$ is a solution of the RCP($\hat{q}(s), T_z(s)$) and $\hat{q}(s) + T_z(s)\hat{z}_{\text{rest}}(s)$ is a rational function with a degree less than $N - 1$, we arrive at the conclusion that $\hat{w}_{\text{new}}(\sigma) \geq 0$ for all sufficiently large positive real numbers σ by applying Lemmas 3 and 4 to (38b). So far, we showed that the relation (36c) holds. To see that the relation (36b) holds, note that for each index i either $\hat{z}_i(s) \equiv 0$ or $\hat{w}_i(s) \equiv 0$. This readily results in $(\hat{z}_{\text{new}}(s))_i \equiv 0$ via (37) when $\hat{z}_i(s) \equiv 0$. Likewise, $\hat{w}_i(s) \equiv 0$ implies $(\hat{w}_{\text{new}}(s))_i \equiv 0$. To see this, note that $\hat{w}_i(s) \equiv 0$ implies $(\hat{q}(s) + T_z(s)\hat{z}_{\text{rest}}(s) + T_z(s)z_{N-1}s^{N-1})_i \equiv 0$ and $(D z_N)_i = 0$ as the former is degree of at most $N - 1$. Therefore, one gets $\hat{z}_{\text{new}}^T(s)\hat{w}_{\text{new}}(s) = 0$. Thus, $\hat{z}_{\text{new}}(s)$ is a solution to RCP($\hat{q}(s), T_z(s)$). \square

The third lemma presents conditions under which existence of a strictly proper solution can be concluded from that of a proper solution.

Lemma 6 *Let $\hat{z}(s) = z_0 + \hat{z}_{\text{rest}}(s)$ where \hat{z}_{rest} is a strictly proper rational function. Suppose that $\hat{z}(s)$ is a solution of the RCP($\hat{q}(s), T_z(s)$) and $z_0 \in \ker \begin{bmatrix} KB \\ D + D^T \end{bmatrix}$. Then, $\hat{z}_{\text{new}}(s) := \mu z_0 s^{-1} + \hat{z}_{\text{rest}}(s)$ is also a solution of the RCP($\hat{q}(s), T_z(s)$) for all sufficiently large μ .*

Proof We need to show that

$$\hat{w}_{\text{new}}(s) := \hat{q}(s) + T_z(s)\hat{z}_{\text{new}}(s) \tag{39a}$$

$$\hat{z}_{\text{new}}^T(s)\hat{w}_{\text{new}}(s) = 0 \text{ for all complex numbers } s \tag{39b}$$

$$(\hat{z}_{\text{new}}(\sigma), \hat{w}_{\text{new}}(\sigma)) \geq 0 \text{ for all sufficiently large real numbers } \sigma. \tag{39c}$$

Note that

$$\hat{z}(s) = z_0 + \hat{z}_{\text{rest}}(s) \tag{40a}$$

$$\hat{z}_{\text{new}}(s) = \mu z_0 s^{-1} + \hat{z}_{\text{rest}}(s). \tag{40b}$$

Hence, one can conclude from Lemma 4 that $\hat{z}_{\text{new}}(\sigma) \geq 0$ for all sufficiently large σ and sufficiently large μ . Since $z_0 \in \ker \begin{bmatrix} KB \\ D + D^T \end{bmatrix}$, it follows from Lemma 1.viii that $T_z(s)z_N = Dz_N$. This results in

$$\hat{w}(s) = \hat{q}(s) + T_z(s)\hat{z}(s) \tag{41a}$$

$$= Dz_0 + \hat{q}(s) + T_z(s)\hat{z}_{\text{rest}}(s) \tag{41b}$$

$$\hat{w}_{\text{new}}(s) = \hat{q}(s) + T_z(s)\hat{z}_{\text{new}}(s) \tag{41c}$$

$$= \mu Dz_0 s^{-1} + \hat{q}(s) + T_z(s)\hat{z}_{\text{rest}}(s). \tag{41d}$$

As $\hat{z}(s)$ is a solution of the RCP($\hat{q}(s), T_z(s)$) and $\hat{q}(s) + T_z(s)\hat{z}_{\text{rest}}(s)$ is strictly proper, we arrive at the conclusion that $\hat{w}_{\text{new}}(\sigma) \geq 0$ for all sufficiently large positive real numbers σ by applying Lemma 4 to (41b). So far, we showed that the relation (39c) holds. To see the relation (39b) holds, note that for each index i either $\hat{z}_i(s) \equiv 0$ or $\hat{w}_i(s) \equiv 0$. This readily results in $(\hat{z}_{\text{new}}(s))_i \equiv 0$ via (40) when $\hat{z}_i(s) \equiv 0$. Likewise, $\hat{w}_i(s) \equiv 0$ implies $(\hat{w}_{\text{new}}(s))_i \equiv 0$. To see this, note that $\hat{w}_i(s) \equiv 0$ implies $(\hat{q}(s) + T_z(s)\hat{z}_{\text{rest}}(s))_i \equiv 0$ and $(Dz_0)_i = 0$ as the former is strictly proper. Therefore, one gets $\hat{z}_{\text{new}}^T(s)\hat{w}_{\text{new}}(s) = 0$. Thus, $\hat{z}_{\text{new}}(s)$ is a solution to RCP($\hat{q}(s), T_z(s)$). \square

Proof of Theorem 4 1a \Leftrightarrow 1b: This is evident from the discussion in Sect. 4.2.

1b \Leftrightarrow 1c: Obviously, 1c implies 1b. For the converse, let $N \geq 1$ and $\hat{z}(s) = z_N s^N + z_{N-1} s^{N-1} + \hat{z}_{\text{rest}}(s)$, where \hat{z}_{rest} is a rational function with a degree less than $N - 1$, be a solution of RCP($\hat{q}(s), T_z(s)$). By repeatedly applying Lemma 5, one obtains a proper solution.

1c \Leftrightarrow 1d: It follows from Theorems 3 and 2 that the RCP($\hat{q}(s), T_z(s)$) has a solution if and only if $\hat{q}(\sigma) \in \mathcal{Q}^*_{T_z(\sigma)}$ for all sufficiently large real numbers σ . We know

from Lemma 2 that $\mathcal{Q}^*_{T_z(\sigma)} = \mathcal{Q}^*_D + \text{im } C$. Note that $p + r \in \mathcal{Q}^*_D + \text{im } C$ with $p \in \text{im } C$ if and only if $r \in \mathcal{Q}^*_D + \text{im } C$. This means that $\hat{q}(\sigma) = C(\sigma I - A)^{-1}x_0 + [F + C(\sigma I - A)^{-1}E]\hat{u}(\sigma) \in \mathcal{Q}^*_D$ for all sufficiently large real numbers σ if and only if the same holds for $F\hat{u}(\sigma) \in \mathcal{Q}^*_D + \text{im } C$. The latter holds if and only if Fu initially lies in the cone $\mathcal{Q}^*_D + \text{im } C$ due to Lemma 3.

2a \Leftrightarrow 2b: This is evident from the discussion in Sect. 4.2.

2b \Rightarrow 2c: Since $\text{RCP}(\hat{q}(s), T_z(s))$ is solvable, it follows from the statement 1 that Fu initially lies in the cone $\mathcal{Q}^*_D + \text{im } C$. For the rest, let $\hat{z}(s) = z_{-1}s^{-1} + \hat{z}_{\text{rest}}(s)$, where \hat{z}_{rest} is a rational function with a degree less than -1 , be a strictly proper solution of $\text{RCP}(\hat{q}(s), T_z(s))$. The relations (31) result in

$$z_{-1} \geq 0 \tag{42}$$

$$Cx_0 + Fu(0) + Dz_{-1} \geq 0 \tag{43}$$

$$z_{-1} \perp Cx_0 + Fu(0) + Dz_{-1}. \tag{44}$$

In other words, z_{-1} solves the $\text{LCP}(Cx_0 + Fu(0), D)$. Due to Theorem 2, $Cx_0 + Fu(0) \in \mathcal{Q}^*_D$.

2c \Rightarrow 2b: Suppose that Fu initially lies in the cone $\mathcal{Q}^*_D + \text{im } C$ and $Cx_0 + Fu(0) \in \mathcal{Q}^*_D$. The former relation, along with the statement 1, means that the $\text{RCP}(\hat{q}(s), T_z(s))$ has a proper solution, i.e. there exists a proper rational function $\hat{z}(s)$ such that

$$\hat{z}(\sigma) \geq 0 \tag{45a}$$

$$\hat{w}(\sigma) = \hat{q}(\sigma) + T_z(\sigma)\hat{z}(\sigma) \geq 0 \tag{45b}$$

for all sufficiently large real numbers σ and

$$\hat{z}^T(s)\hat{w}(s) = 0 \tag{45c}$$

for all complex numbers s . Since $Cx_0 + Fu(0) \in \mathcal{Q}^*_D$, there must exist a vector \bar{z} such that

$$\bar{z} \geq 0 \tag{46a}$$

$$\bar{w} = Cx_0 + Fu(0) + D\bar{z} \geq 0 \tag{46b}$$

$$\bar{z}^T(Cx_0 + Fu(0) + D\bar{z}) = 0. \tag{46c}$$

Straightforward algebraic manipulations yield

$$\bar{z}\sigma^{-1} \geq 0 \tag{47a}$$

$$\bar{w}\sigma^{-1} = (Cx_0 + Fu(0))\sigma^{-1} - C(\sigma I - A)^{-1}B\bar{z}\sigma^{-1} + T_z(\sigma)\bar{z}\sigma^{-1} \geq 0 \tag{47b}$$

$$(\bar{z}\sigma^{-1})^T[(Cx_0 + Fu(0))\sigma^{-1} - C(\sigma I - A)^{-1}B\bar{z}\sigma^{-1} + T_z(\sigma)\bar{z}\sigma^{-1}] = 0 \tag{47c}$$

for all positive numbers σ . By using (45) and (47), one gets

$$(\hat{z}(\sigma) - \bar{z}\sigma^{-1})^T(\hat{w}(\sigma) - \bar{w}\sigma^{-1}) \leq 0. \tag{48}$$

This results in

$$\begin{aligned}
 & (\hat{z}(\sigma) - \bar{z}\sigma^{-1})^T T_z(\sigma) (\hat{z}(\sigma) - \bar{z}\sigma^{-1}) \\
 & \leq -(\hat{z}(\sigma) - \bar{z}\sigma^{-1})^T [\hat{q}(\sigma) - (Cx_0 + Fu(0))\sigma^{-1} + C(\sigma I - A)^{-1}B\bar{z}\sigma^{-1}]
 \end{aligned}$$

for all sufficiently large real numbers σ . Note that the right hand side of this inequality is of order σ^{-2} . Let $\hat{z}(s) = z_0 + \hat{z}_{\text{rest}}(s)$ where $\hat{z}_{\text{rest}}(s)$ is a strictly proper rational function. Then, the last inequality can be rewritten as

$$\begin{aligned}
 & z_0^T Dz_0 + (z_0^T Dz_{-1} + z_{-1}^T Dz_0 - \bar{z}^T Dz_0 - z_0^T D\bar{z} + z_0^T CBz_0)\sigma^{-1} + O(\sigma^{-2}) \\
 & \leq O(\sigma^{-2}).
 \end{aligned} \tag{49}$$

By taking the limit as σ tends to infinity, one gets

$$z_0^T Dz_0 = 0 \tag{50}$$

since D is nonnegative definite due to the hypotheses. By multiplying by σ both sides and taking the limit as σ tends to infinity, one gets

$$z_0^T Dz_{-1} + z_{-1}^T Dz_0 - \bar{z}^T Dz_0 - z_0^T D\bar{z} + z_0^T CBz_0 = 0. \tag{51}$$

Together with (50), this results in $z_0^T CBz_0 = 0$. Hence, $z_0 \in \ker \begin{bmatrix} KB \\ D + D^T \end{bmatrix}$ due to Lemma 1 statement iv. Now, one can invoke Lemma 6 and get a strictly proper solution.

3a: It follows from complementarity that $(\hat{z}^1(\sigma) - \hat{z}^2(\sigma))^T (\hat{w}^1(\sigma) - \hat{w}^2(\sigma)) \leq 0$ for all sufficiently large real numbers σ . Note that $\hat{w}^1(\sigma) - \hat{w}^2(\sigma) = T_z(\sigma)((\hat{z}^1(\sigma) - \hat{z}^2(\sigma)))$. Hence, we get

$$(\hat{z}^1(\sigma) - \hat{z}^2(\sigma))^T T_z(\sigma) (\hat{z}^1(\sigma) - \hat{z}^2(\sigma)) \leq 0 \tag{52}$$

for all sufficiently large real numbers σ . Since $T_z(s)$ is positive real due to Proposition 1, one further gets

$$(\hat{z}^1(\sigma) - \hat{z}^2(\sigma))^T T_z(\sigma) (\hat{z}^1(\sigma) - \hat{z}^2(\sigma)) = 0 \tag{53}$$

and hence $(T_z(\sigma) + T_z^T(\sigma))(\hat{z}^1(\sigma) - \hat{z}^2(\sigma)) = 0$ for all sufficiently large real numbers σ . It follows from Lemma 1.ix that

$$\hat{z}^1(\sigma) - \hat{z}^2(\sigma) \in \ker \begin{bmatrix} KB \\ D + D^T \end{bmatrix} \tag{54}$$

for all sufficiently large real numbers σ that are not eigenvalues of A . Since the left hand side is a rational function of σ , one gets

$$\hat{z}^1(s) - \hat{z}^2(s) \in \ker \begin{bmatrix} KB \\ D + D^T \end{bmatrix}. \tag{55}$$

3b: Note that $\hat{x}^1(s) - \hat{x}^2(s) \equiv B(\hat{z}^1(s) - \hat{z}^2(s))$. By left multiplying and using the statement 3a, one gets $K(\hat{x}^1 - \hat{x}^2) \equiv 0$.

3c: Note that $\hat{w}^1(s) - \hat{w}^2(s) = C(\hat{x}^1(s) - \hat{x}^2(s)) + D(\hat{z}^1(s) - \hat{z}^2(s))$. It follows from the statement 3b and Lemma 1 vii that $C(\hat{x}^1(s) - \hat{x}^2(s)) \equiv 0$. The rest follows from statement 3a. \square

Remark 1 Note that

$$\mathcal{Q}_{G(\sigma)} = \mathcal{Q}_D \cap \ker C^T \subseteq \ker \begin{bmatrix} C^T \\ D + D^T \end{bmatrix} = \ker \begin{bmatrix} KB \\ D + D^T \end{bmatrix}.$$

As such, the assumptions A1 and A2 guarantee that

$$\ker \begin{bmatrix} KB \\ D + D^T \end{bmatrix} = \{0\}.$$

Consequently, $\mathcal{Q}_{G(\sigma)} = \{0\}$ and $\mathcal{Q}_{G(\sigma)}^* = \mathbb{R}^m$. Hence, all results on the initial solutions of linear passive complementarity systems [8, 10, 13, 19, 21, 22] can be recovered from Theorem 4 as special cases.

Next, we show that the x -trajectories of regular initial solutions are Lipschitz continuous.

Theorem 5 Consider the LCS (29) such that the system $\Sigma(A, B, C, D)$ is passive. Suppose that the LMIs (6) have a positive definite solution. Let (z, x, w) be a regular initial solution of the LCS (29) for some initial state and the Bohl input u . Let $\alpha \subseteq \{1, 2, \dots, m\}$ and $\varepsilon > 0$ be such that

$$w_\alpha(t) = 0 \text{ and } z_{\alpha^c}(t) = 0 \text{ for all } t \in \mathbb{R}_+ \tag{56}$$

$$z_\alpha(t) \geq 0 \text{ and } w_{\alpha^c}(t) \geq 0 \text{ for all } t \in [0, \varepsilon]. \tag{57}$$

Then, there exist some matrices K_x and K_u that depend only on the input u , the matrices (A, B, C, D, E, F) and α such that

$$\dot{x}(t) = (A + B_{\bullet\alpha}K_x)x(t) + (ER + B_{\bullet\alpha}K_u)e^{Pt}Q \tag{58}$$

where $u(t) = Re^{Pt}Q$.

Proof By the hypotheses, one has

$$\dot{x}(t) = Ax(t) + B_{\bullet\alpha}z_\alpha(t) + Eu(t) \tag{59a}$$

$$0 = C_{\alpha\bullet}x(t) + D_{\alpha\alpha}z_\alpha(t) + F_{\alpha\bullet}u(t) \tag{59b}$$

for all $t \in \mathbb{R}_+$. Since u is a Bohl function, there exist matrices $P \in \mathbb{R}^{\ell \times \ell}$, $Q \in \mathbb{R}^{\ell \times 1}$, and $R \in \mathbb{R}^{k \times \ell}$ such that $u(t) = Re^{Pt}Q$ for all t . By defining $\bar{u}(t) = e^{Pt}Q$, $\xi = \text{col}(x, \bar{u})$, and $\zeta = z_\alpha$, one can rewrite (59) as

$$\dot{\xi}(t) = \mathcal{A}\xi(t) + \mathcal{B}\zeta(t) \tag{60a}$$

$$0 = \mathcal{C}\xi(t) + \mathcal{D}\zeta(t) \tag{60b}$$

for all $t \in \mathbb{R}_+$ where

$$\mathcal{A} = \begin{bmatrix} A & ER \\ 0 & P \end{bmatrix}, \quad \mathcal{B} = \begin{bmatrix} B_{\bullet\alpha} \\ 0 \end{bmatrix} \tag{61a}$$

$$\mathcal{C} = [C_{\alpha\bullet} \quad F_{\alpha\bullet}R], \quad \mathcal{D} = D_{\alpha\alpha}. \tag{61b}$$

Let \mathcal{V}^* be the largest output-nulling controlled-invariant subspace for the linear system given by $(\mathcal{A}, \mathcal{B}, \mathcal{C}, \mathcal{D})$ as defined in Appendix 2.

It follows from (60) and Theorem 12 that $\xi(0) = \text{col}(x(0), \bar{u}(0)) \in \mathcal{V}^*$ and $\zeta = L\xi + v$ where $L \in \mathcal{L}$ and v is an integrable function with $v(t) \in \ker \bar{D} \cap \bar{B}^{-1}\mathcal{V}^*$ for all $t \in \mathbb{R}_+$. Hence, $z_\alpha = \zeta = K_x x + K_u \bar{u} + v$ for some matrices K_x and K_u . Then, (59) and (60) yield

$$\dot{x}(t) = (A + B_{\bullet\alpha}K_x)x(t) + (ER + B_{\bullet\alpha}K_u)\bar{u}(t) + B_{\bullet\alpha}v(t) \tag{62a}$$

$$0 = (C_{\alpha\bullet} + D_{\alpha\alpha}K_x)x(t) + (F_{\alpha\bullet}R + D_{\alpha\alpha}K_u)\bar{u}(t). \tag{62b}$$

Now, consider the differential equation

$$\dot{\tilde{\xi}} = \mathcal{A}\tilde{\xi}(t) + \mathcal{B}\tilde{\zeta}(t) \tag{63a}$$

where $\tilde{\xi}(0) = \xi(0) = \text{col}(x(0), \bar{u}(0)) \in \mathcal{V}^*$. It follows from Theorem 12 that

$$0 = \mathcal{C}\tilde{\xi}(t) + \mathcal{D}\tilde{\zeta}(t) \tag{63b}$$

if we choose $\tilde{\zeta} = L\tilde{\xi}$. From (61a), (63a), and $\tilde{\xi}(0) = \xi(0) = \text{col}(x(0), \bar{u}(0))$, we can conclude that $\tilde{\xi} = \text{col}(\tilde{x}, \bar{u})$. Then, it follows from (63) that

$$\dot{\tilde{x}}(t) = (A + B_{\bullet\alpha}K_x)\tilde{x}(t) + (ER + B_{\bullet\alpha}K_u)\bar{u}(t) \tag{64a}$$

$$0 = (C_{\alpha\bullet} + D_{\alpha\alpha}K_x)\tilde{x}(t) + (F_{\alpha\bullet}R + D_{\alpha\alpha}K_u)\bar{u}(t) \tag{64b}$$

with the initial condition $\tilde{x}(0) = x(0)$. Define $\hat{x} = x - \tilde{x}$ and $\hat{z} = K_x \hat{x}$. By subtracting (64) from (62) and using the property $v \in \ker D_{\alpha\alpha}$ for all $t \in \mathbb{R}_+$, we obtain

$$\dot{\hat{x}} = A\hat{x} + B_{\bullet\alpha}(v + \hat{z}) \tag{65a}$$

$$0 = C_{\alpha\bullet}\hat{x} + D_{\alpha\alpha}(v + \hat{z}). \tag{65b}$$

It follows from Proposition 1 that the linear system $\Sigma(A, B_{\bullet\alpha}, C_{\alpha\bullet}, D_{\alpha\alpha})$ is passive with any storage function of the system $\Sigma(A, B, C, D)$. Therefore, we can apply the dissipation inequality (5) and obtain

$$\hat{x}^T(t)K\hat{x}(t) \leq \hat{x}^T(0)K\hat{x}(0) \tag{66}$$

for all $t \in \mathbb{R}_+$ where K is any positive definite solution of the LMIs (6). Since $\hat{x}(0) = 0$ by definition, it follows from positive definiteness of K that $\hat{x}(t) = 0$ for all $t \in \mathbb{R}_+$. Hence, (65a) implies that

$$0 = B_{\bullet\alpha}(\bar{v}(t) + \hat{z}(t)) = B_{\bullet\alpha}(v(t) + K_x\hat{x}(t)) = B_{\bullet\alpha}v(t) \tag{67}$$

for almost all $t \in \mathbb{R}_+$. Further, we get $B_{\bullet\alpha}z_\alpha = B_{\bullet\alpha}(K_x x + K_u \bar{u} + v) = B_{\bullet\alpha}(K_x x + K_u \bar{u})$. Then, (58) follows from (62). \square

4.5 Global solutions

In the previous section, we established existence and uniqueness results on the initial solution concept. By definition, this is a ‘local’ notion of solution that describes the behavior of the system on a short interval of time. Next, we show that one can concatenate these initial solutions in order to construct a global solution.

Let T be a positive number. We say that a triple (z, x, w) , where x is absolutely continuous and (z, w) is locally integrable,

- is a *solution* of (20) on $[0, T)$ for the initial state x_0 and the input u if $x(0) = x_0$ and (20) is satisfied almost everywhere on $[0, T)$.
- is a *forward solution* of (20) on $[0, T)$ for the initial state x_0 and the input u if (z, x, w) is a solution on $[0, T)$ and for each $\bar{t} \in [0, T)$ there exist $\epsilon_{\bar{t}} > 0$ and an index set $\alpha(\bar{t}) \subseteq \{1, 2, \dots, m\}$ such that

$$\dot{x}(t) = Ax(t) + Bz(t) + Eu(t) \tag{68a}$$

$$w(t) = Cx(t) + Dz(t) + Fu(t) \tag{68b}$$

$$z_{\alpha(\bar{t})}(t) \geq 0 \quad w_{\alpha(\bar{t})}(t) = 0 \tag{68c}$$

$$z_{\alpha^c(\bar{t})}(t) = 0 \quad w_{\alpha^c(\bar{t})}(t) \geq 0 \tag{68d}$$

holds for all $t \in (\bar{t}, \bar{t} + \epsilon)$. Here α^c denotes the complement of the set α in $\{1, 2, \dots, m\}$.

Remark 2 Suppose that D is a nonnegative matrix. For existence of solutions on an interval $[0, T)$ for an input u , the relation

$$Fu(t) \in \mathcal{Q}^*_D + \text{im } C \text{ for almost all } t \in [0, T) \tag{69}$$

is a necessary condition. To see this, let the triple (z, x, w) be a solution on $[0, T)$ for some initial state and the input u , then the relation

$$0 \leq z(t) \perp Cx(t) + Dz(t) + Fu(t) \geq 0 \tag{70}$$

holds for almost all $t \in [0, T)$. This would mean that the LCP($Cx(t) + Fu(t), D$) is solvable for almost all $t \in [0, T)$. In view of Theorem 2, (70) holds if and only if $Cx(t) + Fu(t) \in \mathcal{Q}^*_D$ holds for almost all $t \in [0, T)$. Clearly, this implies (69).

Remark 3 Suppose that the linear system $\Sigma(A, B, C, D)$ is passive and the LMIs (6) have a positive definite solution K . Let the triples (z^i, x^i, w^i) with $i = 1, 2$ be two solutions of the system (20) on $[0, T)$ for the same initial state and the input. Note that $(z^1 - z^2, x^1 - x^2, w^1 - w^2)$ is a trajectory of the linear system $\Sigma(A, B, C, D)$ for the zero initial state and $(z^1(t) - z^2(t))^T(w^1(t) - w^2(t)) \leq 0$ for almost all $t \in [0, T)$. Then, the dissipation inequality (5) results in

$$(x^1(t) - x^2(t))^T K(x^1(t) - x^2(t)) \leq 0 \tag{71}$$

for all t . This means that $x^1 = x^2$ since K is positive definite. Hence, the dissipation inequality (5) implies that $x^1(t) = x^2(t)$ for all $t \in [0, T)$, i.e. passivity with a positive definite storage function immediately implies uniqueness of x -trajectories.

Remark 4 Note that if (z, x, w) is a regular initial solution for some initial state and input then it is a forward solution for the same initial state and input on $[0, \bar{\epsilon})$ where $\bar{\epsilon} := \sup \{ \epsilon \mid (z(t), w(t)) \geq 0 \text{ for all } t \in [0, \epsilon) \}$. For ease of reference, we define $\theta(z, x, w) = \bar{\epsilon}$ for any regular initial solution (z, x, w) .

Remark 5 Consider the LCS (29) such that the system $\Sigma(A, B, C, D)$ is passive. Let u be an input satisfying (69) and \bar{x}^0 be an initial solution satisfying $C\bar{x}^0 + Fu(0) \in \mathcal{Q}^*_D$. Existence of a regular initial state, say (z^0, x^0, w^0) , for the initial state x^0 and the input u follows from Theorem 4. Let $\epsilon_0 := \theta(z^0, x^0, w^0)$. Then, (z^0, x^0, w^0) is a forward solution for the same initial state and input on $[0, \epsilon_0)$ due to Remark 4. Further,

$$Cx^0(t) + Fu(t) \in \mathcal{Q}^*_D \tag{72}$$

for all $t \in [0, \epsilon_0)$. Since x^0 is a Bohl function, the limit $\lim_{t \uparrow \epsilon_0} x^0(t)$ exists and equals to $\bar{x}^1 := x^0(\epsilon_0)$. As u is a Bohl function and \mathcal{Q}^*_D is closed, (72) results in $C\bar{x}^1 + Fu(\epsilon_0) \in \mathcal{Q}^*_D$. Then, it follows from Theorem 4.2 that there must exist an initial solution, say (z^1, x^1, w^1) , for the initial state \bar{x}^1 and the input $t \mapsto u(t + \epsilon_0)$. Define $\epsilon_1 := \theta(z^1, x^1, w^1)$. It is easy to see that the concatenation

$$(z, x, w)(t) = \begin{cases} (z^0, x^0, w^0)(t) & \text{if } t < \epsilon_0 \\ (z^1, x^1, w^1)(t - \epsilon_0) & \text{if } \epsilon_0 \leq t \leq \epsilon_0 + \epsilon_1 \end{cases} \tag{73}$$

is a forward solution on $[0, \epsilon_0 + \epsilon_1)$. One can extend this solution by repeating the same argument. This process produces the following three cases:

1. For some integer i , ϵ_i is not finite: Clearly, the above process yields a solution on every interval $[0, T)$.
2. For all integers i , ϵ_i is finite and $\sum_{i=0}^{\infty} \epsilon_i$ diverges: In this case, there exists an integer j such that $\sum_{i=0}^j \epsilon_i \geq T$ for any $T > 0$. As such, repetition of the above process yields a solution on every interval $[0, T)$.

3. For all integers i , ϵ_i is finite and $\sum_{i=0}^{\infty} \epsilon_i = T^*$: In this case, one can obtain a solution on the interval $[0, T^*)$. To extend this a solution beyond T^* , it is enough to show that the limit of the state trajectory at T^* exists. In the earlier work [10,13,21,22], this was achieved by the uniqueness of the initial solutions that is guaranteed by the assumption A.2. In absence of this assumption, this limit does not *a priori* exist. Below we show that the mentioned limit exists in case the LMIs (6) admit a positive definite solution.

Theorem 6 Consider the LCS (29) such that the system $\Sigma(A, B, C, D)$ is passive. Suppose that the LMIs (6) have a positive definite solution. Let T be a positive number and let the Bohl-type input u satisfy (69). Suppose that there exists a forward solution on $[0, T)$ for an initial state and the input u . Then, for some positive number ϵ there exists a forward solution on $[0, T + \epsilon)$ for the same initial state and input.

Proof Let (z, x, w) be a forward solution on $[0, T)$. Due to the complementarity relations (29b–c) and Theorem 2, one gets

$$Cx(t) + Fu(t) \in \mathcal{Q}_D^* \tag{74}$$

for all $t \in [0, T)$. Due to the definition of regular initial solutions and Theorem 5, for each $\bar{t} \in [0, T)$ there must exist $\epsilon_{\bar{t}} > 0$, $\alpha(\bar{t}) \subseteq \{1, 2, \dots, m\}$, $K_x^{\alpha(\bar{t})}$, and $K_u^{\alpha(\bar{t})}$ such that

$$\dot{x}(t) = [A + B_{\bullet\alpha(\bar{t})} K_x^{\alpha(\bar{t})}]x(t) + [ER + B_{\bullet\alpha(\bar{t})} K_u^{\alpha(\bar{t})}]e^{Pt} Q \tag{75}$$

for all $t \in (\bar{t}, \bar{t} + \epsilon_{\bar{t}})$ where $u(t) = Re^{Pt} Q$. Therefore, we can conclude that x is Lipschitz continuous and hence uniformly continuous on $[0, T)$. As such, $x^* := \lim_{t \rightarrow T} x(t)$ exists (see e.g. [32, Ex. 4.13]. In view of (74) and (69), it follows from Theorem 4 that there exists a regular initial solution for the initial state x^* and the input $t \mapsto u(t - T)$. By concatenating (z, x, w) and this regular initial solution, we obtain a forward solution on $[0, T + \epsilon)$ for some $\epsilon > 0$. □

Remark 6 Above theorem deals with the case that the underlying system admits a positive definite storage function. It is possible to formulate a similar result for the nonnegative definite case. In this case, however, the concatenation process must be modified as concatenations of arbitrary initial solutions may not be extended arbitrarily in general. To prevent this, one should choose an initial solution among all possible ones in such a way that the existence of the state trajectory lying in $\ker K$ is guaranteed.

Theorem 7 Consider the LCS (29) such that the system $\Sigma(A, B, C, D)$ is passive. Suppose that the LMIs (6) have a positive definite solution. Then, the following statements are equivalent for a given positive real number T , an initial state x_0 , and an input u .

1. There exists a solution for the initial state x_0 and the input u on $[0, T)$.
2. There exists a forward solution for the initial state x_0 and the input u on $[0, T)$.

3. The relations

$$Fu(t) \in \mathcal{Q}_D^* + \text{im } C \text{ for all } t \in [0, T] \tag{76a}$$

$$Cx_0 + Fu(0) \in \mathcal{Q}_D^* \tag{76b}$$

hold.

Moreover, if $(z^i, x^i, w^i) \ i = 1, 2$ are solutions with the initial state x_0 , and the input u , then the relations

- i. $x^1 - x^2 = 0$,
- ii. $z^1 - z^2 \in \ker \begin{bmatrix} B \\ D + D^T \end{bmatrix}$,
- iii. $w^1 - w^2 \in D \ker \begin{bmatrix} B \\ D + D^T \end{bmatrix}$

hold.

Proof $3 \Rightarrow 2$: Due to Theorem 4.2, there exists a regular initial solution, say (z, x, w) . Remark 4 implies that this initial solution is a forward solution on an interval $[0, \epsilon)$ where $\epsilon = \theta(z, x, w)$. By using Theorem 6 repeatedly, we can obtain a forward solution on the interval $[0, T)$ for any $T > 0$.

$2 \Rightarrow 1$: By definition, a forward solution is a solution.

$1 \Rightarrow 3$: It follows from Remark 2 that

$$Fu(t) \in \mathcal{Q}_D^* + \text{im } C \tag{77}$$

for almost all $t \in [0, T)$. Since u is a Bohl function, the same relation must hold for all t in the given interval. The condition (76b) follows from Theorem 2, (29b–c) for $t = 0$.

i: Note that the triple $(z^1 - z^2, x^1 - x^2, w^1 - w^2)$ is a trajectory of the linear system (4) with the zero initial state. Note also that $(z^1(t) - z^2(t))^T (w^1(t) - w^2(t)) \leq 0$ for all t due to the complementarity relations (29c). Then, the dissipation inequality (5) results in

$$(x^1(t) - x^2(t))^T K (x^1(t) - x^2(t)) \leq 0 \tag{78}$$

for all t . This means that $x^1 = x^2$ since K is positive definite.

ii: Since $x^1 = x^2$, we get

$$0 = B(z^1 - z^2) \tag{79a}$$

$$w^1 - w^2 = D(z^1 - z^2). \tag{79b}$$

Clearly, $z^1 - z^2 \in \ker B$. Due to complementarity, we know that $(z^1(t) - z^2(t))^T (w^1(t) - w^2(t)) \leq 0$ for all t . By left-multiplying (79b) by $(z^1(t) - z^2(t))^T$, one gets

$$(z^1(t) - z^2(t))^T D (z^1(t) - z^2(t)) \leq 0. \tag{80}$$

Since D is nonnegative definite, this holds only if $(D + D^T)(z^1 - z^2) = 0$.

iii: This readily follows from statement ii and the relation (79b). □

Remark 7 Complementarity systems are examples of the so-called hybrid systems (see e.g. [1,20]). Very roughly speaking, a hybrid system consists of a collection of dynamical systems and a set of transition rules (see e.g. [41] for more details). At any given time instant, the behavior of a hybrid system is determined by one of the associated dynamical systems. Transition rules determine when and how the active system is going to be replaced by another. The time instants for which such a transition occurs are called event times. An interesting phenomenon that might occur is the accumulation of event times. This phenomenon called Zeno behavior in hybrid systems terminology (see e.g. [43]). It turns out that finding conditions under which hybrid systems do not exhibit Zeno behavior is rather a hard task. In the context of complementarity systems, absence of Zeno behavior is shown in [35] when D is a P -matrix. A detailed discussion of Zeno behavior is beyond the scope of this paper. Speaking very loosely, however, Theorem 7 rules out left accumulation of event times as it proves that for any solution there exists a corresponding forward solution. Moreover, right accumulation of event times can also be ruled out when D is a positive definite matrix by reversing the time and rendering the time-reversed system passive by shifting its poles (see [13] for more details).

4.6 Inconsistent initial states

The condition (76b) characterizes the set of initial states from which a ‘smooth’ continuation is possible. Such initial states are sometimes, for instance in circuit theory literature, called consistent initial states. One way of treating inconsistent initial states, i.e. states that do not satisfy (76b), is to introduce a jump in the state variable. Roughly speaking, this corresponds to, in physical systems, modeling very fast changes as if they happen instantaneously. The following theorem paves the road to introduce a jump rule in terms of the energy stored in the system.

Theorem 8 *Consider the LCS (29) such that the system $\Sigma(A, B, C, D)$ is passive. Let K be a solution of the LMIs (6) and N be such that $\mathcal{Q}_D = \text{pos}(N)$. Let $x_0 \in \mathbb{R}^n$ and $w_0 \in \mathbb{R}^m$. Suppose that the set $\{x \mid Cx + w_0 \in \mathcal{Q}_D^*\}$ is not empty. Consider the following problems:*

$$\left\{ \begin{array}{l} \text{minimize } (x - x_0)^T K (x - x_0) \\ \text{subject to } Cx + w_0 \in \mathcal{Q}_D^* \end{array} \right\} \tag{MP}_1$$

$$\left\{ \begin{array}{l} \text{minimize } x^T K x + 2w_0^T N v \\ \text{subject to } v \geq 0 \text{ and } Kx = Kx_0 + KBNv \end{array} \right\} \tag{MP}_2$$

$$\left\{ \begin{array}{l} \text{minimize } v^T N^T CBNv + 2(Cx_0 + w_0)^T N v \\ \text{subject to } v \geq 0 \end{array} \right\} \tag{MP}_3$$

$$\left\{ \begin{array}{l} v \geq 0 \\ N^T(Cx_0 + w_0) + N^T CBNv \geq 0 \\ v^T(N^T(Cx_0 + w_0) + N^T CBNv) = 0 \end{array} \right\} \tag{LCP}$$

$$\left\{ \begin{array}{l} z \in \mathcal{Q}_D \\ Cx_0 + w_0 + CBz \in \mathcal{Q}_D^* \\ z^T(Cx_0 + w_0 + CBz) = 0 \end{array} \right\}. \tag{GLCP}$$

The following statements hold:

1. The problem (MP_1) always admits a solution.
2. If a vector \bar{x} solves (MP_1) then there exists \bar{v} such that the pair (\bar{x}, \bar{v}) solves (MP_2) .
3. If a pair of vectors (\bar{x}, \bar{v}) solves (MP_2) then the vector \bar{v} solves (MP_3) .
4. If a vector \bar{v} solves (MP_3) then there exists \bar{x} such that the pair (\bar{x}, \bar{v}) solves (MP_2) .
5. If a pair of vectors (\bar{x}, \bar{v}) solves (MP_2) then there exists \hat{x} with $K\hat{x} = K\bar{x}$ such that \hat{x} solves (MP_1) .
6. A vector \bar{v} solves (MP_3) if, and only if, it solves the linear complementarity problem (LCP) .
7. A vector \bar{v} solves the linear complementarity problem (LCP) if, and only if, $\bar{z} = N\bar{v}$ solves the generalized linear complementarity problem $(GLCP)$.

Proof 1. This follows from Frank-Wolfe theorem (see e.g. [17, Theorem 2.8.1]).

2. Take $Q = 2K, b = -2Kx_0, A = 2N^T C$, and $c = -2N^T w_0$. Apply Theorem 11.2 by using Lemma 1 ii.
3. Clearly,

$$K\bar{x} = K(x_0 + BN\bar{v}). \tag{81}$$

Due to Lemma 1ii, $KBNv = C^T Nv$ for all $v \geq 0$ since $Nv \in \mathcal{Q}_D \subseteq (D + D^T)$ for all $v \geq 0$. Then, it follows from (81) that

$$\bar{x}^T K\bar{x} = (x_0 + BN\bar{v})^T K(x_0 + BN\bar{v}) \tag{82a}$$

$$= \bar{v}^T N^T CBN\bar{v} + 2(Cx_0)^T N\bar{v} + x_0^T Kx_0. \tag{82b}$$

Consequently, \bar{v} solves (MP_3) .

4. Take any \bar{x} satisfying (81). It follows from (82b) that the pair (\bar{x}, \bar{v}) solves (MP_2) .
5. Take $Q = 2K, b = -2Kx_0, A = 2N^T C$, and $c = -2N^T w_0$. Apply Theorem 11.3 by using Lemma 1ii.
6. This follows from $\mathcal{Q}_D = \text{pos}(N)$ and Theorem 11.1.
7. This immediately follows from $\mathcal{Q}_D = \text{pos}(N)$.

□

This theorem shows that the problems (MP_1) , (MP_2) , (MP_3) , (LCP) , and $(GLCP)$ are equivalent in a sense. Note that the last three of these do not depend on the storage function K . When K is positive definite, the minimization problem (MP_1) admits a unique solution.

We define the jump in accordance with this problem. Speaking in terms of the stored energy, our jump rule says that the initial state jumps to a state that is consistent and that is the closest state to the initial state in the metric defined by the stored energy.

Note that if the initial state x_0 is consistent, then the unique solution $x = x_0$. If the initial state is inconsistent, we take the solution of the problem (MP_1) as the new initial state. As it is consistent by definition, there exists a smooth continuation from this *re-initialized* state.

The state jump rule given by (MP_1) is very much akin to Jean-Jacques Moreau’s principle of maximum dissipation (see [28,29]) in the context of mechanical systems with unilateral contacts and dry friction. Also the link between complementarity systems and the quadratic programming was studied by Moreau in [27].

Theorem 9 *Consider an LCS (29) such that the system $\Sigma(A, B, C, D)$ is passive. Suppose that the LMIs (6) have a positive definite solution. Let K be such a solution of the LMIs (6). Also let T be a positive number and u be an input such that $Fu(t) \in \mathcal{Q}_D^* + \text{im } C$ for all $t \in [0, T)$. For each initial state x_0 ,*

1. *there exists a unique re-initialized state x_0^+ such that it solves the minimization problem*

$$\begin{aligned} &\text{minimize } (x - x_0)^T K (x - x_0) \\ &\text{subject to } Cx + Fu(0) \in \mathcal{Q}_D^* \end{aligned}$$

2. *there exists a forward solution (z, x, w) for the initial state x_0^+ and the input u on $[0, T)$.*

Proof This follows from Theorems 7 and 8. □

4.7 Extension to cone complementarity systems

Up to now, we have focused on the linear complementarity systems of the form (29). Clearly, these systems can be considered as a particular case of cone complementarity systems (20) by taking $\mathcal{C} = \mathbb{R}_+^m$. In this section, we extend the previous results on the LCSs (29) to (20). The following two observations make this extension possible. The first one is an equivalence relation between the LCCS (20) and a corresponding LCS (29) of the form.

Lemma 7 *Consider the LCCS (20). Let \mathcal{C} be a polyhedral cone given by $\mathcal{C} = \text{pos}(M)$ for some matrix $M \in \mathbb{R}^{m \times \bar{m}}$. Then, the following statements hold:*

1. *If a triple (z, x, w) is a (forward) solution to LCCS(A, B, C, D, E, F) then there exist functions (\bar{z}, \bar{w}) with $z = M\bar{z}$ and $\bar{w} = M^T w$ such that (\bar{z}, x, \bar{w}) is a (forward) solution to LCS(A, BM, M^T C, M^T DM, E, M^T F).*
2. *If a (\bar{z}, x, \bar{w}) is a (forward) solution to LCS(A, BM, M^T C, M^T DM, E, M^T F) then there exist functions (z, w) with $z = M\bar{z}$ and $M^T w = \bar{w}$ such that (z, x, w) is a (forward) solution to LCCS(A, B, C, D, E, F).*

Proof Note that if $\mathcal{C} = \{Mz \mid z \geq 0\}$ then $\mathcal{C}^* = \{w \mid M^T w \geq 0\}$. Then, the assertions follow by considering the LCS

$$\dot{x}(t) = Ax(t) + BM\bar{z}(t) + Eu(t) \tag{83a}$$

$$\bar{w}(t) = M^T Cx(t) + M^T DM\bar{z}(t) + M^T Fu(t) \tag{83b}$$

$$0 \leq \bar{z}(t) \perp \bar{w}(t) \geq 0. \tag{83c}$$

□

The second observation states that the mapping

$$(A, B, C, D) \mapsto (A, BM, M^T C, M^T DM)$$

preserves passivity.

Lemma 8 Consider the linear system $\Sigma(A, B, C, D)$. If K is a solution to the LMIs (6) corresponding to $\Sigma(A, B, C, D)$ then so is to the LMIs (6) corresponding to $\Sigma(A, BM, M^T C, M^T DM)$.

Proof This follows from the identity

$$\begin{aligned} & \begin{bmatrix} A^T K + KA & KBM - C^T M \\ M^T B^T K - M^T C & -M^T (D + D^T) M \end{bmatrix} \\ &= \begin{bmatrix} I & 0 \\ 0 & M \end{bmatrix}^T \begin{bmatrix} A^T K + KA & KB - C^T \\ B^T K - C & -(D + D^T) \end{bmatrix} \begin{bmatrix} I & 0 \\ 0 & M \end{bmatrix}. \end{aligned}$$

□

Theorem 10 Consider an LCCS (29) such that the system $\Sigma(A, B, C, D)$ is passive and the cone \mathcal{C} is polyhedral given by $\mathcal{C} = \text{pos}(M)$ for some matrix $M \in \mathbb{R}^{m \times \bar{m}}$. Suppose that the LMIs (6) have a positive definite solution. Let K be such a solution of the LMIs (6). Also let T be a positive number and u be an input. For each initial state x_0 ,

1. there exists a unique re-initialized state x_0^+ that solves the minimization problem

$$\begin{aligned} & \text{minimize } (x - x_0)^T K (x - x_0) \\ & \text{subject to } M^T Cx + M^T Fu(0) \in \mathcal{Q}_{M^T DM}^* \end{aligned}$$

2. there exists a forward solution (z, x, w) for the initial state x_0^+ and the input u on $[0, T)$.

Proof This follows from Theorem 9 and Lemmas 7 and 8.

□

5 Conclusions

We studied existence, uniqueness, and nature of solution of cone complementarity systems for which the underlying dynamical system is linear and passive. Necessary and sufficient conditions for existence and uniqueness of solutions are presented. We

also gave a complete characterization of initial states for which a solution exists. These states are called consistent. For the inconsistent states, we introduced a distributional solution concept. Similar results were already available under somewhat restrictive and unnatural assumptions (see [10, 13, 21, 22]). It turns out, however, that absence of these assumptions makes it impossible to use similar methods to those employed in earlier work and a completely new line of argumentation is needed. Another contribution is that all presented results hold for polyhedral cones whereas only very specific types of cones were investigated in the previous work. Extension of these results for more general classes inputs are among the first issues for further research.

6 Appendix 1: Quadratic programming

Theorem 11 *Let Q be a symmetric nonnegative definite matrix. Consider the following three quadratic programs*

$$\text{minimize } \frac{1}{2}x^T Qx + b^T x \text{ subject to } x \geq 0 \tag{QP_1}$$

$$\text{minimize } \frac{1}{2}x^T Qx + b^T x \text{ subject to } Ax \geq c \tag{QP_2}$$

$$\text{minimize } \frac{1}{2}x^T Qx - c^T u \text{ subject to } A^T u - Qx = b \text{ and } u \geq 0. \tag{QP_3}$$

The following statements hold.

1. *Karush-Kuhn-Tucker conditions*

$$\begin{aligned} x &\geq 0 \\ b + Qx &\geq 0 \\ x^T(b + Qx) &= 0 \end{aligned}$$

are necessary and sufficient for the vector x to be globally optimal solution of the quadratic program (QP_1) .

2. (Dorn's duality theorem) [25, Theorem 8.2.4] *If \bar{x} solves (QP_2) then there exists \bar{u} such that (\bar{x}, \bar{u}) solves (QP_3) . Moreover, the two extrema are equal.*
3. (Dorn's converse duality theorem) [25, Theorem 8.2.6] *If (\bar{x}, \bar{u}) solves (QP_3) then there exists \hat{x} with $Q\hat{x} = Q\bar{x}$ such that \hat{x} solves (QP_2) .*

7 Appendix 2: Geometric control theory

Consider the linear system

$$\begin{aligned} \dot{x}(t) &= Ax(t) + Bu(t) \\ y(t) &= Cx(t) + Du(t) \end{aligned}$$

where $x \in \mathbb{R}^n$, $u \in \mathbb{R}^m$, $y \in \mathbb{R}^p$, and all involved matrices are of appropriate dimensions. A subspace $\mathcal{V} \subseteq \mathbb{R}^n$ is said to be an *output-nulling controlled-invariant* subspace if there exists $L \in \mathbb{R}^{m \times n}$ such that

$$(A + BL)\mathcal{V} \subseteq \mathcal{V} \quad \text{and} \quad (C + DL)\mathcal{V} = \{0\}.$$

Since the set of all such subspaces are closed under subspace sum and intersection, there exists a unique subspace \mathcal{V}^* such that

$$\mathcal{V} \subseteq \mathcal{V}^*$$

holds whenever \mathcal{V} is an output-nulling controlled invariant subspace. We call \mathcal{V}^* the *largest output-nulling controlled invariant subspace* and define

$$\mathcal{L} = \{L \mid (A + BL)\mathcal{V}^* \subseteq \mathcal{V}^* \text{ and } (C + DL)\mathcal{V}^* = \{0\}\}.$$

The following result (see e.g. [38, Theorem 7.11]) establishes a link between such subspaces and the so-called zero dynamics of linear systems.

Theorem 12 *The pair (u, x) satisfies the differential algebraic equations*

$$\begin{aligned} \dot{x}(t) &= Ax(t) + Bu(t) \\ 0 &= Cx(t) + Du(t) \end{aligned}$$

if and only if $x(0) \in \mathcal{V}^$ and the input u has the form $u(t) = Lx(t) + v(t)$ where $L \in \mathcal{L}$, $v(t) \in \ker D \cap B^{-1}\mathcal{V}^*$ for almost all t , and $B^{-1}\mathcal{V}^* = \{\bar{v} \mid B\bar{v} \in \mathcal{V}^*\}$.*

References

1. Brogliato, B.: Some perspectives on the analysis and control of complementarity systems. *IEEE Trans. Autom. Control* **48**(6), 918–935 (2003)
2. Brogliato, B.: Absolute stability and the Lagrange-Dirichlet theorem with monotone multivalued mappings. *Syst. Control Lett.* **51**(5), 343–353 (2004)
3. Brogliato, B.: Some results on the controllability of planar evolution variational inequalities. *Syst. Control Lett.* **54**, 65–71 (2005)
4. Brogliato, B., Daniilidis, A., Lemaréchal, C., Acary, V.: On the equivalence between complementarity systems, projected systems and unilateral differential inclusions. *Syst. Control Lett.* **55**(1), 45–51 (2006)
5. Brogliato, B., Goeleven, D.: Well-posedness, stability and invariance results for a class of multivalued lure dynamical systems. *Nonlinear Anal. Theory Methods Appl.* **74**, 195–212 (2011)
6. Brogliato, B., Lozano, R., Egeland, O., Maschke, B.: *Dissipative Systems Analysis and Control: Theory and Applications*, 2nd edn. Communications and Control Engineering Series. Springer, London (2007)
7. Brogliato, B., Thibault, L.: Existence and uniqueness of solutions for non-autonomous complementarity dynamical systems. *J. Convex Anal.* **17**(3–4), 961–990 (2010)
8. Camlibel, M.K.: *Complementarity methods in the analysis of piecewise linear dynamical systems*. PhD thesis, Dissertation series of Center for Economic Research, Tilburg University, The Netherlands, 2001 (ISBN: 90 5668 079 X)
9. Camlibel, M.K.: Popov-Belevitch-Hautus type tests for the controllability of linear complementarity systems. *Syst. Control Lett.* **56**(5), 381–387 (2007)

10. Camlibel, M.K., Heemels, W.P.M.H., van der Schaft, A.J., Schumacher, J.M.: Switched networks and complementarity. *IEEE Trans. Circuits Syst. I Fundam. Theory Appl.* **50**(8), 1036–1046 (2003)
11. Camlibel, M.K., Heemels, W.P.M.H., Schumacher, J.M.: On the controllability of bimodal piecewise linear systems. In: Alur, R., Pappas, G.J. (eds.) *Hybrid Systems: Computation and Control*. LNCS 2993, pp. 250–264. Springer, Berlin (2004)
12. Camlibel, M.K., Heemels, W.P.M.H., Schumacher, J.M.: Algebraic necessary and sufficient conditions for the controllability of conewise linear systems. *IEEE Trans. Autom. Control* **53**(3), 762–774 (2008)
13. Camlibel, M.K., Heemels, W.P.M.H., Schumacher, J.M.: On linear passive complementarity systems. *Eur. J. Control* **8**(3), 220–237 (2002)
14. Camlibel, M.K., Heemels, W.P.M.H., Schumacher, J.M.: A full characterization of stabilizability of bimodal piecewise linear systems with scalar inputs. *Automatica* **44**(5), 1261–1267 (2008)
15. Camlibel, M.K., Pang, J.-S., Shen, J.: Conewise linear systems: non-zenoness and observability. *SIAM J. Control Optim.* **45**(5), 1769–1800 (2006)
16. Camlibel, M.K., Pang, J.S., Shen, J.: Lyapunov stability of complementarity and extended systems. *SIAM J. Optim.* **17**(4), 1056–1101 (2006)
17. Cottle, R.W., Pang, J.-S., Stone, R.E.: *The Linear Complementarity Problem*. Academic Press, Boston (1992)
18. Goeleven, D., Brogliato, B.: Stability and instability matrices for linear evolution variational inequalities. *IEEE Trans. Autom. Control* **49**(4), 521–534 (2004)
19. Heemels, W.P.M.H.: Linear complementarity systems: a study in hybrid dynamics. PhD thesis, Department of Electrical Engineering, Eindhoven University of Technology, Eindhoven, The Netherlands (1999)
20. Heemels, W.P.M.H., Brogliato, B.: The complementarity class of hybrid dynamical systems. *Eur. J. Control* **26**(4), 651–677 (2003)
21. Heemels, W.P.M.H., Camlibel, M.K., van der Schaft, A.J., Schumacher, J.M.: Modelling, well-posedness, and stability of switched electrical networks. In: Maler, O., Pnueli, A. (eds.) *Hybrid Systems: Computation and Control*. LNCS 2623, pp. 249–266. Springer, Berlin (2003)
22. Heemels, W.P.M.H., Camlibel, M.K., Schumacher, J.M.: On the dynamic analysis of piecewise-linear networks. *IEEE Trans. Circuits Syst. I Fundam. Theory Appl.* **49**(3), 315–327 (2002)
23. Heemels, W.P.M.H., Schumacher, J.M., Weiland, S.: The rational complementarity problem. *Linear Algebra Appl.* **294**(1–3), 93–135 (1999)
24. Heemels, W.P.M.H., Schumacher, J.M., Weiland, S.: Linear complementarity systems. *SIAM J. Appl. Math.* **60**(4), 1234–1269 (2000)
25. Mangasarian, O.L.: *Nonlinear Programming*. McGraw-Hill, New York (1969)
26. McCollum, P.A., Brown, B.F.: *Laplace Transform Tables and Theorems*. Holt Rinehart and Winston, New York (1965)
27. Moreau, J.J.: Quadratic programming in mechanics: dynamics of one-sided constraints. *SIAM J. Control* **4**, 153–158 (1966)
28. Moreau, J.J.: Liaisons unilaterales sans frottement et chocs inélastiques. *C. R. Acad. Sci. Paris Ser. II* **296**(19), 1473–1476 (1983)
29. Moreau, J.J.: Unilateral contact and dry friction in finite freedom dynamics. In: Moreau, J.J., Panagiotopoulos, P.D. (eds.) *Nonsmooth Mechanics and Applications*. CISM Courses and Lectures, vol. 302, pp. 1–82. Springer, Wien, New York (1988)
30. Pang, J.S., Stewart, D.E.: Solution dependence on initial conditions in differential variational inequalities. *Math. Program. B* **116**, 429–460 (2007)
31. Pang, J.S., Stewart, D.E.: Differential variational inequalities. *Math. Program. A* **113**(2), 345–424 (2008)
32. Rudin, W.: *Principles of Mathematical Analysis*. McGraw-Hill, New York (1976)
33. Schumacher, J.M.: Complementarity systems in optimization. *Math. Program. Ser. B* **101**, 263–295 (2004)
34. Schwartz, L.: *Théorie des Distributions*. Herman, Paris (1978)
35. Shen, J., Pang, J.S.: Linear complementarity systems: zeno states. *SIAM J. Control Optim.* **44**(3), 1040–1066 (2005)
36. Shen, J., Pang, J.S.: Strongly regular differential variational systems. *IEEE Trans. Autom. Control* **52**(2), 242–255 (2007)
37. Stoer, J., Witzgall, C.: *Convexity and Optimization in Finite Dimensions I*. Springer, Berlin (1970)

38. Trentelman, H.L., Stoorvogel, A.A., Hautus, M.L.J.: *Control Theory for Linear Systems*. Springer, London (2001)
39. van der Schaft, A.J., Schumacher, J.M.: The complementary-slackness class of hybrid systems. *Math. Control Signals Syst.* **9**, 266–301 (1996)
40. van der Schaft, A.J., Schumacher, J.M.: Complementarity modelling of hybrid systems. *IEEE Trans. Autom. Control* **43**(4), 483–490 (1998)
41. van der Schaft, A.J., Schumacher, J.M.: *An Introduction to Hybrid Dynamical Systems*. Springer, London (2000)
42. Willems, J.C.: Dissipative dynamical systems. *Arch. Ration. Mech. Anal.* **45**, 321–393 (1972)
43. Zhang, J., Johansson, K.H., Lygeros, J., Sastry, S.: Zeno hybrid systems. *Int. J. Robust Nonlinear Control* **11**, 435–451 (2001)

Copyright of Mathematical Programming is the property of Springer Science & Business Media B.V. and its content may not be copied or emailed to multiple sites or posted to a listserv without the copyright holder's express written permission. However, users may print, download, or email articles for individual use.