

Published in IET Radar, Sonar & Navigation  
 Received on 27th January 2014  
 Revised on 21st August 2014  
 Accepted on 22nd August 2014  
 doi: 10.1049/iet-rsn.2014.0041

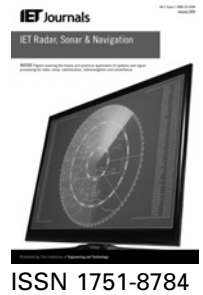

# Improvement of time difference of arrival measurements resolution by using fractional delay filters in a direct sequence-code division multiple access radionavigation system

Jaroslav Sadowski

Department of Radio Communication Systems and Networks, Gdansk University of Technology, Narutowicza 11/12, 80-233 Gdansk, Poland

E-mail: jaroslaw.sadowski@eti.pg.gda.pl

**Abstract:** This study presents a method of improving time measurements resolution in a direct sequence-code division multiple access receiver by using a fine code tracking loop based on fractional delay filtering of a despreading sequence. It briefly describes the structure of a generic digital code tracking loop and the proposed modification which allows to measure time difference of arrival values with the subsample resolution, together with suggestions to reduce computational complexity by storing the set of samples of fractionally-delayed signals in memory. The proposed solution was tested in a laboratory and in real environment in a radionavigation system built in Gdansk University of Technology.

## 1 Introduction

Most of the currently used radionavigation and radiolocation systems are based on the measurement of time of arrival (TOA) or time difference of arrival (TDOA) of radio signals. In the long wave (LW) and medium wave (MW) frequency bands the time-based radionavigation systems use narrowband signals and the time measurements relate to the envelope of transmitted pulses or a phase of a carrier signal. However, radionavigation systems with direct sequence-code division multiple access (DS-CDMA) spread spectrum signals are more popular in the VHF and UHF bands because they offer a possibility to build a single-frequency network, allow to transmit an additional data stream and are more resistant to intentional interferences. Time measurements in a DS-CDMA system are made by tracking the maximum of the crosscorrelation function of received signals and a despreading sequence in a code tracking loop. Consequently, precision of position estimation depends on the precision and resolution of this unit. The following sections present a method of increasing the time measurements resolution in a code tracking loop by introducing a fractional delay of a bandwidth-limited reference (despreading) sequence, together with results of laboratory tests and tests carried out on real signals recorded during the development of a radionavigation system for marine applications.

## 2 TDOA measurements by a code tracking loop in a DS-CDMA receiver

Let us assume that a hyperbolic radionavigation system uses DS-CDMA signals transmitted by synchronised terrestrial

base stations. Signals from at least three reference stations must be received for two-dimensional position estimation and precise timing measurements (time differences between characteristic points in the time structure of received signals) must be performed. TDOA measurements in DS-CDMA receivers are commonly made by reading differences in clocking of pseudo-random binary sequence (PRBS) generators used for despreading received signals. Synchronisation of local PRBS generators with a received signal is made by some code tracking loops which compare the results of despreading the received signal by using three locally generated PRBS sequences, shifted in time by a fraction of the chip time  $T_c$ . This method is explained in detail in various publications describing the GPS system [1], GPS receivers [2] and other applications of the CDMA technology [3]. The block diagram of a basic code tracking loop, called a delay locked loop (DLL), is presented in Fig. 1. The signal processing path presented therein and in the following figures should be doubled for  $I$  and  $Q$  components of a complex baseband signal. However, to simplify the diagrams, the other path will not be drawn. In this example, the received signal is correlated with three copies of a PRBS sequence, called 'early', 'prompt' and 'late' which are delayed by  $1/f_{\text{ref}}$ , where the reference frequency  $f_{\text{ref}}$  is  $d$  times higher than the chip frequency  $f_c$  and  $d$  usually equals 2. Value of  $d$  has to be an integer for the code tracking loop structures in which the output of a PRBS generator is binary ( $\pm 1$ ). If other sources of synchronisation errors (for example: interferences from other signals, receiver's noise) are to be neglected, the delay locked loop allows to maintain a timing error within the range of  $\pm 0.5T_{\text{ref}}$ , where  $T_{\text{ref}}$  is an inversion of the

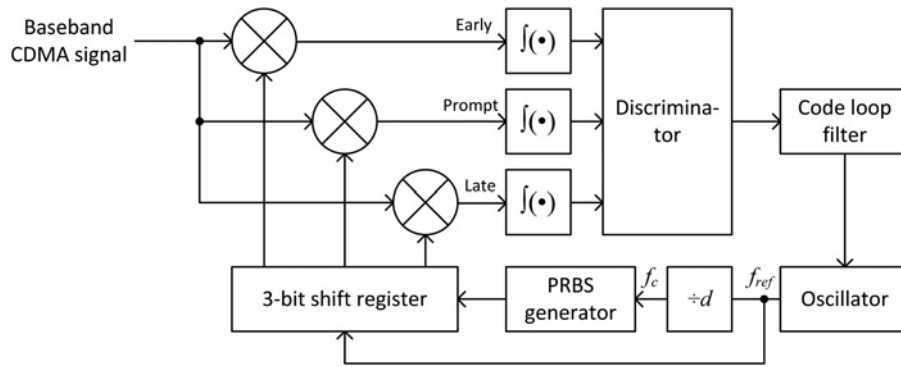

Fig. 1 Delay locked loop used to maintain synchronisation in a DS-CDMA receiver

reference frequency  $f_{ref}$  used to clock PRBS generators. The structure of the receiver required to achieve synchronisation (an acquisition phase) will not be discussed.

Although this structure is widely used as part of simplified radionavigation receivers, it has some disadvantages. It is well-suited for a continuous-time input signal and requires tuning the phase of a signal from the reference oscillator which clocks the whole loop. If a receiver has to track several not fully synchronised signals from reference transmitters, which is common in radionavigation applications because of the movement of location receivers, independent clocking of several DLLs complicates the structure of the receiver, especially in a fully digital implementation in DSP or FPGA. For such applications where the precise measurements of TOA or TDOA of received signals are crucial, all PRBS generators in all paths of a CDMA receiver should be clocked by one, not necessarily highly stable reference clock synchronised only with the input signal sampling frequency  $f_s$ . The direct conversion of the code tracking loop from Fig. 1 to the discrete-time digital structure leads to the schematic presented in Fig. 2.

The discrete-time nature of the input signal requires clocking the shift register with the sampling frequency  $f_s$ , whereas the PRBS generator needs to be clocked with the chip frequency  $f_c$ . As the output of the shift register is binary ( $\pm 1$ ), the sampling frequency  $f_s$  should be an integer multiplicity of the chip frequency  $f_c$  (integer  $d$  in Fig. 2). Even for the lowest possible  $d=2$ , the sampling frequency  $f_s = 2 \times f_c$ , which is higher than the minimum defined by the Nyquist criterion. Although the code tracking efficiency of the DLL loop from Fig. 2 is sufficient for signal

despreading and data demodulation, the resolution of time measurements in this receiver is limited to the sampling period  $T_s$ .

The time resolution of the digital code tracking loop can be improved by, for example, some curve fitting algorithms, mentioned in [2]. A constant shape of the main lobe of the input CDMA signal and a PRBS cross correlation function are assumed in the curve fitting algorithm. Integration results from the early, prompt and late correlator are then compared with main lobe shape shifted in time to obtain the best fit. The following part of this paper presents another possibility to improve the time resolution of the code tracking loop, based on fractional delay filters.

A binary despreading sequence with rectangle-shaped pulses in a digital receiver may only be shifted (delayed) in time by an integer multiplicity of the clock period (the sampling time  $T_s$ ). However, in real radiocommunication systems, received signals are bandwidth limited, so regardless of the time form of a locally generated PRBS signal, the cross-correlation function of a received signal and a despreading sequence will not have a triangle-shape form as presented in a theoretical analysis [3]. Instead, the real shape of the signal at the output of the correlator unit will resemble the one presented on the chart in Fig. 4.

For a bandwidth-limited received CDMA signal, the reference signal made of a locally generated pseudo-random despreading sequence (PRBS) may also be lowpass-filtered with the filter transfer characteristic equal to the modulation filter characteristic in a CDMA transmitter (the sum of all filtering operations in the transmitter and receiver part of a radio communication link), without losing any important part of the spectrum of the received signal. Lowpass

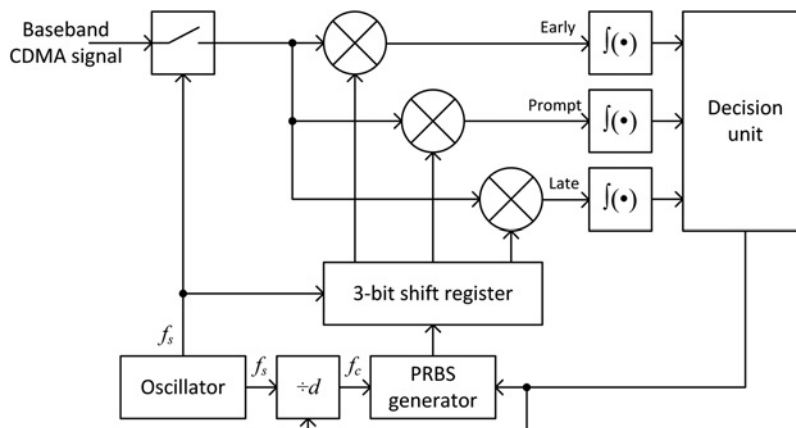
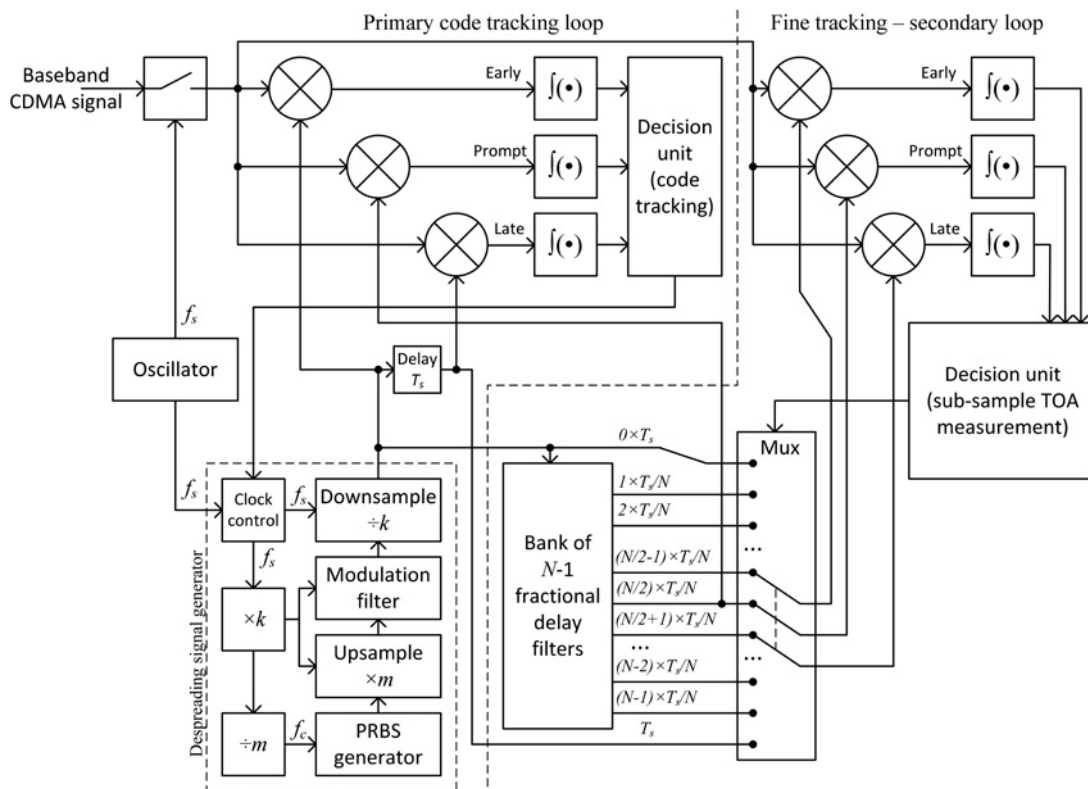

Fig. 2 Code tracking loop for the discrete-time input signal

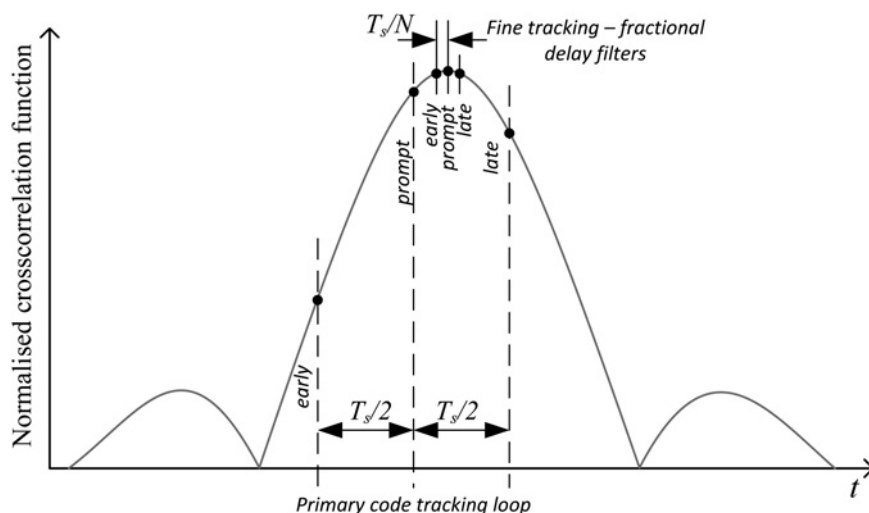

**Fig. 3** Double code tracking loop: coarse using DLL and fine with fractional delay filters

filtering changes a binary PRBS signal into a discrete-time sequence of samples that no longer have to be sampled with the frequency which is an integer multiplicity of a chip clock. If the chip frequency  $f_c$  may be written as  $f_c = (k/m) \times f_s$  where  $k$  and  $m$  are integers, then bandwidth limited samples of the PRBS signal with the  $f_s$  sampling frequency may be obtained by resampling and filtering a PRBS sequence in a compound despreding signal generator marked by the dash line on Fig. 3. The output of this signal generator is a stream of samples of the PRBS sequence with the initial phase controlled by a decision unit in the step of  $0.5 \times T_s$ .

To obtain a proper operation of the code tracking loop (marked as the primary code tracking loop in Fig. 3) which controls the phase of a despreding sequence, three

correlators are driven by a set of samples from the despreding signal generator without any delay, with a delay equal to one sampling period  $T_s$ , and with a delay equal to  $T_s/2$  introduced by a fractional delay filter. This loop allows to limit a code tracking error to the range of  $\pm 0.25T_s$ , which is enough for signal despreding and data demodulation. For radiolocation purposes, the maximum value of the cross-correlation function of a received signal may be precisely tracked by the secondary loop with the resolution of  $T_s/N$  without any change in the sampling frequency  $f_s$  which clocks almost the whole of the receiver structure (clocking of a PRBS sequence generator with  $f_c$  will be discussed later). The secondary code tracking loop uses a despreding signal with a limited bandwidth, sampled with the frequency  $f_s$ , with three



**Fig. 4** Effect of early, prompt and late correlation of the received CDMA signal in the primary and secondary code tracking loop

values of a fractional delay introduced by fractional delay filters (or an equivalent solution which will also be discussed later). The delay of fractional delay filters is controlled by a secondary decision unit, but always the ‘early’ delay is  $T_s/N$  shorter than ‘prompt’ and the ‘late’ delay is  $T_s/N$  longer than ‘prompt’. Therefore the primary loop is used to select a  $T_s/2$ -long interval, in which the maximum value of the cross-correlation function should occur by the proper clocking of a despreading sequence generator, whereas the secondary loop is responsible for refining the time period to a  $T_s/N$  long interval by a proper selection of a fractional delay of a despreading bandwidth-limited signal. Each correlation with the early, prompt and late despreading signal will give different values at the outputs of integrators, as presented in Fig. 4.

If each possible value of a fractional delay is obtained by using an independent fractional delay filter and selected on demand by a triple-output multiplexer, then for the delay range of 0 to  $T_s$  with the step of  $T_s/N$ , the total number of  $N - 1$  fractional delay filters is required, because a  $T_s$  delay may be easily implemented by a simple register. In real-life implementation some additional delay units in paths of non-filtered signals may be necessary to compensate for delays caused by causal fractional delay filters and lowpass filters. Fig. 3 presents the block diagram of the proposed double code tracking loop which uses fractional delay filters for higher resolution of time of arrival measurements.

The double code tracking loop structure, presented in Fig. 3, contains two parts with a potentially high level of computational complexity: the despreading signal generator, with resampling and filtering blocks clocked by various frequencies, and the bank of fractional delay filters. However, this complicated structure of the code tracking loop was shown just to explain the behaviour and the principle of operation of the proposed method of increasing the time measurement resolution by fractional delay filters. In the practical implementation these blocks may be easily replaced by the memory with samples of a lowpass-filtered and time shifted despreading sequence. If the following conditions are met:

- the sampling frequency  $f_s$  satisfies the Nyquist criterion for the received signal and the bandwidth-limited despreading sequence signal,
- the time period when signals in loop correlators are integrated, which is an integer multiplicity of the chip time  $T_c$ , is also an integer multiplicity of the sampling period  $T_s$ ,

then:

- the  $i$ th sample of the output signal from a despreading sequence generator may be expressed as

$$x[i] = \int_{-\infty}^{\infty} c(i \cdot T_s - \tau) \cdot h(\tau) d\tau \quad (1)$$

where  $h(\tau)$  is an impulse response of a modulation filter and  $c(t)$  is a continuous-time signal made of a PRBS sequence  $c[k]$

$$c(t) = c \left[ \left\lfloor \frac{t}{T_c} \right\rfloor \right] \quad (2)$$

- the  $i$ th sample of the output signal from  $n$ th fractional delay filter may be expressed as:

$$x_n[i] = \int_{-\infty}^{\infty} c \left( i \cdot T_s + \frac{n \cdot T_s}{N} - \tau \right) \cdot h(\tau) d\tau \quad (3)$$

where  $N$  is the number of subsample periods in one sample time.

It means that the stream of samples at the output of each filter in the structure presented in Fig. 3 is predictable and repetitive. Therefore it is possible to calculate the values of these samples in advance and store them in memory so the structure of the code tracking loop will resemble the one in Fig. 5.

Reading samples of a delayed despreading sequence from memory not only significantly reduces the computational complexity of the proposed fine code tracking loop, but also simplifies the clocking of the receiver, because the only required clock frequency is the sampling frequency  $f_s$ . Even the chip frequency  $f_c$  is no longer necessary. Sample memory also solves the delay compensation problem introduced by causal filtering, since the memory may be filled with samples of non-causal filtered signals.

### 3 Ground-based radionavigation system AEGIR

In years 2009–2011, a ground-based radionavigation system called AEGIR was designed and constructed by Gdansk University of Technology [4, 5]. This system was designed

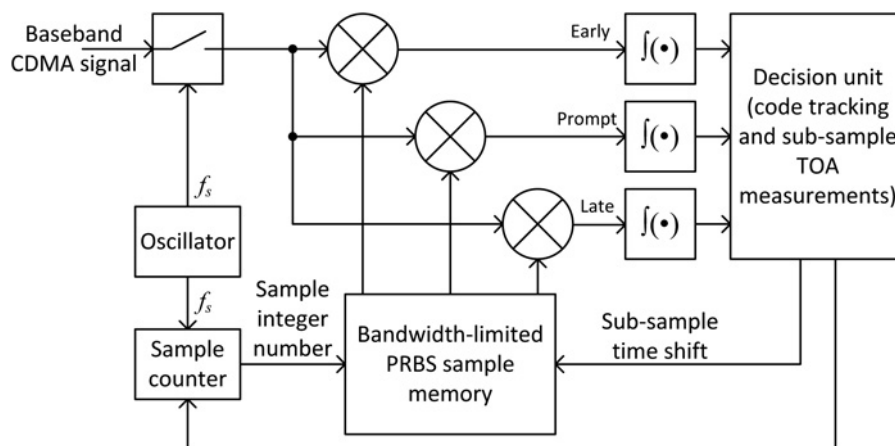

Fig. 5 CDMA code tracking loop with sub-sample resolution using a sample memory instead of a fractional delay filter bank

as a navigational aid for use on navy ships in case of unavailability of position data from other sources, such as satellite navigation systems (GPS/GLONASS). Although this research project was completed in 2011, the radionavigation system (built in the form of proof-of-concept devices) is still under development and the fine code tracking loop presented in Section 2 of this paper is one of solutions developed after the end of the project time. The AEGIR system will be briefly presented here, because a measurement campaign recording real signals from three base stations was carried out in a real-life environment during its development. The recorded signals with all effects and distortions that are caused by radio wave propagation in a marine environment in real conditions were suitable to test the proposed fine code tracking method. Therefore a test software, prepared to verify the proposed timing measurements method, and a system emulator in a laboratory were adapted to work with the CDMA signals the structure of which was identical to the AEGIR system.

A prototype of the AEGIR radionavigation system consists of three reference (base station) transmitters and one mobile receiver. Fig. 6 presents the structure of the tested prototype. The location unit is passive (reception only), so the number of possible mobile receivers in this system is unlimited. All base stations transmit QPSK-modulated signals on a common carrier frequency using a CDMA technique. Reference transmitters are not synchronised (they are clocked by free running rubidium frequency sources), so in order to allow location estimation based on time difference of arrival (TDOA) measurements, at least one reference station has to be able to receive signals from other stations, measure time differences between characteristic parts in these signals and then transmit the time differences data to a location receiver [6]. The reference station which is able to receive signals from other stations will be called 'Full reference station', whereas 'Simplified reference stations' are made only of a DS-CDMA transmitter, without the receiving part. It is obvious that in real conditions more than three reference stations may be needed to cover the whole area of operation (e.g. a coastal zone of one country), but to offer a location service the receiver has to be able to receive signals from at least three stations, while at least one of them must be the full reference station. Further

details about the structure and the principle of operation of the AEGIR system may be found in [4, 5].

### 3.1 Structure of a DS-CDMA signal

All reference stations simultaneously transmit two kinds of data packets in a continuous stream: primary location data (PLD) and extended location data (ELD) using  $I$  and  $Q$  bits in QPSK modulation. PLD packets in all reference stations contain information about the location of a transmitter and signal parameters. ELD from the full reference station contain information about time differences between signals transmitted from different stations, whereas the ELD from the simplified reference station is just a copy of the PLD data. Both data packets are divided into 26-bit fragments separated by 13-bit synchronisation fields (Barker sequence), which creates a 39-bit elementary frame structure [7]. All data and sync bits in the elementary frame are spread by a 1024-chip long fragment of a pseudo-random sequence (39 936 chip total length), different for all base stations and different for the PLD and ELD data. The data rate is equal to 1 kb/s. The format of data in transmitted streams, channel coding and data encryption are not important for timing measurements made by using the code tracking loop and will not be described here.

The contents of radio packets transmitted by the AEGIR transmitters and recorded during tests in a real environment in 2010 are now worthless, but the TDOA measurements made with the code tracking loop are data-independent, so regardless of the content of data fields, the signals recorded during those tests may be used to verify a new concept of fine timing measurements by offline processing using new algorithms. Therefore, the following description of the TDOA calculations is related to the behaviour of the DS-CDMA hyperbolic radiolocation system in the present stage of its development, not at the time of the measurement campaign in 2010.

The base station transmitters in the AEGIR system are not synchronised, so the position estimation of a mobile receiver slightly differs from the methods used in typical hyperbolic systems. Two values of timing differences for every elementary frame (39 ms long, 39 936 chips) are calculated from the signal recorded by a receiver in the full reference

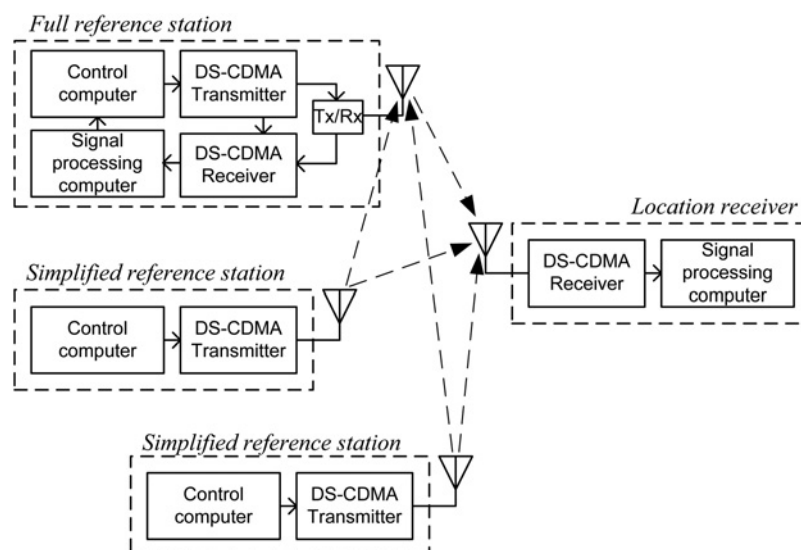

Fig. 6 Concept of the AEGIR radionavigation system

station:  $t_{10}^T[n]$  – the difference between timing of a signal from first simplified reference station and a signal from the own transmitter of the full reference station numbered 0,  $t_{20}^T[n]$  – the difference between timing of a signal from second simplified reference station and a signal from the own transmitter of the full reference station. The receiver in a mobile unit (ship) can measure (from the signals recorded during measurements)  $t_{10}^R[n]$  and  $t_{20}^R[n]$  – the difference between timing of a signal from first simplified reference station (or second simplified station, respectively) and the full station, where  $n$  is an elementary frame number (frames are numbered by a transmitter in the full reference station). The receiver in the full reference station calculates four coefficients of linear approximation of  $t_{10}^T$  and  $t_{20}^T$  based on the data from the last 90 sec of measurements using the least squares method

$$\begin{aligned} dt_{10}[n] &= a_{10} \cdot n + b_{10} \simeq t_{10}^T[n] \\ dt_{20}[n] &= a_{20} \cdot n + b_{20} \simeq t_{20}^T[n] \end{aligned} \quad (4)$$

These coefficients are periodically sent to the location receiver in an ELD data stream from the full reference station. Then the receiver in a mobile unit can calculate the real values of time differences of arrival of signals from base stations using equations

$$\begin{aligned} \text{TDOA}_{10}[n] &= t_{10}^R[n] - dt_{10}[n] - \frac{\sqrt{(X_1 - X_0)^2 + (Y_1 - Y_0)^2}}{c} \\ \text{TDOA}_{20}[n] &= t_{20}^R[n] - dt_{20}[n] - \frac{\sqrt{(X_2 - X_0)^2 + (Y_2 - Y_0)^2}}{c} \end{aligned} \quad (5)$$

where  $X_0, Y_0, X_1, Y_1, X_2$  and  $Y_2$  are Cartesian coordinates of base stations and  $c$  is the propagation speed of radio waves. Finally, the mobile receiver is able to calculate its own position using the Chan's algorithm [8].

### 3.2 Measurement campaign under real conditions

Radionavigation signals received by the full reference station and by a mobile receiver moving in the area of Gulf of Gdansk (Baltic Sea) were recorded during measurements in real conditions. The location of reference stations and the route of the motorboat with a mobile receiver during measurements is presented on map in Fig. 7. Parameters of the signals transmitted by the reference stations are summarised in Table 1.

All transmitters were clocked by rubidium frequency sources, while receivers worked only with internal crystal oscillators. Reception bandwidth was set to 1 MHz. After demodulation, the baseband signals  $I$  and  $Q$  in the receiver were sampled with the frequency of 1.28 MHz using A/D converters with 14 bit resolution. The power of the received signals was not lower than  $-95$  dBm, which was far above the noise level, so the main source of signal degradation were the own interferences from other stations, working in the same time. The differences between the power of the signals received from different stations reached 35 dB, whereas the CDMA receiver algorithms implemented in the software were only able to decode signals with power differences up to 28 dB, using multiuser detection by successive interference cancellation. As a result of all limitations, only 150 000 successful location measurements were collected during 12 h of signal recording.

## 4 Laboratory equipment

An emulator of radionavigation signals from three reference stations was built in a laboratory in order to measure characteristics of the implemented CDMA receiver with the fine code tracking loop, regardless of propagation phenomena. The block diagram of this emulator is presented in Fig. 8. A set of baseband  $I/Q$  samples is sent to the arbitrary waveform generator AFQ100 clocked by the same rubidium reference generator which was used in the

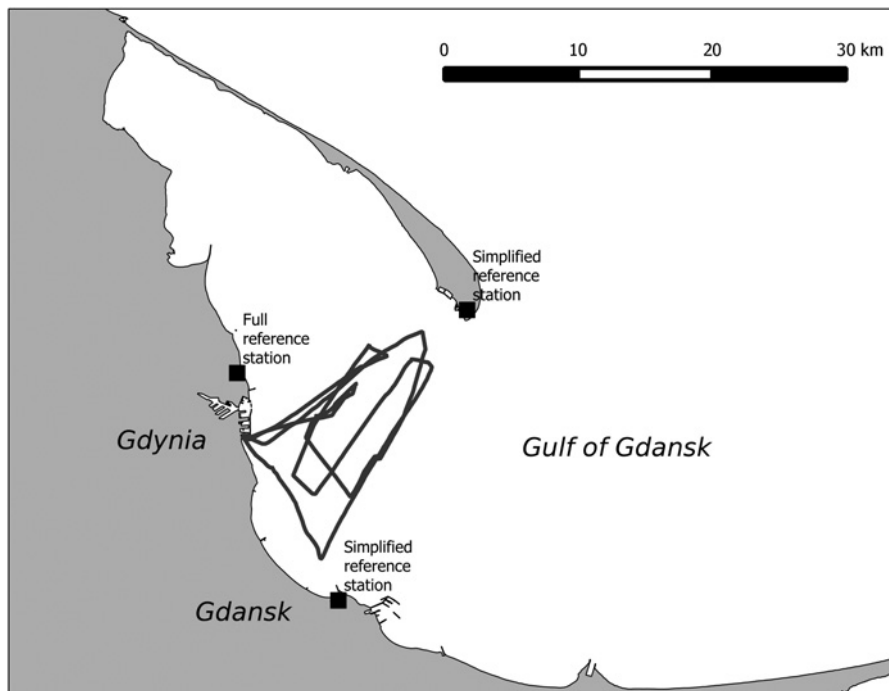

Fig. 7 Measurement path and location of reference transmitters in the area of Gulf of Gdansk

**Table 1** Parameters of the signals transmitted during measurements in real conditions

| Parameter         | Value                                     |
|-------------------|---|
| carrier frequency | 431.5 MHz                                 |
| TX output power   | 30 W                                      |
| TX antenna gain   | 2 dBi (omnidirectional)                   |
| TX antenna height | 27 to 45 m a.s.l.                         |
| bit rate          | 1000 bits/s                               |
| chip rate         | 1 024 000 chips/s                         |
| spreading factor  | 1024                                      |
| modulation        | QPSK                                      |
| modulation filter | square root-raised cosine, $\beta = 0.22$ |

base stations during measurements in the area of Gulf of Gdansk. The vector signal generator SMBV100 acts as a quadrature modulator. The emulator is controlled by the dedicated software which allows to generate CDMA signals with the structure exactly the same as in AEGIR signals, with the possibility to emulate almost any position of base stations (limited by ambiguity of PRBS sequences with a 39 ms repetition period), any position of a receiver and almost any relation of power of transmitted signals (limited by a 16-bit DAC dynamic range). The frequency offsets of transmitted signals and the Doppler shift for measurements in motion may also be emulated.

The structure of location receiver hardware during all laboratory tests was exactly the same as during measurements in real conditions in 2010. The signals recorded in a laboratory and during the tests in the area of Gulf of Gdansk were processed using software with the fine code tracking loop from Fig. 5.

## 5 Data analysis

### 5.1 Laboratory tests

The AEGIR signals emulator was used to generate signals from three reference stations. The time and power relations between components of a compound signal emulated positions of reference transmitters during measurements in a real environment and 900 different positions of the location receiver in the centre of the area covered by the measurement path presented in Fig. 7. The time structure of the transmitted signals was perfectly known, the values of  $t_{10}^T[n]$  and  $t_{20}^T[n]$  in the (4) were constant and the power of signals at the input of the EM550 receiver was at least 30 dB above the noise level. As a result, the only significant source of TDOA measurement errors (and location estimation errors of the mobile receiver) was the imperfect

time measurement using the proposed code tracking loop with fractional delay filters in a software CDMA receiver.

Signals recorded by the CDMA receiver were processed by the fine code tracking loop with different time resolution:  $T_s/5 = 156$  ns,  $T_s/10 = 78$  ns and  $T_s/50 = 16$  ns ( $N = 5, 10$  and  $50$ , respectively) where  $T_s$  is an inversion of the sampling frequency  $f_s$  (1.28 MHz). The charts in Fig. 9 present the results of processing almost 700 000 data sets: the probability density function of TDOA measurements (5) error and the cumulative distribution function of location estimation error. The spread of TDOA measurement errors in Fig. 9 matches the time resolution of the fine code tracking loop.

### 5.2 Real data from Gulf of Gdansk

Compared with laboratory tests, the number of possible sources of TDOA measurement errors in a real environment is much higher and includes

- errors of timing measurements in the full reference station:  $t_{10}^T[n]$  and  $t_{20}^T[n]$  causing imperfect linear approximation of time differences using (4),
- multipath propagation, depolarisation of the signal reflected from the water surface and the Doppler spread causing fast fading of received signals,
- errors of timing measurements in the location receiver.

It should be mentioned that the location of the mobile receiver during measurements in the area of Gulf of Gdansk was recorded using the dual system GPS + GLONASS receiver with accuracy in the order of 0.6 m. All coordinates of the receiver calculated from TDOA measurements by using the Chan's algorithm were compared with the coordinates from the satellite navigation receiver. In summary, the charts in Fig. 10 present the effects of all errors caused by: the full reference station receiver, the mobile receiver, propagation of signals in the radio channel and the satellite navigation receiver. Fig. 10a presents probability density of errors of TDOA measurements with different time resolution of the fine code tracking loop and Fig. 10b presents the cumulative distribution function of position estimation errors in real conditions in the area of Gulf of Gdansk. As a reference, the results of data processing using the digital code tracking loop without fractional delay filters (Fig. 2) with four samples per chip ( $f_s = 4.096$  MHz) [4, 5] are also presented in Fig. 10.

The real data analysis proved that the proposed implementation of the fine code tracking loop with the

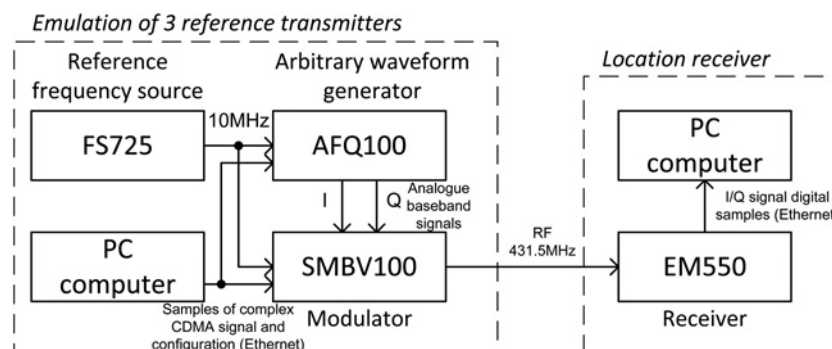
**Fig. 8** AEGIR signals emulator for laboratory tests

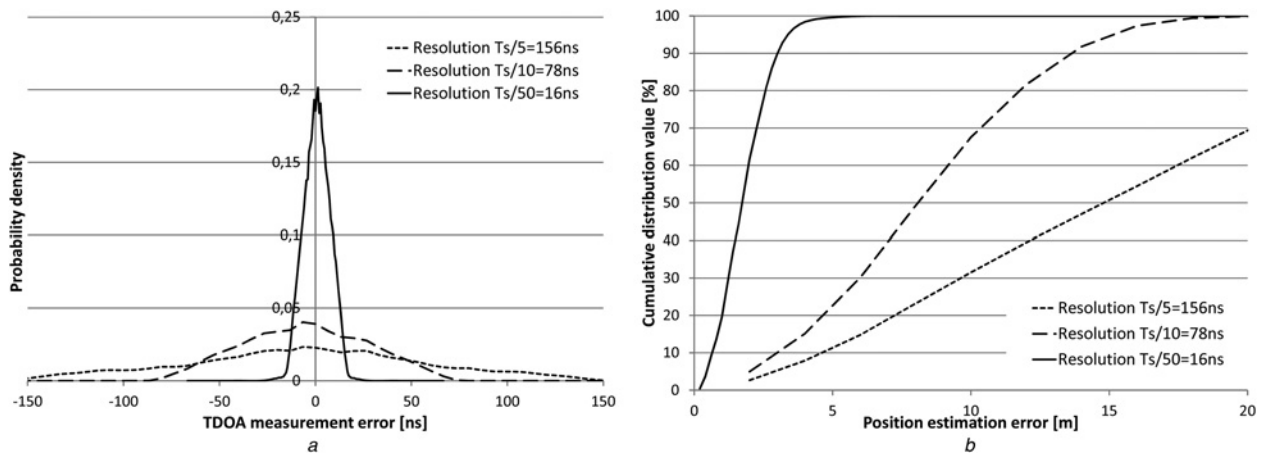

**Fig. 9** Results of fine code tracking loop laboratory tests with different time measurement resolution using the CDMA signal emulator

a Probability density function of TDOA measurement error  
b Cumulative distribution function of position estimation error

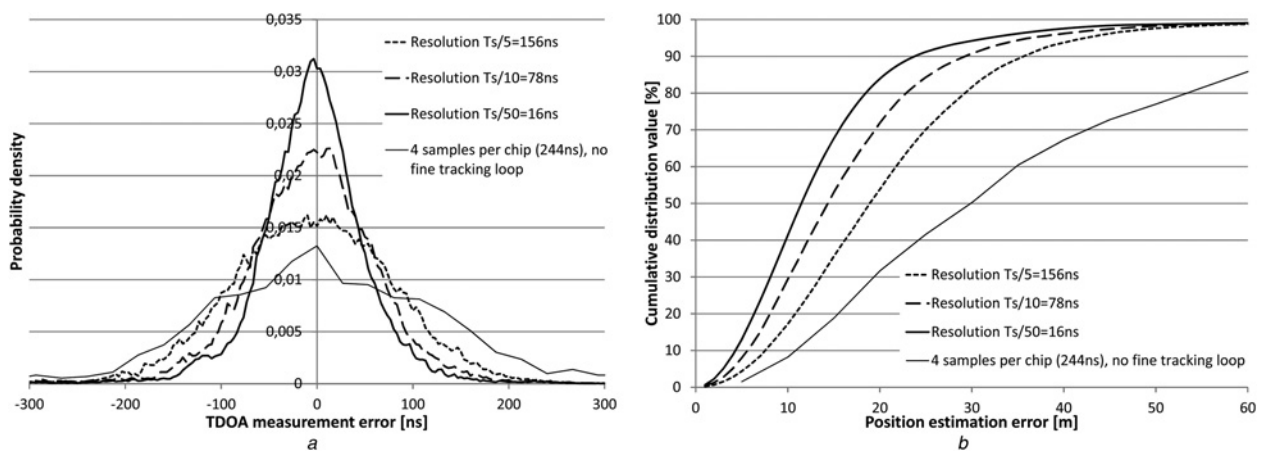

**Fig. 10** Results of the fine code tracking loop tests with different time measurement resolution in a real environment

a Probability density function of TDOA measurement error  
b Cumulative distribution function of position estimation error

memorised samples of limited bandwidth fractionally delayed despreading sequences from Fig. 5 allows to achieve a sub-sample time measurement resolution without the need to increase a sampling frequency. Even the simplest tested fractional delay filter-based code tracking loop with four fractional delay filters ( $N=5$ ) and the sampling frequency 1.28 MHz allowed to achieve better location accuracy than a generic digital implementation of the code tracking loop with a sampling frequency 4.096 MHz: in 50% of all measurements the position error was reduced from 30 to 19 m. The results for a higher-resolution code tracking loop with  $N=50$  are even better: the position error is not higher than 13 m in 50% of all results. Increasing the number of fractional delay filters to over 50 is not recommended in the tested marine radiolocation system because the accuracy of position estimation in that application is limited by properties of the radio waves propagation channel.

It is worth noting that none of the position-filtering algorithms were applied to the presented results of position estimation from TDOA measurements and the position of the mobile receiver was estimated independently every 39 ms (every elementary frame). In a real application the commonly used Kalman filtering may improve position estimation by taking into account the limited motion dynamics of located objects (ships).

## 6 Conclusion

The fine code tracking loop, presented in Section 2, allows us to improve the resolution of timing measurements in a CDMA receiver for radiolocation and radionavigation purposes without the need to increase a sampling frequency much over the Nyquist criterion. The proposed solution was tested with signals recorded by the experimental radionavigation system AEGIR during measurements in the area of Gulf of Gdansk and proved its usefulness in real conditions.

## 7 References

- 1 Kaplan, E.D.: 'Understanding GPS—principles and applications' (Artech House, 1996)
- 2 Tsui, J.B.Y.: 'Fundamentals of global positioning system receivers: a software approach' (Wiley, 2000)
- 3 Groe, J.B., Larson, L.E.: 'CDMA mobile radio design' (Artech House, 2000)
- 4 Ambroziak, S., Katulski, R., Sadowski, J., Siwicki, W., Stefański, J.: 'Asynchronous and self-organizing radiolocation system—AEGIR'. Proc. 2011 IEEE Int. Conf. on Technologies for Homeland Security, Waltham, USA, 2011, pp. 419–425
- 5 Ambroziak, S., Katulski, R., Sadowski, J., Siwicki, W., Stefański, J.: 'AEGIR—Asynchronous radiolocation system'. Proc. The Eight Int. Conf. on Wireless and Mobile Communications, Venice, Italy, 2012, pp. 103–109



- 6 Katulski, R., Stefanski, J., Siwicki, W., Sadowski, J., Ambroziak, S.: 'Asynchronous system and method for estimating position of persons and/or objects'. European patent application 11460023, 2011
- 7 Stefanski, J., Ambroziak, S., Katulski, R.: 'Demonstrator technologiczny szerokopasmowego łącza bezprzewodowego z widmem rozproszonym dla potrzeb sieci ad-hoc (in Polish)'. Research Report, Gdansk University of Technology, Gdansk, Poland, 2011
- 8 Chan, Y.T., Ho, K.C.: 'A simple and efficient estimator for hyperbolic location', *IEEE Trans. Signal Proc.*, 1994, **42**, (8), pp. 1905–1915

Copyright of IET Radar, Sonar & Navigation is the property of Institution of Engineering & Technology and its content may not be copied or emailed to multiple sites or posted to a listserv without the copyright holder's express written permission. However, users may print, download, or email articles for individual use.