

# Design of an Economical and Mechanically Stable E-Cycle

A. Sharan

*The greenhouse effect, and air pollution that our societies are facing, require immediate solutions. Among the vehicles available to-day for transportation, many are gas guzzlers. This results in excessive fossil fuel consumption, and consequently, high amounts of CO<sub>2</sub> and other poisonous gases are released in the environment. So far, the alternate electric vehicles which are free from this problem, are too expensive for the consumers. However, there are some other problems associated with these vehicles such as - Range in kilometers per charge.*

*Two new electric vehicle have been designed to overcome some of the problems mentioned above. First of all, it is economical and easily affordable in any country of the world for common masses. Their fuel consumption, in dollars or any other currency, the cost is 16 % approximately that of gasoline based vehicles. They have high acceleration. These have a minimum range of approximately 35 kilometer per charge, with a possibility of increasing the range by incorporating more batteries. One of these has a solar panel mounted on its top which supplements the electric energy during the day while the vehicle is in use. This way, its range is increased.*

---

## 1. Introduction

Different parts of the world use different modes of transportation. With rising population, the demand for fossil fuels has increased due to various reasons. One of these reasons is the transportation. In the majority of the countries in the past, people lived in the villages, so they did not have to travel very far every day. Now a days, vast number of people have moved to the cities where they have to commute long distances. Consequently, whichever vehicle they use, the need for the fuel will give rise to higher consumption of fossil fuels. Unfortunately, this fuel (gasoline) has caused massive pollution problems in most of the countries of the world. Secondly, in majority of the countries, the increase in the number of vehicles has created a demand for wider roads to accomodate these many vehicles. Building roads is expensive, even if capital and space are available. Thirdly, in the vast majority of the countries, motor cycles or scooters are being used for transportation. These vehicles mainly have two cylinder gasoline engines, which are

extremely polluting, and also, two wheelers are dangerous to use due to mechanical instability.

The objective of this work is to provide economical, non polluting, and mechanically stable vehicles which requires less road spece, and less cost of the fuel. Since the energy consumption of this designed vehicle is optimized, it can reduce the pollution of the planet or those of the cities where it can be used.

## 2. Construction Details And Operation Of The Vehicles

### 2.1 Vehicle Number 1

The designed and fabricated cycle is shown in Figs. 1A and 1B. It has three wheels to provide mechanical stability which is necessary for safety purposes. All electric bi-cycles have a serious problem of mechanical instability due to the weight of the batteries. It is well known that even gasoline powered two wheelers which do not have batteries, are not safe to ride, and quite often, the injuries to the riders are of very serious nature. Even small children ride these

bikes with their parents in many countries. Under such situations, it is imperative that to promote these electric bikes, one has to come up

with a safer design of these kinds of transportation systems.

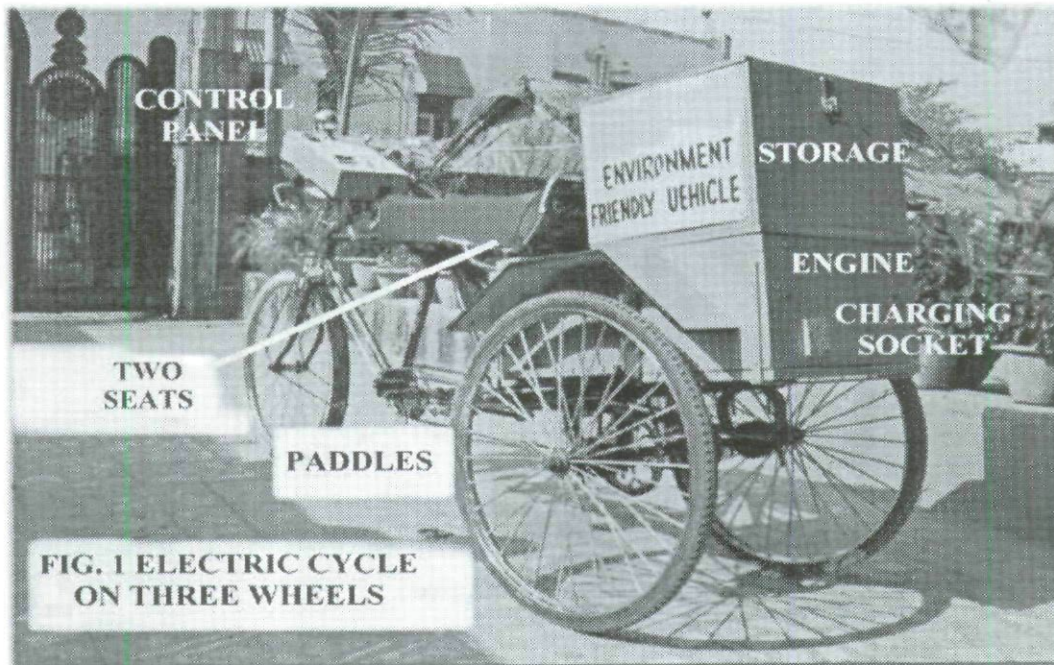

FIGURE 1: Electric Cycle on Three Wheels

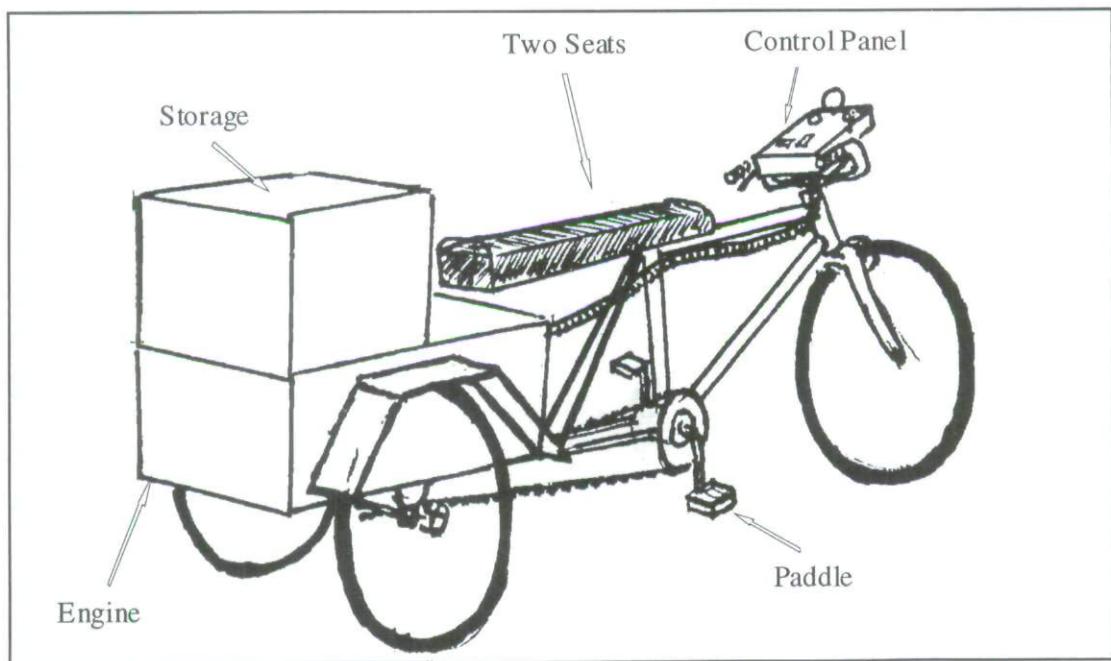

FIGURE 1B: A Sketch of the Electric Vehicle



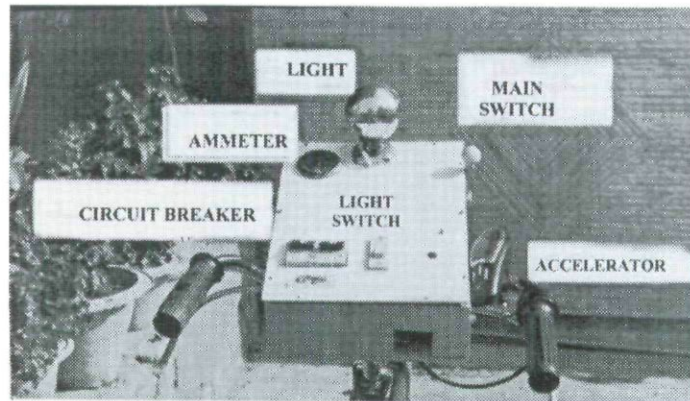

FIGURE 2A: Controls of the Electric Vehicle

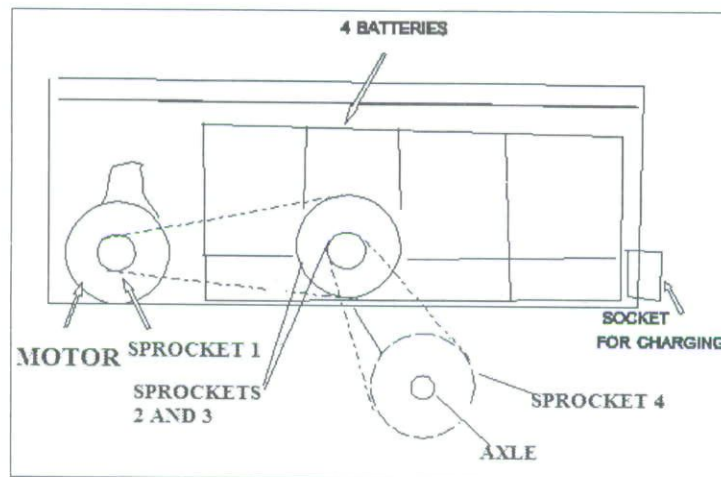

FIGURE 2B: Side View Showing Transmission

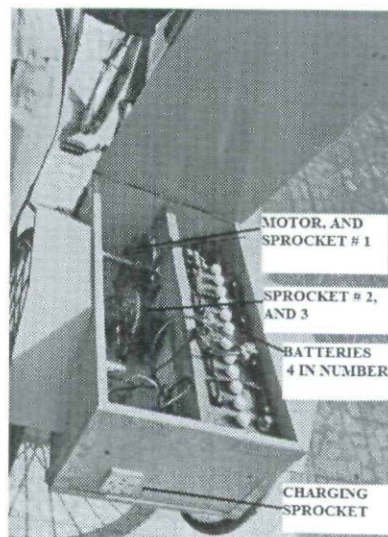

FIGURE 2C: A View Inside the Engine

This vehicle shown in Fig. 1, has two seats, and also has storage capacity for carrying any goods purchased while shopping. In majority of the countries in the world, one vehicle like this would be sufficient for a family.

The charging of the batteries is done by plugging from the back of the vehicle. The control panel is mounted at the handle bar (refer to Fig. 2A). On this panel, there are circuit breakers, ammeter for measuring current, the front light, the main switch, and a set of Light Emitting Diodes (LED) which glow when the motor is on (not shown in this figure). These

The speed control is done by two methods - the first one manually by operating a switch which is a modification of a solenoid switch used for starter motors. This switch is turned on or off by a cable connected to the accelerator shown. The mechanism of switching on or off is similar to that of a gasoline powered motor cycle. The acceleration control in this vehicle is similar to a Pulse Width Modulation (PWM) process but it is done mechanically here. The circuit diagram of this manual control is shown in Fig. 3. Here, the electric motor provides the motion through mechanical two stage speed reduction using sprockets and chains (see Figs. 2B and 2C). The power transmission from the motor is done through the chain - sprocket drive. The sprocket number 1 (16 teeth) is mounted on the motor shaft, and drives sprocket number 2 (48 teeth). Again, sprocket number 3 (16 teeth) drives the last sprocket - number 4 mounted on the axle of the vehicle. This sprocket has 48 teeth. This gives rise to two stage speed reduction of 3 each. Thus, the motor rotates at 9 times the speed of the axle. The sprockets 2 and 3 are mounted on a shaft supported by bearings at its two ends housed in pillow blocks.

The selection of the motor, and the literature on speed control can be seen in [Guru, and Hiziroglu, 1988; Hubert, 1998; and Kenjo, 1990].

The second method of speed control is using electronic speed controller which was tested in the university laboratory in St. John's Canada. It was using PWM principle. The circuit

diagram of this method is given in Fig. 4. The details about the components are shown in Table 1. This controller is meant to be used as a Power Assistance controller for vehicles which can be paddled. By incorporating more MOSFETS in parallel as shown in Fig. 4, one can control speeds of vehicles which require higher currents (greater horse power motors). In this present form, it can be used at cruising speeds with light paddling.

The circuit uses two timers/oscillators connected as a Pulse Width Modulator (PWM). One of the timers (LM556a) is configured as an oscillator and the second (LM556b) is configured for pulse width modulation. It is triggered with the pulse train from the first timer. The output on Pin 9 is a continuous stream of pulses whose width is controlled by the voltage level applied via the R5/R7/R6 Speed Control circuitry. This modulated output drives, 5 in number, the IRF630's (Field Effect Transistor (FET), which are connected in parallel in order to supply the necessary current to drive the motor.

The maximum ON time of the output pulse and therefore, maximum motor speed, can be set by changing the value of potentiometer R7. Increasing the value lowers the maximum motor speed.

The LM324 network is set up as a comparator so that when the voltage at Pin 3 drops below the set value at Pin 2, then the output from the LM324 resets the timer causing the motor to stop at very low speeds.

## 2.2 Fuel Cost Comparisons Between A Gasoline And An Electric Vehicle

The maximum current of the motor was 120 Amps at the voltage of 12 Volts. This results in the maximum power required equal to  $120 \times 12 = 1440$  Watts (1.930 horse power). In terms of energy consumption, an hour use of this vehicle will require an energy of 1.440 kWhr. The cost of electricity in Canada is 6 cents per kWhr. So, for an hour ride (30 km distance) would cost this much. In India, the cost of electricity is Rupees 4 (11 cents Canadian) per kWhr, and the gasoline costs Rs 40 (\$1.10) per litre. The fuel consumption for a scooter is 35 km/litre. The



cost of gasoline using scooter for 30 km would be:  $(30 \times 40)/35 = 34.28$  Rupees whereas for this electric vehicle, it would be  $4 \times 1.440 =$  Rupees 5.76. This cost amounts to  $(5.76 \times 100)/34.28 = 16.8\%$  of the cost of gasoline use.

In large number of under-developed countries, the average speed of the vehicles within a city is about 30km/hour. So, this electric vehicle would serve the need, and the cities would be pollution free, which is very important.

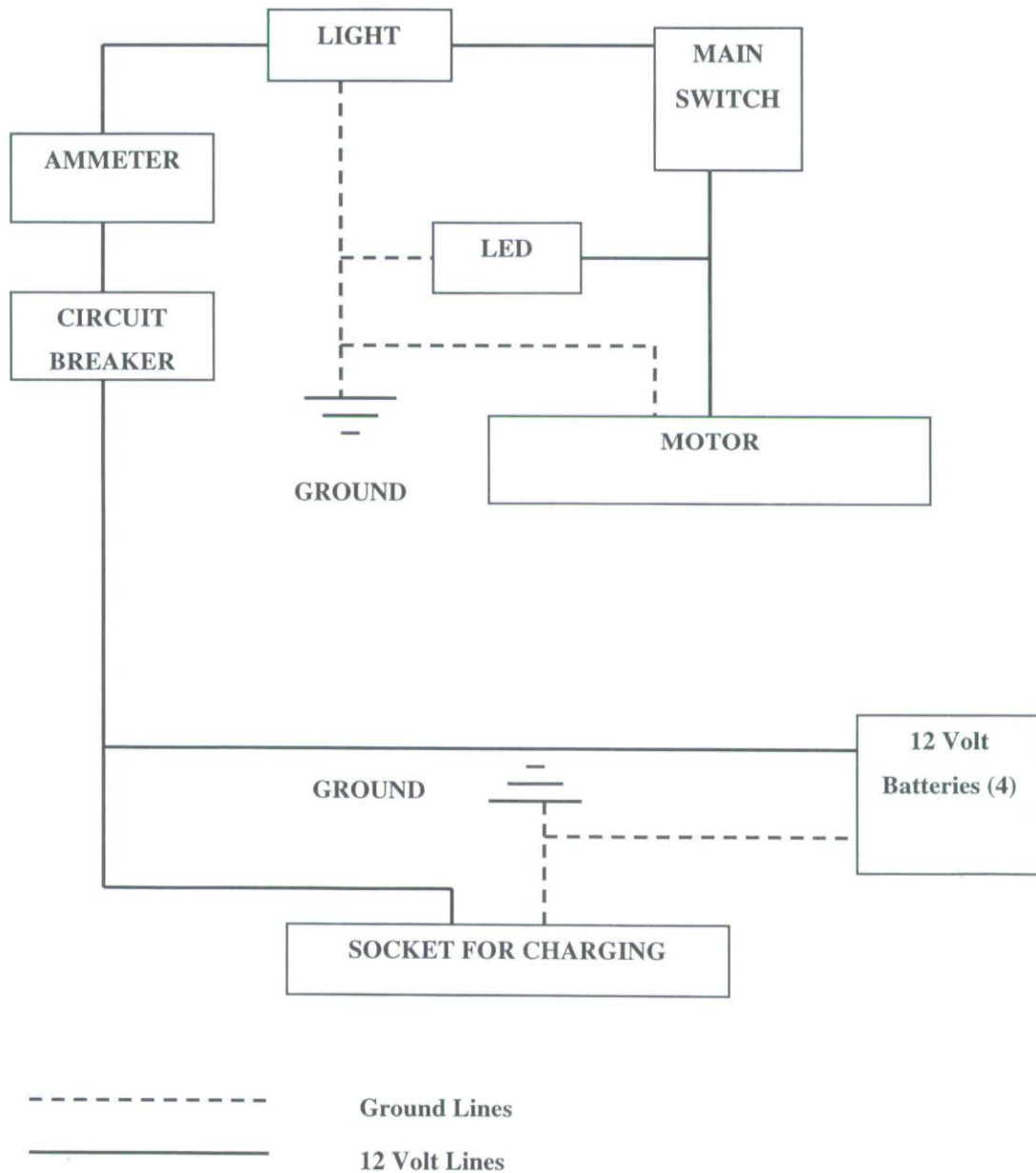

FIGURE 3: Circuit Diagram of 12 Volt Electrical System

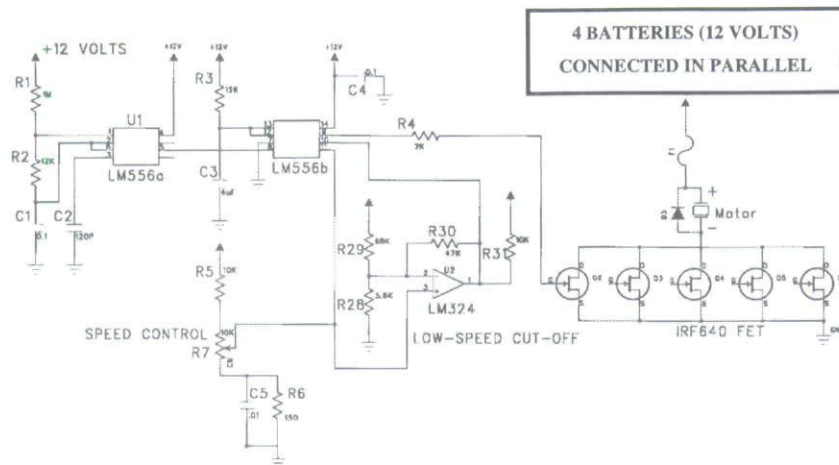

FIGURE 4: Circuit Diagram for the Speed Control at 12 Volts

TABLE 1: Parts List for Figure 4

PART DESCRIPTION	VALUE	PART DESCRIPTION	VALUE
R1	1.0 MOhm	C1	0.1 micro-F
R2	12 KOhm	C2	120 pico-F
R3	12 KOhm	C3	4 micro-F
R4	2 KOhm	C4	0.1 micro-F
R5	10 KOhm	C5	0.01 micro-F
R6	150 K Ohm	U1	LM556 Dual Timer
R7	10 KOhm pot	U2	LM324 Comparitor
R29	68 KOhm	D3	1N1752
R28	5.6 K Ohm	FET ( 5 Quantity )	IRF630
R30	47 K Ohm	F1 ( Fuse )	5 Amps
R31	10 K Ohm	Motor	12 V 120 Amps



FIGURE 5A: Solar Powered Electric Vehicle

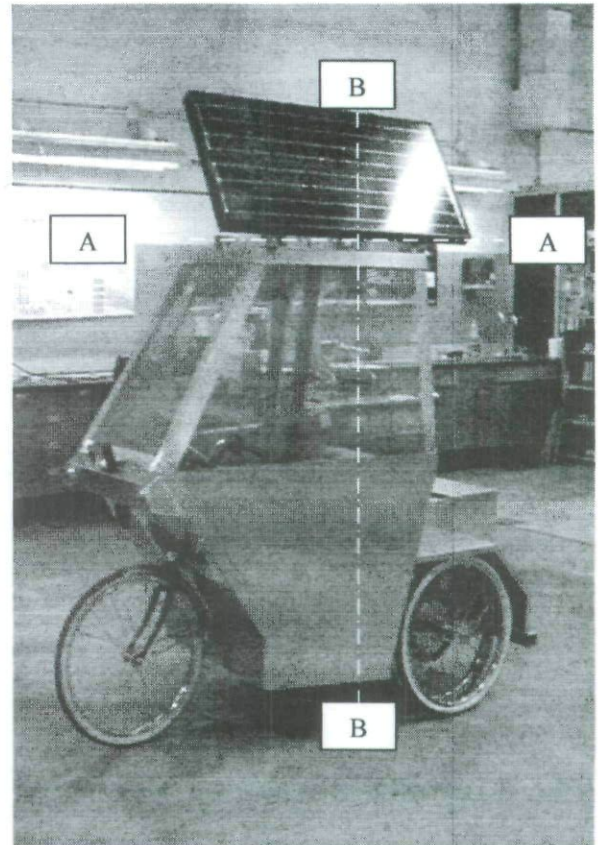

FIGURE 5B: The Horizontal and Vertical Axes

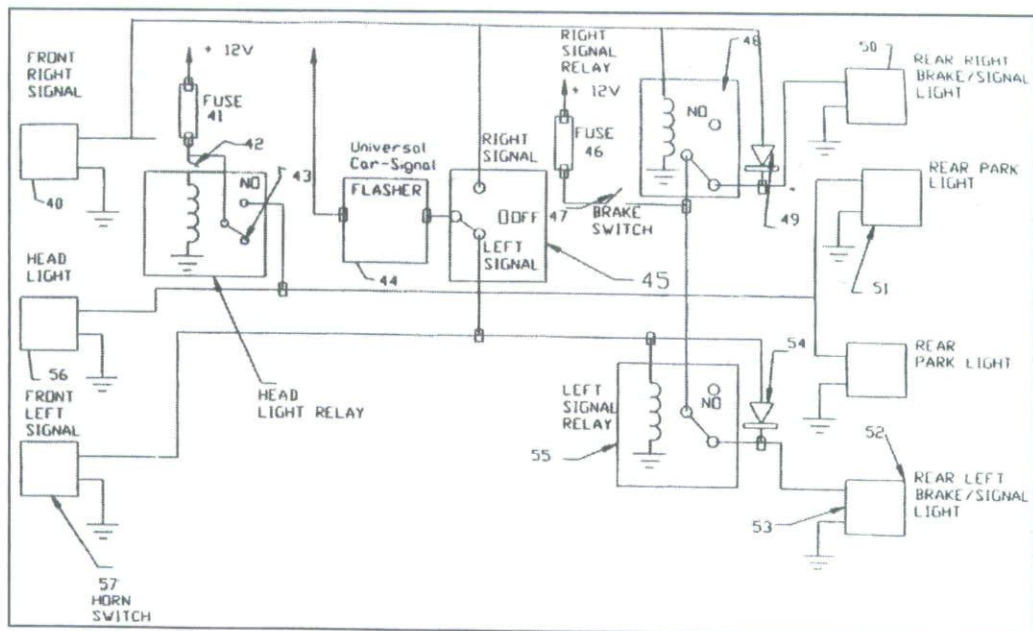

FIGURE 6: Circuit Diagram for Vehicle Lighting System



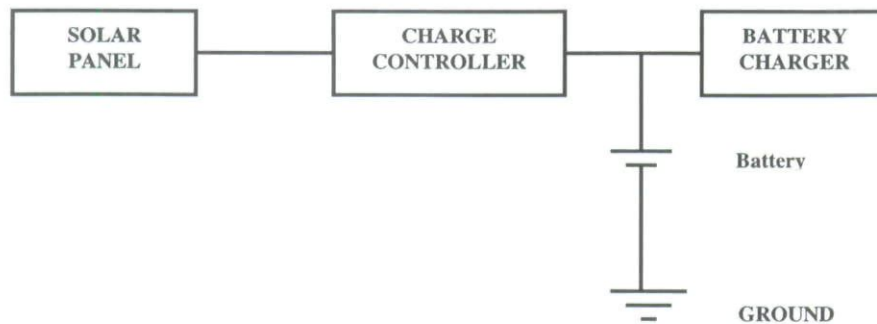

FIGURE 7: Charging of the Battery by Solar Panel and Battery Charger

### 2.3 Mechanical Paddling

In addition to the use of the motor in this vehicle, paddling provides an alternate means of energy saving. By using any combination of mechanical effort, and electrical form of energy, one can save much more fossil fuel, and the environment can be clean. For appropriate speed reduction, and torque control, one can refer to [Henderson, and Haynes, 1993; Norton, 1998; and Shigley, and Mitchell, 1983].

The maximum speed attainable by this vehicle was 30 kilometers per hour, and its range was about 35 km when four 55 amp - hour batteries were used. The cost of the vehicle was around \$800. 00 (Canadian). The vehicle had a provision of using 4 such batteries at a time.

The vehicle could be charged over-night, and normally, it needed charging 2 to 3 times in a week for a common family living in a reasonable size city.

This vehicle was built in India in the city called Patna which is the capital of state of Bihar. The Municipal Corporation gave license for the vehicle to be used on the roads. They were quite concerned over the pollution in the city.

The structure of the vehicle was special and it was made up of parts available locally. The vehicle was made of components which were much stronger than those of ordinary cycle.

This was because, the load carried in this vehicle is much more than an ordinary cycle and also the speed is much more.

This electric vehicle was quite different from those seen in North America because, in the North America, such vehicles are used for a single persons, and the roads are also quite good. In many countries, the conditions of the roads are not as good which require much more sturdier vehicles and they should carry more passengers at a time. If more people can travel in one vehicle then the traffic congestion will also be less, and the capital required to own such vehicle will also be justifiable based on the average income of individuals in those countries.

### 2.4 Vehicle Number 2

Fig. 5A shows an unique solar powered vehicle which can be powered in two ways: The first way is by using the solar energy and the second - from the regular supply of electricity. Most likely, the electricity needed can partly be supplied by converting solar rays into electricity. Here, the solar radiation is converted into electric energy using photovoltaic panels. This electrical energy is used to charge a bank of batteries. The electric motor (can be a direct current motor) derives its energy from the batteries. The electric motor provides the motion to the vehicle through a set of sprockets and chains like the vehicle mentioned above.



To charge the batteries using the solar panels, two axes, a horizontal (A - A), and a vertical (B - B) are shown in Fig. 5B. The horizontal axis is used to rotate the solar panel with respect to the vehicle, and the vertical axis B-B for parking the vehicle along any possible orientation on the horizontal plane. Such a direction can be the north - south geographical direction. One can have the solar panel inclined in such a way that sun's rays fall perpendicular to it, if one uses these two axes of rotation.

The braking is achieved using disk brakes where the pressure is applied hydraulically using master cylinders. In addition, the braking can also be applied electrically using any of the three methods. These are: (a) regenerative braking (b) plugging and (c) dynamic braking. In the last two, resistors are used to dissipate the kinetic energy into heat when the vehicle is in motion. The advantage of the regenerative concept is that a part of the kinetic energy is regenerated into electrical energy in the batteries. This would be quite useful in city driving where one has to apply brakes quite frequently. Depending upon the regenerative efficiency, the energy which is not converted into electrical energy, dissipates in the form of heat. This heat is quite valuable for electric vehicles because one can heat the batteries, if the vehicle is used in colder climates. In the plugging or dynamic braking concept, one dissipates the heat using a bank of resistors through which the current flows. The advantage of electrically applied braking is that the action is fast and there is no wear and tear of parts, as is the case in mechanical braking. controllers such as for such purposes are available commercially and were used in the present vehicle. The particular controller used was Curtis PMC DC Motor Controller, Model Number 1204X - 4209.

The batteries are stored in an insulated compartment which also stores battery chargers which convert alternating current from the regular supply of electricity. These battery chargers dissipate heat while converting the alternating current into direct current. These have transformers which get heated while functioning. Thus, even this heat can be used to heat the batteries.

The speed control of the motor, thereby of the vehicle, is done using solid state devices such as a MOSFET (the metal-oxide field effect transistors). These are used to switch on and off the battery applied voltage to the motor which was discussed earlier (Pulse Width Modulation). In this way, the available energy from the batteries is economically utilized because the energy is supplied only while this switch is on. The greater the time the switch is on, the greater will be energy supplied from the batteries and consequently, the greater will be the speed of the vehicle. These solid state devices also dissipate heat which can be used to heat the batteries in the colder climates.

The heat in the driver's cabin can be supplied by the batteries which supply the current to a resistor situated in the cabin. The second method of heating is using a heat pump which pumps the heat from the surroundings to the cabin using the electrical energy supplied from the batteries. The third method is to use semiconducting thermo-electric elements. These elements pump the heat from the surroundings into the cabin using the current from the batteries. The efficiency of the second method is generally more than the third but, the advantage of the third method is that there are no rotating parts which cause vibrations and noise. In addition, one does not use a working fluid in the third method for pumping the heat which is done in the second method. Some of these working fluids are not environmentally friendly. The heating efficiency of the first method is less than the other two.

The solar panels are mounted on the vehicle and which can be re-oriented depending upon the time of the day to face the sun in such a manner that the sun rays fall, as far as possible, perpendicular to the panels to achieve maximum conversion efficiency.

The circuit diagram for lighting used for this vehicle is shown in Fig. 6. Fig. 7 shows the circuit for charging the batteries using solar panels or from regular supply of electricity. The motor used in this vehicle had 2.5 horse power. Only one person could sit in this vehicle, and it was built and used at St. John's, Newfoundland,

Canada.

### 3. Conclusions

In this paper, two new types of electric vehicles were designed, fabricated, and tested to address the concerns of the environment, and declining fossil fuel reserves. The vehicles were safe to use, and economical to run in terms of fuel cost. They were simple to drive due to the absence of a clutch.

### 4. Acknowledgements

The author wishes to thank the NSERC Canada for providing the funds for the fabrication of the vehicle.

### 5. References

- [1] Guru, B. S., and Hiziroglu, H. R., 1988, "Electric Machinery and Transformers ", Harcourt Broce Jovanovich Publishers, Toronto, Canada
- [2] Henderson, B. and Haynes, J. H., 1993 , "Suzuki, Samurai, Sidekick, Geo Tracker - Automotive Repair Manual" Haynes North America, Inc., Nebury Park, California, U. S. A.
- [3] Hubert, C. I., 1998 "Electric Machines, Theory, Operation, Applications, Adjustment, and Control", Prentice Hall Incorporated, New Jersey, U. S. A.
- [4] Kenjo, T., 1990, "Power Electronics for the Microprocessor Age", Oxford University Press, New York, U. S. A.
- [5] Norton, R. L., 1998, "Machine Design, An Integrated Approach", Prentice Hall International, Toronto, Canada
- [6] Shigley, J. J. and Mitchell, L. D., 1983, "Mechanical Engineering Design", McGraw Hill Publishing Company, New York, U.S.A.



Copyright of West Indian Journal of Engineering is the property of University of the West Indies-Faculty of Engineering and its content may not be copied or emailed to multiple sites or posted to a listserv without the copyright holder's express written permission. However, users may print, download, or email articles for individual use.